

Appendix A.

Public Comments Received

December 7, 2022 through
June 5, 2023

Comment

I love ponies and people and parks

Why would you give in to a small group of uninformed people and close the Griffith Park Pony Rides? Where is the proof of abuse? Horses are a great way for kids to learn confidence, and responsibility. The pony rides should be allowed to stay and operate

To all those concerned,

I ask that you please reconsider the lease on the Griffith Park Pony rides. There is no abuse happening there. These are older ponies doing a job with the children of our city. They only go around with the kids on weekends and they are not forced, hit or pushed around the tracks. They look very happy walking their routine. Horses and ponies all need to walk. It's part of their digestive structure. They need to move. And what a better way than to walk around a small track with a small child. The older ponies are experienced with the kids and create a safe environment for the enrichment of the children.

Our city has a rich history with animals, including horses. Our children are not being taught the history of our nation, or the city's. Horses brought our ancestors and family members through our beautiful country.

Our younger children have no resource for education and interaction with animals other than dogs and cats. Most find pony and horse ownership a financial and locational hardship. Rental horses and ponies help these people and children enjoy this activity within a budget.

I was lucky enough to grow up with horses. My daughter was able to take horse back riding lessons at the local stables in Burbank.

Los Angeles is changing and sometimes it's not for the good. Removing the older iconic landmarks wipes away a part of the cities history. People like these activists have no real knowledge of horses, or how they can and should be treated. Mis education is the enemy here. The screaming activists know nothing about animal husbandry.

There is a never ending evil motive behind people like this. Maria Rios has been organizing several protests at the Pony ride facility, and some one has called in threats to Steve Week, the current owner of the pony ride business. This is uncalled for behavior, and it seems the city council and parks dept. are willing to cave into these people.

Have people on the city council and parks dept been getting threats too? Is this a part of the source of negativity for the pony ride lease? Does the City Council have a hand in this protester for their own interests? Maybe a parking lot? Or some other special interest group who wants that particular plot of land for something more lucrative? It's all about money. A childhood experience should never be about money. Maybe the city council members need a few weeks at an equestrian camp and take a few rides around the block. Maybe even brush and pet one of them.

The closing of the pony ride is wrong. A wrong choice for the children living in the City of Angels. I would like my grandson to know the pony rides. Just as my husband and his sister worked the pony rides in the 1970's, along side Tommy Wright. Tommy Wright who always treated his ponies properly. Tommy Wright who always stated he held a 99 year lease with the city for his business. Now the baton has been passed to Steve Week.

Please reconsider the closure and re sign the lease with Steve Week and make good the effort on the 99 year lease terms.

The woman posting hate and malicious photos, and statements about abuse at the pony ride, is using media material from other locations not affiliated in any way with the Griffith Park Pony Ride. There is NO abuse at the pony ride. These are older ponies, gently taking our children on an experience they can not get at home, or a friends house. There are no LOCAL pony rides for the city children to have an opportunity to see and interact with these types of animals.

Please sign an extended lease with Steve Week and allow the children of the city to have a positive experience about their childhood.

The forced closure of the Griffith Park Pony Rides is a loss to our community, and seems to have been carried out in a manner unfair to the concession owner. It appears to me that the Council is putting up a pretense of interest in animal welfare in order to capitulate to the threats of an interest group that - in contrast to the majority of Americans and Angelenos - believes humans and horses should not interact (see the language of their petition, implying that horses are inherently dangerous and diseased). Sure, ponies going in circles all day is not the richest animal-interaction experience for either the kids or the ponies, but how else are children without much money supposed to learn to appreciate animals, and in particular humans' connection with horses throughout history? I'd not be at all surprised to see that the zoo is next in their crosshairs - and then what will be left in Griffith Park? Golf for the wealthy, litter-strewn picnic areas and a long line for the merry-go-round for the plebes? If the city cared about animal welfare, it should have worked with the owner, or a replacement concessionaire, to improve conditions for the ponies or change the nature of the ride, with the advice of veterinarians and leaders in the equine community. Instead, it simply and suddenly shut it down. Horses are part of human history, and our connection with them can be incredibly rewarding. I'm disappointed.

The pony rides are a family tradition. We are a horse family and own a horse and have owned a pint before! trust me they want a purpose a job! They love it and thrive doing it! It's very expensive to take on more animals for anyone right now. so where do these activist get off leaving these ponies homeless. please reconsider your decision to shut this operation down. thank you

The pony rides should continue to operate as a concession. As a 4th generation Angeleno I am appalled that a small radical fringe group can close a legally operating business that was not in violation of any law. This sets a frightening precedent for small business owners in Los Angeles. Council members should not be bullied into closing businesses because a small, albeit loud group demands it. We are a nation of laws. Our elected officials should follow the laws and not cave to the demand of a small mob that is not representative of the majority of residents.

Giving into a small group of "animal rights activists" who have no actual facts on the situation is a slippery slope. Not only have the pony rides taught kids how to care for animals and become interested in horses but the horses have a job that they love. They are well cared for and retired when the time is right. Ending their lease is inhumane as most of the horses no longer have a job and may be slaughtered or other. Please reconsider continuing the lease for the pony rides. The fringe is not the masses.

This is horrible. The pony rides spark interest in young equestrians and help bring about new families into all equestrian sports as well as connecting people to animals from all walks of life. These ponies are all very well taken care of and who knows where they will go. Angelenos deserve the rides and the ponies deserve their jobs, as most horses LOVE to work. I personally own 7 horses, all of which love to work. Steve is a great guy and does not deserve this!

I fully support the continued operation of the Griffith Park Pony Rides as is. The independent report showed no evidence of abuse or poor care of these 35 or so ponies. These ponies have had training for one thing only and their job is to be ridden in the pony rides. It will be extremely difficult if not impossible to rehome these ponies in proper homes with proper care. Many are older and required medication and proper feeding. Not many are familiar with the needs of these ponies and it could lead to foundering and a painful death. The owner operator has gone to great lengths and expense to improve the environment and care of these animals and to create a great and affordable horse experience for the children.

Comment

Please do not let the children lose a valuable asset to the this community. Kids and ponies go hand in hand.

Please renew the contract!

I beg you to not cave to the terroristic demands by those pushing the radical animal rights agenda! Bullying, harassment and death threats should not be allowed or considered at all in this matter!

Thank you.

A small group of radical animal rights activists spent months appearing at the Pony Rides screaming at and harassing both the owner of the concession and the customers including small children and babies. They then undertook a campaign to shut down the pony rides with no knowledge of equines. A vet check has revealed that the ponies receive good care and there is no evidence of misuse. Nevertheless the RAP commissioners did not stand up to these people and voted to shut down the pony rides against overwhelming public support for the pony rides. This is truly a disgrace and we hope that the commissioners will take another long look at this issue and reverse their decision. They have destroyed a 75 year tradition and one wonders what else may be behind the decision.

This decision is wrong on so many levels. The Griffith Park pony rides provided an opportunity for lower income families a way to connect with ponies/horses. My children have developed a deep appreciation for equine life because of the gppr. So much so that my oldest daughter who is 14 was looking forward to hopefully working at the pony rides one day. These terrorists masking as protesters are anti-human not pro animal. They have attacked children and families and their accusations are unfounded and come with no evidence. Not to shame anyone but one of the main activists/terrorists has huge breast implants and I am guessing she's not aware how many dogs had to have those installed to make sure they were safe for her consumption. This is hypocritical and it's so unfortunate that our leaders are listening to these fringy people desperate for attention. Now the young people that work at the pony rides will be jobless, without medical benefits all right before Christmas time, the ponies will lose their jobs, and the community loses something very special. I hope you will reconsider this decision and consider the employees, as well as the children in the community whose first exposure to equine life is because of the Griffith Park pony rides.

Thank you for your consideration,

Kelli

There is no reason to stop the pony rides. This state is being destroyed from the top to the bottom. City Council leadership is full of self righteous individuals who couldn't care less in destroying everything.

May God remove every single person with all this evil agenda. I'm sick of the evil and wickedness in this nation.

RENEW GPPR CONTRACT

I would like for the space to continue to provide an opportunity for children to ride and interact with Ponies. This is vital part of the Los Angeles community as is provides an affordability for families to come to a Griffith Park and enjoy the Pony Rides with their children.

This is a great place for kids and ponies.

Please don't close it.

The pony rides were a part of Griffith Park and many a child's first experience with ponies/horses .the ponies were well cared for and had a lovely home in the Park .where will they go from there ?

Keep the pony rides open for all to enjoy. If this beloved feature of Griffith Park closes, who will provide loving homes for the ponies? The fringe group who are screaming and yelling "animal abuse?" I highly doubt it. Furthermore, NO, ZIP, ZILCH evidence of animal abuse was ever found, even after the operation was investigated. None. So, the gadflies who know NOTHING about horse- and pony-keeping will destroy 74+ years of Griffith Park pony rides? They are nothing but a bunch of provocateurs looking for victims. Thanks for ruining this wonderful feature for everyone else.

This has been a family tradition with my grandparents and now I have got to do with my three year old grandson. It's heartbreaking that I won't be able to do with my youngest grandson who is six months old and will not be able to get to enjoy the family tradition created when I was a little girl. This is TERRIBLE!!!!!!!!!!

Noooooo, this is and has always been a childhood must. Everyone in LA has special memories of their parents or grandparents taking them for the pony rides, going in circles with your heading bobbing and teeth chattering. Slower for the little ones and a little faster for the bigger kids. Fun times and then going on the train ride after or before. A day at Griffith Park would not be same without the ponies. Please leave the ponies so I can take my grandson and any future grandkids.

The pony rides are an LA treasure in the middle of a huge urban setting. It's a pretty inexpensive way to take your family to enjoy the day. Children love the ponies. I went as a child in the 50's, took my kids in the 80's, and my grandkids now. We must save this special venue.

The GPPR offer a very low cost way for children to be introduced to horses and riding. Please do not take this sweet outdoor activity away from our city. Let future generations of children experience the magic.

I would like more information regarding adopting the ponies

I started my love for horses when I was a small girl and rode the ponies at Griffith Park. I am now 64 and have owned 2 horses for the last 15 years. I learned compassion for animals back when I was a child and I know that it all started with the ponies. I visited them often with my Mom and dreamt of the day when I might have my own. It took me many years in between but my dream came true. These ponies are well taken care of and start the dreams of so many children. Please, please, please allow that to continue.

Please reinstate the Griffith Park Pony Ride concession contract.

The pony rides were an integral part of my childhood and helped forge my lifelong love of horses. There are a myriad of reasons why the pony rides should continue to operate in the same capacity for another 74 years. The pony rides are often the only opportunity for Angeleno children to touch a horse, let alone ride one. Much of the valley, and parts of greater Los Angeles have been home to some of the most iconic horses and horsemen. It's an integral part of our history and culture. As urbanization has taken over much of the county, development has pushed out horses making way for more cars and people. The cost of horse ownership has virtually doubled over the past couple of decades, space being favored for humans over animals. These animal rights activists are out of touch with what it takes to not only care for horses, but also provide them with a stimulating environment for them to live long and healthy lives. Many of these ponies are taken better care of than dogs in people's homes. They have a job, they have purpose and they thrive off the energy and joy that surrounds them when excited parents and grandparents line their children up for a ride. Many of the vets that provided third party reports are vets that I trust to call on my own horses and have accurately depicted what a great life these animals have.

I don't know what is driving the agenda to shut down this facility that's been providing a much needed outdoor experience for the greater Los Angeles community for 74 years, but it clearly doesn't consider the negative effects of shutting down this much needed recreational experience.

Please keep the pony ride. It's a vital place where our kids can experience close animal encounters and outdoor affordable fun. I've been taking my kids and grandkids there for 35 years and have never seen any problems. If there are, fix them. Don't get rid of this unique experience for our kids.

Please reconsider and keep the ponies. In reading the Vets reports it seems the ponies are being well cared for and our kids and grandkids should be able to continue to enjoy this wonderful experience. PLEASE DON'T CLOSE THE PONY RIDE.

We love the pony rides. I enjoyed them as a kid and now I get to share that with my children. We have never witnessed any cruelty. It would be devastating to stop the pony rides. Violation of the Brown Act in this decision- which needs to be reassessed. The ponies are healthy from the Cities own report. The value that the ponies bring to the lives of children is immeasurable. Please renew the pony lease! As a pediatrician, I want to represent the children. There is tremendous value of the experience to ride a pony for children. The pony rides are irreplaceable - especially for low income and special needs children. There are tremendous health benefits and can be life changing for some. Please renew the pony lease - we can work together and continue to improve the well being for children. The ponies are well loved and well taken cared of. Please do not deprive the children of LA this precious opportunity to ride ponies and experience the joy of ponies. It's priceless. I urge the City and Recs and Parks to Please renew the pony lease immediately !Pony rides - they are irreplaceable and a historical landmark. Don't mess with pony rides that a tradition for over 70 yearsPlease reinstate the pony rides ! It is irreplaceable!

Comment

Save the pony rides! Countless children including myself and my son were introduced to ponies and the horse world through the Griffith Park Pony Rides. I grew up to be an animal welfare advocate and animal rescuer with several equines in my able care. The so-called animal rights protesters that brought this kerfuffle to a boil insist that their own obligate carnivore house cats only eat vegetables. They represent the height of hypocrisy and cruelty to their own pets! They do not care about true animal welfare only about self promotion and aggrandizement. They have actually been abusing the animals on site with their loud bull horns and they are harassing young children. The pony rides introduces children to empathy for horses and other farm animals it is a uniquely LA experience with a deeply benevolent tradition. There is nothing cruel about the treatment of the animals. They are in good health and are happy and fit. Taking this vital institution away from the children of Los Angeles would be a tragedy. Taking these ponies away from their home and their careers will lead to their demise.

What towards you are. As a result of some protests by a handful of mis-informed and disingenuous animals right activists kids in LA will no longer be able to experience the thrill of riding a pony. All because of lies and misinformation. Did you hold any public hearings? Did you make a balanced and informed decision? Did you respect the long relationship with your vendor? Were they allowed to make adjustments or concessions for any problems found? You make the Grinch looks like a lightweight. Of course you could reverse your decision but I suspect you'll be too cowardly to do that too.

Having ridden the pony's as a child, and having taken my children, and now grandchildren to these facilities it has been a wonderful opportunity to introduce basic level care and consideration for these patient, older horses. A tradition which through interactivity has taught and given so much to our family. Horses need companionship and purpose as do we humans, and I have often thought that these sentient beings transmit a connection to our past that is much needed and a treasure to fully appreciate and understand how we and our forefathers connected to them in a "one on one, up close and personal" necessary part of daily life.

Please keep this tradition alive and in place where future young angelinos can benefit from the thrill and excitement of a closer relationship to animals leading to a better and more compassionate understanding of our past and future.

Thank you,

[Redacted Name]

KEEP The Ponies. They are the last affordable fun for kids. The city is hostile to kids and this underscores it. Many parks are not accessible to kids due to vagrancy. We have less park space than other big cities to begin with. We don't have Kiddie Land anymore.

Dodgers, the pier, Disneyland are very expensive. This is a sweet place to take young kids. Keep the ponies

Bring back the pony rides.

Do not let extremist win.

Steven took good care of his ponies. The pony rides is a family tradition for generations.

To Whom it May Concern:

Some of my favorite memories as a child are riding ponies at the Griffith Park Pony Rides. Going there was more fun and special than going to Disneyland for me. That's where my love of horses began and continued to grow as I eventually started taking lessons, competing in horse shows, got my own horse, became a riding instructor and horse trainer and even worked on a ranch in Colorado. I take my 2 year old daughter to the pony rides on a regular basis even though I have access to horses at the barn where I train and ride. This place is so special and so dear to my heart.

Please save the pony rides at Griffith park! The pony rides bring JOY to many families. Animals are extremely important for mental health. This is a positive experience for LA families and affordable!! The ponies are well cared for. Horses are part of our heritage and history as Californians.

Please if possible expand the pony rides to include summer camps and educational programs about these wonderful animals. Horses are so extremely healing for humans of all ages.

Please help save this wonderful establishment, the LA Griffith Park pony rides.

Thank you for your time

[Redacted Name]

[Redacted Address]

[Redacted City]

I am upset to hear that our City representatives are making a decision to remove a historical and significant part of our City. I lived in LA area for almost 72 years. My parents took me to the Griffith Park pony rides as a toddler, where my love and appreciation for ponies and horses was ignited. I have taken my children and grand children there to experience the joy of riding a pony for the first time as many Angelino family's have done for decades. The pony rides and it's location is a historical and educational experience, not to mention the excitement and pleasure it provides family members of all ages. I am asking please reconsider keeping this beloved area attraction open. Don't let this area fall into the hands of some money grabbing developer. The Griffith Park Pony Rides is part of our city's heritage and should be preserved for future generations. You have the ability to close it but you also have the ability to preserve and provide better management if that is the problem. Please reconsider.

Sincerely

[Redacted Name]

Animal husbandry education center. Kids need access to animals, especially in an urban setting. In a time of climate crisis we can not divorce ourselves from the natural world/knowing where our food and livestock come from.

I am terribly disappointed in the cities decision to close the pony rides, if you reimagine it as an educational space where children still have access to animals, that would go a long way to repairing this wrong.

Please reconsider your decision to keep this historic landmark open. I went and spoke with many parents and children and this is a very special experience for them. It took less than a minute to feel the energy and happiness of these Angelinos as they waiting in long lines with their children excited to ride a pony. The locations for inner city children to be introduced to animals and to actually ride a pony is shrinking. Griffith Park is a central location for these citizens. When will our government officials work on behalf of the people and not sell out to more development and listen to the extreme special interest groups as they continue to erase our rich history. The ponies are well cared for. I am a horse owner

Comment

As a child in the 70s I came to the pony rides and dreamed of having a horse of my own. Raising my three children in the Valley in the early 2000s I also turned to the Griffith Park Pony Rides, followed by a picnic at the park, as an affordable Sunday adventure that gave our city kids a taste of nature and communing with animals. When friends with young children came to visit from the East Coast, a stop at the Pony Rides was a necessary and thrilling part of their trip, more exciting than Disneyland! No one could imagine that a city like Los Angeles would have an amazing, huge wild park like Griffith Park at its core with pony rides to provide a farm-like experience for children.

At no time did the animals appear mistreated or overworked. Not once did we see sores or signs of lack of care. The experience of patting and then riding a pony on their own around the course gave my young children a tremendous sense of self worth.

You should not be denying the future children of Los Angeles an accessible opportunity to have an equestrian encounter because of paperwork issues or extreme animal welfare activists who are not even from this city. Children's imaginations need to be nurtured and their self confidence bolstered by a broad range of experiences and the Pony Rides are uniquely suited to this for an affordable price.

It is a travesty that you are going to close down the pony rides at Griffith Park. Contrary to the protestors' assertions, They ARE well cared for. You expected the vendor to notify you when ponies died (of natural causes) when it was NOT required. To use this as an excuse to not renew the contract is absurd. The protestors are nut jobs and you never should allow them to dictate your decision. So many children get their first horse experience through these pony rides. Where can they get them now? By having to pay \$\$\$ at a private ranch? One of my favorite photos was my little boy riding a pony at this establishment. He is now 26. By closing down the pony rides, you are denying children all over the region the ability to meet these sweet creatures and when older, perhaps becoming an equestrian, a vet, a zoologist, or all around animal lover. Please, please reconsider and allow this wonderful tradition. Thank you.

Thank you for ending the contract with Griffith Park Pony Rides! I agree with RAP that we should replace it with a non-animal attraction that is kid friendly and affordable for families. Some suggestions off the top of my head - a natural history museum to educate about local native species, a skating rink (roller in summer, ice in winter), or a Project Adventure style obstacle course. Griffith Park is a treasure and was gifted to the city as a respite for all residents. I thank you for ending the repetitive labor of the ponies and can't wait to see what you come up with.

Happy Holidays to whoever reads this! :) Thank you so much for ending the contract with the pony rides and petting zoo concessionaire! What the equestrian community isn't understanding is that there is a growing movement of people who do not wish to see animals used for profit and entertainment, no matter how well they are kept.

Mr. Weeks first posted in the local equestrian Facebook group back in February, 2022 and several times in the months that followed asking people to voice their support to RAP and city leadership at large. They failed to do so. There were several meetings where they could have addressed this issue and they did not. (I know because I called in to one of them). To claim that this decision came "out of left field" is not fair. Everyone knew what was at stake and I feel that it's an insult to city leadership to only take direct action after the decision has been made. If they felt so strongly they should have taken part in the discovery and discussion process. It's not the city's fault that they did not.

Thank you again for doing the right thing and closing down this business which makes its money on the literal backs of animals. Thank you so much for ending the pony rides in Griffith Park! Los Angeles has led the way in ceasing the exploitation of animals and I am proud that my city continues to do so.

I always hated going to that side of the park because the sight of ponies going round and round with kids strapped to their backs every day of their lives was difficult to see.

Regardless of their treatment, being exploited for profit is no life for a sentient being. Thank you for stopping it!

The Board of Supervisors voted to protect enhance and preserve and protect the equestrian lifestyle...all city departments were instructed to see what they can do to accomplish this..Press Bulletin dated Feb. 26, 2003 motion by 6th District Supervisor M. D. Antonovich..The Pony Rides are for the families and children, and have been for 74 years...This was well run by Parks and Recreation and the owner....It should continue and provide this for the children not for advocating its discontinuance.by unfounded discontent and accusations to the Parks and Recreation who did a wonderful job of providing this outlet for our children..

I am very bothered that every time a group of loud activists yells louder than another group, our elected officials give in to their demands. Please, investigate the allegations. The pony rides should not be shut down!

It is very sad that this longtime tradition is coming to an end. Pony rides are something that my kids grew up with at Griffith Park and it's unfortunate I will not be able to have my grandson experience this.

Please please don't take away the pony Rides ! I been into horse's since I was 5 Years old (61) lived in LA Tuna , moved to LVT Then bought a home in Shadow Hills Ca. I am very concerned you'll take away our love for pony's and horses. If this go's through??? I am sure the activist and the protesters believe they have a win and then they'll come after us and our horses we've been trying to fight or rights to keep our horses and these people these protesters are very mean and threatening and I was even stand it when a woman was threatening that they were gonna come after us. This is horrible thing is my concern. I can call these people Terrace and not I love her animals they have no about horses and ponies. I could understand if it were people they were very well of horses knew them very well and their sicknesses, and how they get colic. Then I could see them trying to save the horses or the ponies, but these are people that don't even have no clue about horses or ponies, and I think that's very unfair that you're listening to these people. Please save the pony rides. Thank you. I am very much a horse girl ! I had ponies as a little girl . My pony Peanuts lived to be 42 . During my growing up we also had horses too ! I still have horses. I am putting my vote in to save the pony Rides !!! Please. Scars me to hear our new Governor is for these Nasty Activists! Is this how she is going go with the activist here in the City of LA ? This means will have to fight for our Horses !!

The pony rides should remain. It may be the only exposure to riding a large animal that some of these children experience. I am in my 70s, lived in North Hollywood growing up. I have owned horses, and consider this an important venue to continue. I have already replied; but since I am 76, lived in North Hollywood my entire childhood, my first pony ride was when about 6 ponies came down my street at 5542 Auckland Ave., and for .25. cents, a lot of money, my parents would pay the man to take me and others around the block twice; of course, Auckland Ave. was dirt at the time; it had not been paved, and I fell in love with horses, rode in Griffith Park on rentals, and owned them since my parents bought me my first horse at 13 years. Still have a horse here in Shadow Hills!

Please preserve the family tradition of pony rides in Griffith Park. This is the ideal location, and the operating team in place is worthy of your support! Don't cave to developers who cynically hire protesters and peddle influence at City Hall. Do the right thing and listen to the voices of the community. Los Angeles is losing it's identity and the equestrian community is outraged at this latest, ill-considered move to shut it down.

DO NOT STOP THE PONY RIDES! This is a time-honored tradition for several generations of families in Los Angeles. Do no kow tow to small but vocal special interest groups who are using political motivation and strong arming to strip Los Angeles' cultural identity. It is absurd that you are giving in to lies about the concessionaire and small public pressure. This benefits thousands of people and is a low cost recreational facility in a city that is becoming less and less accessible to low and middle class residents. The millionaires who run PETA and other 'animal rights' groups should be shamed, not celebrated. There is nothing you're going to be able to put in place of the pony rides that will be as affordable and enjoyable. You're succumbing to gentrification of a public asset which is disgusting.

THANK YOU FOR NOT RENEWING THIS CONTRACT.

The GP ponies need to be liberated. Retired to sanctuaries where they will be loved, cherished and respected. Where they won't be expected to earn money. How about a beautiful carousel instead? A brightly painted merry go round would perfectly compliment the train ride.

Again, THANK YOU.

Comment

One of my happiest childhood memories were of my Nana taking me to the pony rides in Roger Williams Park in R.I. Now, more then ever people are not getting to experience the wonders and joys of horses.

If it's the same owners of pony rides I spoke with years ago, this operation is more then above board with their pony care. Veterinarians would agree. Horses can develop thousands of different ailments. Four may have died, but my understanding is they had 200 ponies so the odds should actually have been MUCH higher than this number of ponies passed away.

What were the AGES of these ponies?

What did they die from?

Name of veterinarian and whom they are employed by, including political preference?

I have been there many times, and the pony rides have history and should be PRESERVED as part of LA HISTORY!

Hello, thank you so much for not renewing the contract for Griffith park pony rides. I'm glad that now the cycle of suffering that occurred at that place has been put to a stop. This sends a great message to kids and future generations. It teaches us to evolve and not needlessly harm beings for entertainment nor profit. The place can be replaced with a community garden, animal-FREE models, or anything else that doesn't harm beings. Thank you! Thank you for choosing justice, kindness, and respect for innocent animals. A suggestion could be an animal free model such as something motorized or an arcade type of situation with games for kids, anything really just not animal abuse/use.

On behalf of the Hispanic community, thank you. We did not need our kids learning that exploitation is ok nor normal. Ponies should be freed just like us. Thank you for not renewing the contract.

Thank you so much to the RAP and LA city council members for choosing against renewing the Griffith Park Pony Rides contract. It was a perfect decision for a progressive city like Los Angeles. Animals have no business being used for exploitative purposes, and your decision shows that the city of Los Angeles will not tolerate coverups and secrets. please consider putting in its place other venues such as music concerts, train rides and other educational options such as an animal sanctuary where children can bond with and learn about animals. Thank you Jimmy Kim for your leadership!

First and foremost, thank you so much for deciding to close down Griffith Park and Pony Rides. The animals that are being used there are miserable from being exploited all their life. It doesn't take an equestrian expert to be able to see that.

What I would suggest as a replacement would be any of the following: an actual sanctuary where animals are not exploited/used as slaves, a ferris wheel, indoor arts and crafts center, a concert venue, a laser tag attraction, a strip club, bumper cars/go-karts, rock climbing, trampoline park, water park, an arcade, a beer garden/bar, ice skating rink, a movie theater/dive-in theater, a haunted house, an escape room, or build a few roller-coasters. Heck, just turn it into a full-on amusement park. Anything that doesn't use animals for our benefit. Thank you.

First and foremost, thank you so much for deciding to close down Griffith Park and Pony Rides. The animals that are being used there are miserable from being exploited all their life. It doesn't take an equestrian expert to be able to see that.

What I would suggest as a replacement would be any of the following: an actual sanctuary where animals are not exploited/used as slaves, a ferris wheel, indoor arts and crafts center, a concert venue, a laser tag attraction, a strip club, bumper cars/go-karts, rock climbing, trampoline park, water park, an arcade, a beer garden/bar, ice skating rink, a movie theater/dive-in theater, a haunted house, an escape room, or build a few roller-coasters. Heck, just turn it into a full-on amusement park. Anything that doesn't use animals for our benefit. Thank you.

this is a travesty. you fell victim to a crazy fanatic who was protesting and had no idea what she was talking about. you have taken the joy of hundreds of kids who may never be able to ride a horse or pony. shame on you.

Thanks for stopping those poor animals from walking in a circle all day.

Thank you for ending the Griffith park pony rides and petting zoo contract and to replace it I think something that doesn't involve animals being used some options I would like is batting cages, concert venue, rock climbing, trampoline park, water slide park, or a roller coaster.

Keep the pony rides going! There is no alternative to compare this experience to.

I strongly oppose the closing of the Pony Rides by the Parks dept. Closing the pony rides does an immense disservice to the public, especially the families. Angelenos need to have affordable access to educational and entertaining animal activities. Children love the ponies and the ponies are healthy and well-cared...the veterinarian reports support that truth. Mr. Weeks has done everything requested by the City and the vets.

I understand that there was a question of four ponies that died in the last year: one from old age (who had been retired and living out their life), 2 from colic under the care of veterinarians and one from a freak kick by a herd mate. Colic is common and every horse owners fear; it happens, as do herd accidents. These are all normal, though sad, passings. There is no reason to not renew the permit to run the concession.

I feel like you have listened to the extreme animal activists who don't believe that animals should be kept as pets. Their views are absolutely extreme and in the extreme minority. It is shameful that the Parks dept has caved to the crazies when Mr. Weeks has done everything asked of him to assure the care and safety of the ponies and the children.

I want to thank the City of Los Angeles for not renewing the Griffith Park pony ride contract. I'm glad to hear the elderly ponies will not have to circle round and round in the sweltering heat and pouring rain and that the City acknowledged key veterinary recommendations were not implemented. Going forward, I would recommend replacing the pony ride with vendors that offer art activities: watercoloring, finger painting, clay, as well as more physical attractions; such as slides and climbing structures. Thank you again.

Thank you for caring for the griffith park geriatric ponies by not re-newing the contract for pony rides. These poor babies need to be retired to caring homes or a sanctuary, and the rides can be easily replaced by other activities for children. THANK YOU.

Thank you for canceling the abusive pony rides. Let's teach our kids how treat animals by creating a sanctuary, preferably for ponies, so that we can observe and protect the animals' natural behaviors.

To the Los Angeles Department of Recreation and Parks (RAP),

I am extremely disappointed to learn of the decision to not extend the contract for pony rides at Griffith Park. My wife is a +30year active horsewoman having competed on UCLA's equestrian team, and it all started with her mother randomly taking her to Griffith Park for a pony ride one weekend when she was a small child. The claims by the pony rides' opponents are absurd. Shame on me for not learning about this issue earlier to have voiced my opinion earlier. What is next? Close the Griffith Park & Southern Railroad since it is a symbol of discrimination and oppression against the Chinese workers who built California's railroads? Close the Harding and Wilson Golf Courses since they are a symbol of elitism and waste water on non-native grasses? When will this insanity end? Shame on YOU for your shortsightedness and fear of being seen as not progressive enough.

Disgusted-

Thank you so much for making the very humane and kind decision to stop the pony rides at Griffith Park. These ponies were NOT being cared for appropriately and needed veterinary and farrier care. Many were elderly and arthritic, and were not receiving appropriate supplements to help prevent their arthritis from worsening, nor were any of these ponies receiving medication to help keep them comfortable.

Additionally, there were several instances where the pony rides put the public and children at risk. The children were belted onto the ponies, which is very dangerous, and there was more than one instance where the ponies broke free and ran across the park.

I think many adults have fond memories of pony rides from when we were children, and we want to share that same memory with our progeny. That being said, I think we also have to understand that the welfare of the animals must supersede any nostalgia. The time has come for us to realize that we can share different memories with our children.

Comment

Animal interaction is crucial when developing a child's empathy and understanding of animals. Please have the replacement venue have an animal component where children who frequented the pony rides can have the experiences they may not be afforded at home.

As the president of a ten year old local horse rescue, I could not possibly disagree more strongly with this decision. It doesn't represent the views of knowledgeable horse owners, horse professionals or animal welfare professionals like myself. Instead, it seems a tiny fringe radical animal rights group has made this happen based upon observations like a pony crying (biologically impossible - their eyes do water in the wind like ours) or ponies being outside in the rain (rain in Los Angeles where the low is 60 and you are a hairy pony, feels good!).

More troubling still, this decision seems to have been made by one person who doesn't represent the views of most Los Angelenos - at all.

I would urge you to think long and hard about the precedent being set here and why one person seems able to shut down a 75 year institution so that he doesn't have to deal with a small but noisy group of protesters anymore.

I would like to suggest a skate park to replace the current concession. Here, both children and adults can have fun and stay active using bikes, skateboards, scooters, and inline skates. Communities could form around the hobby, and traffic would be driven to the nearby train ride. Thank you for your consideration, and for helping Los Angeles move progressively forward.

Riding the pony's in Griffith park has been one of the most meaningful experiences of my daughters life. The first time she rode one of the pony's in Griffith park, her face lit up had a truly wonderful time. We frequent the pony rides regularly and it is one of her favorite things in the world. My second daughter was recently born and I am heartbroken that she will not be able to experience the same joy as my first daughter now that the pony rides are being shut down. For many people in the city, this is the only possible affordable introduction to horses. Sure, the wealthy will be fine after the pony rides are shut down, as always, because they can spend \$70 per hour on riding lessons for their children. With the pony rides however, for \$5, a child can get to ride a horse and start them down the path of love for animals, which is truly priceless.

I think the decision to shut down such a beloved feature of Griffith park, which has had such a positive effect on literally thousands and thousands of children, is a travesty and a great inequity, and should be reconsidered.

The Pony Rides are a tradition of Griffith Park that have enriched generations of children's lives. Find a way to keep them. Griffith Park is a jewel of the LA metropolis.

I think the pony rides should be replaced with a petting zoo, where kids can have animals experiences and birthday parties that are not riding dependent, but allow them to interact with / pet / feed animals. I think it's imperative that the pony rides be replaced as soon as possible, so that the park still offers an amenity and destination for low-income families.

My family & I thank you for ending the outdated & cruel pony rides. I spoke at your last meeting & suggested Funbox.com as a modern, fun activity for kids of most ages where they can play and get exercise. There's one up now at the Topanga Mall in Woodland Hills. Please check it out! Again, thank you.

Thank you so much for doing the right thing by these ponies and shutting down the rides. Growing up I loved pony rides (and horse drawn carriage rides in NYC) because I loved animals. Many wonderful memories. But I didn't understand it from the animal's perspective. The bottom line is the money. So medical records are fakes, ages lied about, etc.

Geriatric animals are used when they should be retired. Even if the business owners think they love the animals and do care for their needs on some level, they didn't care for the horses needs as their main priority. I have come to the decision that animals are not ours to be used for entertainment. I fully support the move in NYC for electric carriage rides that have vintage charm but no horses. I know families are sad to see the pony rides go but it is the right thing to do!! Thank you so much for doing the right thing.

Most domestic animals are happier, healthier & more bonded to "their people" when they have jobs - be it to guide the blind, pull the sled, compete in agility or service those who ride them. I thought the consulting vet's report thorough, professional and am appreciative it is now available to the public. It is well established that the pony rides are a longstanding and valued offering, and it is reassuring to hear that in general they have been well treated, their facilities in good order. I fear that the wish to close the facility is a loss for many families, perhaps even for some of the ponies. And it appears just now that there is a political element: local politicians who rally support by appearing to be "for the animals". I urge that veterinary exams be done on an ongoing basis, the results made public. The suggestion that an educational element be included at the facility would further round out the potentially rich experience families and young children would take away from their visit to the pony rides. Keep and improve the pony rides!

Thank you for caring about the ponies and the kids and all who witness this. I see interactive physical games for kids as something they would enjoy - like human checkers or something like that-

As the long time train ride concessionaire I am deeply disappointed by this action. Mr Weeks was a breath of fresh air compared to the former pony ride concession. For the first 25 years of my tenure in the park we received constant complaints from our customers about the pony ride conditions and the treatment of customers. After Mr. Weeks took over those complaints disappeared within a couple of months. He not only seriously improved the conditions of the animals from prior years he also did a complete make over of the concession appearance and customer service.

I am very sad for the children of Los Angeles who will not get to experience the affordable combined attraction that our train ride and the pony ride offered. Especially for our lower income citizens who get the most marginal benefit of Griffith Park parks. There is nothing else in this City that offers an hour's worth of fun for the price of the pony rides and the trains. The ponies and the trains have been neighbors and partners since 1948 and I consider it the height of folly to break us up based on the noise from a few loud voices.

Respectfully

~~XXXXXXXXXXXXXXXXXXXX~~

~~XXXXXXXXXXXXXXXXXXXX~~

~~XXXXXXXXXXXXXXXXXXXX~~

Thank you to the Department of Recreation & Parks and to Jimmy Kim for deciding not to renew the contract with Griffith Park Pony Rides & Petting Zoo. Bringing children to this establishment presents them, who are literally the future, with a behavior that is unnatural as horses do not carry their own offspring on their backs and walk around aimlessly in circles all day long within their natural environments. We must teach children empathy and respect towards all sentient beings as this will equip them with the kindness and compassion they need to be good citizens and human beings. So much can be done with the space that this business currently encompasses. For example, the space can be used as a local sanctuary within the city of L.A. which an already existing sanctuary near L.A. is interested in taking on. A playground can also be built to allow children to play safely as well as an area where sports can be practiced which will instill team work values and solidarity among children. We can work together as the united community that we are to brainstorm what this space can become. What becomes of this space will make highlight unity and beauty in the city of Los Angeles and will take a place where animals were used in the name of entertainment to one in which children observe and practice core values while partaking in quality family time.

The Department of Recreation and Parks made an extremely bad decision, unsupported by the facts when they decided to close the Pony Rides. The Department caved in to a few very loud (and conceivably well-intentioned) extremists and ignored the reports from professionals in the animal welfare industry. This is an abdication of the responsibility of the Department to look after and enhance the park experience and well being of the public. This is tyranny by a very small and extreme group that has now deprived millions of park visitors of the opportunity to learn and experience horses and animals and the Department became a complicit co-conspirator in this event. I urge the Department to reconsider and grant the concession renewal to the Pony Rides operator.

Closing the pony rides is a terrible idea. This is a Griffith Park institution and it should be maintained. If there are problems with animal care or treatment those issues should be addressed and corrected. If the concessioners can't correct the issues then the city should work with them, find out why and help them make the appropriate adjustments. Let's find solutions people. Isn't that what government is for?

It would be progressive and fun to teach families and children about growing their own food, and helping the community by implementing a community garden area, and little free libraries~ Even continuing the carriage tradition with light-up electric carriages, instead of animals, would be a fun and futuristic experience. Thank you for your consideration.

Comment

Thank you for the opportunity to weigh in on the matter of reimagining the pony ride venue that gave joy and purpose to many generations of visitors and residents of Los Angeles. A small vocal group of protestors with an urban outlook and little understanding of families, children, livestock, small business had an ability to override and influence a long standing park use. Any replacement of this space should generally not appease any small group with an urban, single issued viewpoint. The venue should be broad, unique and appealing to a broad social economic group, specifically families.

These are some ideas:

Pony rides with a larger openspace for a more free range experience.

In the past the park offered elephant and camel rides.

Nothing mechanical.

A venue with a full sensory, unique, non-urban experience with animals (smell, sound,touch).

Nothing that reflects or represents a political or urban experience.

Nothing that represents trend issues like drag shows, trannies on trampolines, evangelical crusades.

Thank you for your consideration of the ponies. We as a species really do need to consider our fellow sentient beings that we share our earth with. We need to treat them as we treat ourselves and our loved ones. It is our responsibility to care for others. Thank you once again.

Sincere gratitude for finally making the long overdue to close this outdated concession of misery and servitude for the animals.

As a long time resident of Los Angeles, since 1957, I and so many are thrilled, relieved and elated at your decision.

I envision a modern automated replacement for the concession area that would inspire and educate children, with electric or mechanical rides, and a nature learning center. Not only could this generate revenue for the City, but also be an attraction of modernization, enjoyment and education attracting families everywhere.

Again, congratulations for your courage, compassion and forward thinking in envisioning so much better for this area and our City.

Sincerely,

Thank you sooooo much for cancelling pony rides. They are cruel and exploitative

Please SAVE THE PONY RIDES in Griffith Park. As a native Angeleno I feel it is paramount to save this tradition. What is a city without its memories and its ability to support all its citizens with interesting things to do? Which in turn make the memories that we all are so fond of. The pony rides are a long tradition that gives all young children an opportunity to encounter horses that they otherwise may never have. It is often a door opening opportunity in their young lives.

I am sure that the beloved pony are well care for and that any roomers of a busy are unfounded. What do unemployed pony's do? That might become real animal abuse.

Please do the right thing here and save the pony rides. Thank you very much.

I think it is unfortunate that the Griffith Park Pony Rides will be closed prior to the end of this month. I have fond memories of being a child enjoying these pony rides. It was one of the few places in the city where a kid can be close to an animal you only see in books or pictures. Please do not take this away for other kids who have little to no access to animals near them.

I implore the City Council and Dept. Of RAP to consider the extension of contract for the Griffith Park Pony Rides. The extension symbolizes preservation of community and culture of our district, it provides a near-extinct form of recreation and therapeutic healing to a set of youth that have just endured the traumas of a pandemic, and it enriches a point of demographic connectivity across diverse populations here in LA. The robust equine community here is very heartfelt about the care and health of our local horses, no matter who the owner, and can each attest against the false accusations of any mistreatment or neglect of horses in this facility. Even if under conditions of 'evidence of no maltreatment,' we, the local Griffith Park community, respectfully ask that the Pony Ride facility remain open to the public. Thank you for your time.

It's the only low cost ride option for kids in LA and has met or exceeded all animal control and vet inspections recently contrary to animal extremist lies. Inner city kids benefit from contact with animals so much and these ponies are being well looked after. We need to keep access for low income families. You never know where the next amazing equestrian can come from. Kids need safe, ethical contact with horses and this is an excellent site to continue doing this.

Please reconsider. This is the only low cost pony ride option in LA and has met or exceeded all animal control and and vet inspections recently contrary to animal extremists lies.

I don't even know how to begin this without feeling emotional. My feelings towards what has transpire with the pony rides and petting zoo, are anger, disbelief, and extreme sadness.

To think that this experience for the children of Los Angeles, and other parts of the country even, is heartbreaking. The memories that will never be made, future equestrians now won't be molded, the giggles of thousands of children has been forever silenced. And by all the information i have read and researched, has been done unjustly and with complete malice!!

These supposed animal activists and their ludicrous ideologies have blinded all those they harassed and pressured. I'm one of hundreds of adult equestrians that credit the experience of the ponies for the love and life I now live. I work with special needs children on horseback, it has changed their life being near these magnificent spiritual beings. I couldn't imagine anything else having this effect on them, the bond is between the horse and rider, it's beautiful to see. These extreme activists are targeting all forms in the use of horses, saying the animal is not here to work for us, or be enslaved to humans. This is ridiculous thinking, and this removal of the Ponies is only the beginning to their harassment of the use of horses. You've caved in, given them the stepping stone to much larger protests against this equestrian community. And that makes me extremely angry!!

We now have the army to fight them and keep the equestrian areas intact.

You've shown us you're incapable of protecting our lifestyle, and we're not happy about it!!

I suggest you keep that in mind next time you meet and discuss anything regarding the trails, horses, or area barns!!

Upset in the last of LA's horse country -

Christina It's with great sadness I even have to write this. After what I witnessed and the people threatened and used profanity against myself and several other people. I can't believe these people bullied the city into closing the pony rides.

This establishment had years of memories behind it. It was a city landmark, people came from all over to enjoy the Ponies and pet the animals. All within the beautiful park which was close enough for children from all areas of Los Angeles.

But because of a few radicals, who lied and forced themselves onto the sidewalks of the park, frightened children, threatened parents. And insread of being punished and told to stay away, they were rewarded for their horrible acts too the citizens of Los Angeles!

I'm shocked and honestly disappointed in the city of angels, it's become a city of hell!! My heart is simply broken over this. The activists that terrified and terrorized for the last year, who some have criminal records. These people bullied their way to a victory? What does that say about the fairness and reliability of the RAP and the city of Los Angeles? It has been difficult keeping a level head through the videos obtained of these people screaming obscenities at children's trying to enjoy a birthday party, while waiting in line to take a pony ride. Threatening, intimidating and frightening children. Is this the message we want to send out to our children? Those who scream lies can take away whatever they want?? I think this is a huge mistake on the part of Jimmy Kim, who I feel needs to be removed from his position immediately. He took his position and overstepped his authority.

The pony rides are often a Young Person's first introduction to all things equine. It's what kick starts a Young Person's love for horses and therefore their desire to better the lives and health of the species. It's good for horses and it's good for people. Horses and humans also share a rare connection that isn't found with other animals. It is more than just taking away someone's opportunity to write a pony.

Please keep the pony rides operational moving forward. It's the only low cost ride option for kids in LA and has met or exceeded all animal control and vet inspections recently.

Don't price non-rich kids out of a chance to ride, and to develop an interest in equitation

Comment

I am a member of the LOS ANGELES greater equestrian community, and I own two horses. I am familiar with that Griffith Park pony rides, and I see no wrongdoing on the part of the owner or in the care of the ponies. Ponies that are stressed or allegedly looks sad, do not have their heads down. If they were agitated, their heads would be up and their ears would be perked up. The ponies appear to be walking along quietly. The operator, Steve weeks is a very experienced horse professional with many years of service to the LOS ANGELES community. The Griffith Park pony rides is a wonderful experience for hundreds of thousands of children of all backgrounds in Los Angeles, and provides them the opportunity to be up close to a large animal, and to potentially become horse owner, or a rider as they get older. equestrian activities in our community include horse trainers that facilitate therapeutic riding programs for returning veterans of war with PTSD, and for children with mental and physical disabilities, it includes the equestrian teams of our universities, including UCLA and USC, it includes the equestrian program for young veterinarians at Pierce College. There are so many incredible programs in our community that all have a beginning point of a young person experiencing horses for the very first time at the Griffith park pony rides. My own family has been there many times. As such, I strongly urge you to listen to our experienced horse community, for our assessments of the well-being of our beloved ponies, and for our expert opinions on the pony rides and how it could be actually expanded as an even more accessible and wonderful resource for our whole community. Instead of shutting it down, I am voting for expanding it, and finding ways to include more community members, so that they can benefit from having the beautiful experience of being around these incredible animals, that we all love and cherish.

Often pony rides is the first place children have the opportunity to be on a large animal.

Some people can't afford to get their children ridding lessons, so for those kids that love pony's this might be the only experience they are able to have!

I have 5 kids and that was their first experience ridding a pony.

This experience spurred on my children's love of horses and pony's.

Please keep the Pony rides and the smiling faces of the children that get to enjoy this experience!

Introducing kids to animals at a young age teaches them care, empathy, and helps build better social skills. The pony rides are a big deal developmentally for kids and it's not right or fair that only higher income families have access to them. Which, WITHOUT the pony rides at Griffith Park (the only real low-cost and accessible option), is exactly what would happen. So many kids would miss out on a fundamental part of growing up in this world — interacting with the earth, with the animals, and gaining a perspective beyond the urban day-to-day? It's too important.

And as for the ponies, themselves, let's turn to the opinions of the vets and animal control professionals, not the ill-informed.

Care and empathy for them is the point, it's what children develop from being around them, learning how to treat them, learning not to scare them... These animals deserve care and empathy and they get it! Plus, the next generation learns how to give it.

Losing sight of that and getting rid of the pony rides altogether would be a great travesty.

Comment

My passion for horses started at age 5 when my father took me to a pony ride. I loved it so much I began drawing horses and writing stories about horses, which led to a career in art. A lifetime of owning and loving horses has been the greatest joy of my life. I'm a Glendale resident, but LAEC and the Rancho Equestrian neighborhood has been my home away from home for over 30 years.

For the sake of justice, you must right this wrong and renew the contract for the pony rides. It's time to finally stand up to the extremists who have weaponized misinformation and unfairly targeted Steve Weeks and his business.

Please understand that when you or your colleagues closed the iconic pony rides that have served Los Angeles for 74 years, many people will interpret that decision as wrong, immoral, corrupt and possibly illegal. It was clearly influenced by the radical extremists that no one in their right mind should take seriously.

We are in what I call "The Golden Age of Misinformation." The founder of the Los Angeles Alliance for Animals (LAAA) is a master of misinformation. The group has 667 members. Very few of their members are based in Los Angeles, or CA. Their mission is to shut down ALL the pony rides in the US. They consider ALL equestrian sports "slavery." Additionally, they regularly protest the treatment of ONE of three elephants at the LA Zoo. What's so special about that elephant? He's the only elephant that belongs to the LA Zoo. The two females are on loan from other zoos.

These willfully blind bullies need attention like fish need water. They're not working to stop real horse abuse, such as horse slaughter, starvation, abusive training methods used on Tennessee Walking Horses, Mustang roundups, horse racing deaths, etc. Instead, they have a vendetta against one man. The ONLY reason they have targeted Steve Weeks is because he's easy prey – his business is dependent on a concession with the city of Los Angeles. They're like a coyote chasing a Chihuahua.

Like election deniers and QAnon, their belief systems are completely divorced from reality. Their strategies are underhanded, aggressive and illegal. They have been repeatedly caught on camera shouting obscenities at parents and children. They camped out at the homes of city officials and left death threats for Steve Weeks, resulting in 11 arrests.

On May 25, 2022, the motion to renew the Pony Rides contract was approved.

LAAA put out a call to action to telephone Los Angeles Councilman Jimmy Lee. Consequently, interim Parks General Manager Jimmy Kim was quoted by NBC News criticizing Steve Weeks for lack of transparency. That's highly ironic because it's Jimmy Kim who lacks transparency.

No public hearing was held, and every single hearing was canceled. The motion to cancel the contract does not show a vote by the City Council. The letter sent to Steve Weeks on November 23rd, terminating the contract was illegal and violated the Brown act.

Jimmy Kim's decision to shut down the pony rides blames the victim. It sets a bad precedent and empowers a small cult of radical extremists. Their false claims do not represent the views of the majority of the Los Angeles community. They spread misinformation worldwide on Facebook and other social media platforms. The fact that their petition has 82K signatures is misleading – ONLY 1,839 are local residents.

The Save the Pony Rides petition has gotten nearly 6K LOCAL signatures in a short period of time.

LAAA claims of equine abuse are extreme distortions of a fact, and/or blatant lies.

EXAMPLE: The following is posted the LAAA Facebook page, "4 Geriatric ponies dead under Steven Weeks watch. Attorney General Rob Bonta should investigate Steve Weeks for animal cruelty."

THE TRUTH: It's true that four geriatric ponies died.

THE LIE: The deaths were not as a result of animal cruelty.

All the ponies that passed away were retired and no longer working. That's because Steve Weeks gave each and every one of his ponies a forever home. Very few horses and ponies are that lucky.

One pony died at the age of 38! That's the equine equivalent of 120 years!

To claim that the pony died of animal abuse is like saying "120 year old man dead. Attorney General Rob Bonta should investigate his family for abuse."

It's RARE for a horse to live past the age of 30. My horse lived to be 32. He outlived all the other horses in DEF Barns at LAEC. Trust me, no pony lives to be 38 unless he/she is well cared for and loved. It's proof that Steve Weeks takes excellent care of his ponies.

Two other retired ponies suffered severe colic and were rushed to the hospital. The vet recommended euthanasia. Typically, Colic surgery can cost around 10K to 30K. Again, the fact that Mr. Weeks took the ponies to the hospital indicates he takes good care of the ponies. Sadly, Colic is the most common ways horses die. It can happen at any time, to any horse. The fourth pony was kicked by another pony; it was a freak accident.

I'm convinced that Los Angeles City Officials are guilty of spreading disinformation. Claims that the contract was canceled because Steve Weeks didn't notify the city is impossible to believe. It was not required by the contract. Compare and contrast the minor contract violations by Steve Weeks vs. the major contract violations by frequent violator and influential developer Tim Behunin. Compare and contrast RAP's treatment of Steve Weeks vs. Tim Behunin.

The ONLY reason the pony ride contract was terminated is because city officials didn't have the guts to stand up for Steve Weeks, the ponies, the majority of their constituents, the equestrian community, and the countless children that will be deprived of the magical and potentially life changing experience of riding a pony!

PLEASE REVERSE THIS TERRIBLE DECISION.

It concerns me that Animal Exhibits are once again under attack by animal rights groups, who are using paid actors to simulate grass roots objections to these Community Services. Paying actors to harass the Pony Ride patrons, and city council is an illegal form of Political Astroturfing, and should be subject to investigation by the FTC. I strongly urge the Council to look into the genesis of the 'protesters', before moving forward with any decisions that remove or ban Animal Exhibits in Los Angeles. Not only would be be a grave loss to the children and families of Los Angeles if the pony ride were discontinued, it would also set a terrible precedent for all other businesses and services in Los Angeles that have anything to do with animals. The Los Angeles Zoo participates in important conservation work, with 120 Species Survival Plans. An important part of that work, the Animal Ambassadors, would be threatened by any ban on 'training' of animals. Children learn compassion for other species by having ready access to non-humans. Putting Animal Exhibits at risk of closing, can have far reaching consequences. We need our children to know and love animals, so that they have the proper appreciation of the diversity of life. Please choose wisely.

Please keep the pony rides. It is the only low cost pony ride for children in Los Angeles!

Comment

The pony rides In Griffith Park has been one of my favorite memories as a kid growing up. My parents would bring me every weekend for my pony ride. It started a love for horses & now at 64 yrs old I have a small ranch in Simi Valley that I just love because I have my horse & all my critters here. My son grew up loving horses & it helped him thru the difficult years. Please keep the pony rides...kids need the feel of an amazing creature under them

I am writing to express my opinion that The Griffith Park Pony Ride remain operational. It is the only low cost ride option for kids in LA. It has also met and exceeded all animal control and vet inspections. I feel that the pony ride is an important recreational and educational activitie that needs to remain in our community. Thank you.

Thank you so much for canceling those cruel pony rides! Hopefully they can now enjoy their lives. Thank you for your compassionate decision.

Since time immemorial, humans and animals have been a team! People need to interact with animals, and in the case of domestic animals, they were bred to work and interact with us. Urban children in particular need exposure to live animals, and horses and ponies in particular. This form of entertainment is also affordable.

Let's do what we can to keep these interactions going, safe, affordable, kind, and respectful. Thanks!

In favor of keeping the pony rides operational in Griffith Park!

The Griffith Park Pony Rides are an invaluable experience to many Angelenos. Many a local vet, horse trainer, farrier, artist and horse advocate fell in love with horses and ponies there. It is a place of horse and human connection that is sadly dwindling in today's world. It is real. It is fundamental to have positive experiences with animals as both social and psychological development. It is healthy.

It is healthy for the ponies too. For horse owners and advocates, we actually understand the management needs and concerns of a pony herd. Please listen to us. Please listen to those voices with horse and equestrian professional and regular horse owner experience. It is not easy to manage a herd and Steve Weeks has done a tremendous job both before the attention and after in addressing the details of Dr. Rachel Sachar.

As an example of lack of understanding, the opposing group actually lists a WOLF SANCTUARY as a place of retirement or placement for the ponies! Their understanding and plan for after care if the pony rides close is just beyond insane and not humane. It is quite misguided.

Please listen and heed and note where the letters -both in support of and anti - are coming from. Please remember you represent LOS ANGELES AND LOS ANGELES COUNTY. I am a resident of Burbank and my own horses have boarded at LAEC for over 20 years. I am an equestrian professional who works in many barns in Southern California. Please listen to local equestrians who know horses. We would be the first to report neglect and abuse - and we just don't see it with the Griffith Park Pony Rides, Steve Weeks, the employees and most of all, the ponies.

Please reconsider the decision and bring back the concession as is. Steve Weeks has a permit issued by Animal Control through May 2023. If the governing body of animal welfare and safety finds them in compliance, RAP should too.

Thank you for your consideration-

Jodi Heaston

California native and horse person since my first ride at GPPR

These pony rides have been named on 100's of things to do in LA and many of them in the top 10 things to do with family. We are lacking affordable things to do in LA as the cost of everything goes up and it's always nice for those effected most being able to go out and enjoy the park in such a Unique opportunity. It's unfortunate to see so many protesters that are not native they do not hold our values and they do not speak for the Southern California LA people and our love for the pony rides. I have worked at the LA County fair for the last 10 years and I continue to see more and more and more attractions involving animals being removed completely due to protesters I really hope that the city does not choose to give into these terrorists and allow them to have any weight in the decision being made regarding the pony rides.As for the terms of the lease I am not sure what the agreement was regarding the passing of any animals on the property however considering the age of these ponies I would not hold Steve wicks accountable for the passing of these animals considering the body condition and health condition of all of the other animals on site. It is not uncommon for horses to be perfectly healthy and fine one day call licking and down the next day and I do believe that Steve wicks made the right choice in the care and treatment of these animals since day one.My family or I will never attend another attraction at that site we will not go to the train rides any longer we will not go to the LA zoo and longer we will not spend any money on city owned attractions moving forward if The parks department caves to the terrorists wall allowing the bridge home to be in the park that also poses a very very large safety threat to the community the public and the children in that park I would definitely say the world is upside down! I really wonder how many of the drug using residence of Griffith Park (bridge home) we're out there riding ponies spending time with her family..... I am sure the number is few. Do not take away an investment that the city of Los Angeles has made for the last 73 years to the children of Los Angeles we have enough problems going on with this generation we do not need to be known as the one to destroy traditions and take take take until there is nothing left Please keep the pony rides it's an asset to our city and had been listed on several top 10 things to do in LA with kids list/blogs. It's so unique and something that everyone can afford... getting ride of the pony rides would mean the next price point for something like this would be \$50 and only for kids 8 and over. When I was a kid I know I would of never had that experience that shaped so much of my Character if it wasn't for the Affordability of the pony rides. I look back and it was such a great time with my family being all together for some time in the park. I have 26 years of experience caring for horses and 24 years of horse rescue experience. I have completed the "world's toughest horse race," the 100-mile Tevis Cup. I have ridden 1,635 miles and counting in American Endurance Riding Conference recognized competitions. At various times in my life, I have been responsible for the care of every kind of equine, from miniature horses to draft horses. I have assisted in humane seizures of neglected equines, and I have personally behaviorally rehabilitated horses deemed dangerous. I use positive reinforcement training methods and science-guided management practices with all horses under my care.

Based on my extensive experience with equines and the most recent veterinary report on the Pony Rides, I believe the Griffith Park ponies are exceptionally well cared-for and there is absolutely no reason to destroy the livelihood of a caring owner and business operator over the nonsensical shrieking of activists with zero equine care experience. The pretext given for not renewing the pony rides' lease was that four ponies' deaths in their retirement facility were not reported on time, even though the city contract does not require the pony ride operator to report deaths of retired sanctuary animals. To suggest that the deaths of four geriatric animals from ordinary causes during their retirement is evidence of "neglect" is like declaring everyone with dead grandparents an elder abuser. Ponies do not live forever, and colic is the number one cause of death in all domestic equines regardless of management protocols.

Furthermore, I want to comment on the overall idea promoted by the animal extermination extremists that horseback riding is "slavery" inherently harmful to equines. Not only is this scientifically proven to be false—horses' parasympathetic nervous systems are positively regulated in a calming manner by contact with a familiar human—it is a ridiculous misunderstanding of domestication. There are no true wild horses in the world except for the Przewalski's Horse, an endangered species not used for riding. There are certainly no wild ponies! Domestic ponies are the equivalent of domestic dogs, a species incapable of thriving in the wild that has been selectively bred for a certain task for thousands of years. Just like Border Collies want to herd sheep, domestic horses want to interact with humans and want to exercise in collaboration with humans. It is very UNHEALTHY to keep a confined domestic equine and not provide it with exercise, such as riding. Equines denied sufficient exercise often develop pathological behaviors such as cribbing, weaving, and self-mutilation.

Ultimately, this whole situation is proof that decisions about equines should be made by equine experts. I understand it is difficult for those without equine experience to know when they are being misinformed by malicious actors like these extremist protesters. I sympathize—I wouldn't know how to regulate, say, a particle collider! But this is why RAP needs to make all equine related decisions through extensive consultation with the equestrian community, not by bending to pressure from the loudest mob.

Comment

Keep the pony rides for the kids and the ponies! I have owned ponies and horses for over 30 years. These ponies are not overused or abused. They are doted on by their care givers and are living really their best life. Horses and ponies evolved alongside humans for both species benefit. Horses and ponies live longer, healthier lives when with people and getting plenty of exercise. Ponies require less nutrient dense food than horses and can easily become overweight. They were designed to move all day looking for food. They are extremely susceptible to insulin resistant (IR) diseases similar to diabetes. They are also susceptible to arthritis. These ponies having a job and walking, trotting is much better for them to keep IR and arthritis controlled than living in a dirt lot field where they are not encouraged to exercise and get fed two to three times a day. You can not put a pony in a lush green grass pasture as they will literally eat themselves sick or to death. Most ponies love little kids. Ponies are very smart and can be quite difficult for adults to get them to do something they don't want to do but they will happily do what kids want them to do. Also keep in mind horses and ponies were designed to live in a herd and become very bonded to their family. Separating them is very stressful and cruel. Thank you for your time.

I am writing in favor of keeping the pony rides operational. It's one of the only low cost ride option for kids in LA and has met or exceeded all animal control and vet inspections. I have worked for a company that uses pony rides for parties and events and kids and parents alike love them. The animals are very well cared for and showered with tons of love and affection.

This is one of the best animal ride providers in LA! It's one of the only affordable options I found. My daughter adored meeting Milo, and is already eager to meet tinkerbell. Would be an absolute shame not to offer this service anymore. I already have friends interested in coming out next year. The ponies here are so sweet, always clean, and the Staff is always friendly. This has been an annual experience for my family for the last 3 years. I can't imagine how badly my daughter would freak out if she knew this was about to close. She's named all the ponies herself. We have a friend who's interested in trying next year as well. She is willing to come up from Oregon for the chance for her daughter and mine to ride together. It would be a shame for this to end I have no idea what we'd do next summer.

I am in favor of keeping the Griffith Park Pony Rides open and available to the public.

I'm a 61 years old woman. I have been a horse partner for almost 20 years. I call myself a horse "partner" instead of an "owner" because my horse isn't someone who can be "owned". She is a huge part of my life and has been extremely healing for me. My relationship with her is one of the most important relationships in my life. I love her and I know she loves me.

Denying the introduction to this sort of relationship to others who can't afford to take care of their own horse is tragic. Please do not take this away from people who want to know these amazing beings.

As a child and young adult I experienced horrible physical and sexual trauma. My relationship with these wonderful equis spirits saved my life. I had horrible depression and dissociation prior to working with horses. They helped me learn about myself and helped me find my true spirit. I don't know where I would be without them.

I now train other people how to work with their horses in a compassionate and loving manner which helps them build a strong and heartfelt relationship. These animals are naturally healing for us, and we for them.

Without access to these magical animals, other people, children and adults, who experienced trauma like mine would not have the opportunity to heal in the way these spirits help us heal. We are partners on these journeys of healing.

There is a mountain of evidence that equine assisted therapy helps heal all sorts of trauma; it helps bring out the essence of children who have emotional and developmental disabilities, it helps people who have substance abuse issues overcome their underlying problems that keep them using, it helps women and children find their voice and power after domestic abuse, etc.

Please don't take this away from the people who need this type of healing. Please keep the Griffith Park Pony Rides open to the public.

Good Afternoon,

I have been ask to write to you on behalf of the Southern California Horse Show Association(of which I am on the Board) in order to show our support for the pony rides remaining in operation. To not have this iconic establishment in Griffith Park would be a terrible loss to Angelenos and all.

SCHSA is a very well respected local horse show association. We have existed for over 40 years. Our mission is to educate, facilitate personal growth and promote high standards of horsemanship. Horses are our lives. Horses are what has made us who we are. We are kind. We are hardworking. We are sensitive. We are patient. We are happy.

To not have the pony rides available to the children and the community would be taking away an immeasurable source of joy and the possibility of having that one ride on that four legged treasure become a moment that changes a life forever. That may sound exaggerated but our members and the many other people I have spoken to about this closure can acutely remember having their lives changed by a horse(some from the very pony ride we are trying to save).

To care for horses is to be self-less. We are custodians of their well being. Steve Weeks has been shamed by social media influencers, targeted by gig-working protestors and seen what he has devoted so much to to torn to shreds.

Please take more time to consider this matter.

This letter is not intended to glorify Weeks, it is meant to glorify the magical and marvelous ponies that the community so adores and appreciates. To not have them continue to enrich the lives of so many, in ways that are beyond articulation would be ever so sad. Mr. Griffith who gave Los Angeles the Park with a capital P would surely agree.

Thank you for your time,
██████████

I think the closure of the pony rides is highly detrimental to the community and it's residents. The access to affordable equine interactions is a special and unique feature of this location. Young children learn a particular kind of empathy through interactions with large mammals like this, and for residents kept from experience on horseback, through either location or financial problems, the Griffith Park Pony Rides provide an accessible option to experience it. Beyond this, the pony rides are a historic feature of the park! As a lifelong member of the Los Angeles community, I can't remember a time the long rides weren't there. I urge the department to consider rethinking the decision to close the feature permanently. Perhaps after some renovations of the space, the pony rides can return in their rightful place there.

Comment

As the Director of The Children's Ranch Foundation, a therapeutic animal caretaking program in the Atwater Village Equestrian District, I join other business owners, equestrians and residents of the City of Los Angeles in urging you to act immediately to halt the pending eviction of the Griffith Park Pony Rides.

At The Children's Ranch, we teach kids, adolescents and adults with learning, social/emotional and developmental challenges how to care for horses. There is a delicate balance that must be found in both helping our students learn important life skills, and caring for the needs of our horses. We are careful to always prioritize the health and well-being of the equines we care for, while still teaching our students important life and independence skills.

I feel confident that the Griffith Park Pony Ride concession holder, Steve Weeks, could similarly prioritize the health and wellbeing of the ponies in his program, while still offering this unique chance for children to interact with a pony in the middle of the city. For many Los Angeles kids, the Griffith Park Pony ride is the only low-cost opportunity they will ever have to interact with a horse (a sensitive prey animal). I am also confident that Mr. Weeks can address any concerns that animal rights activists have, and respond to all recommended policy changes made by the third-party equine expert.

Closing the pony ride so suddenly puts the ponies at grave risk. It is extremely difficult to re-home ponies in the middle of the city, especially over the holidays, and with no notice.

Instead, my hope is that a compromise can be found – one that honors the needs of the ponies, and also preserves the Griffith Park Pony Ride for future generations of children.

Thank you for considering,
[REDACTED]

I've worked with horses as a child and teenager alongside my grandpa. I've worked with children as an adult as parties where pony rides and horse rides were present. And the one thing I consistently have seen is the love of the owners and caretakers towards these animals. Not only do they make sure their health is excellent, but their and the kids safety as well is great. I believe pony rides are a beautiful way to introduce children to these gentle giants and taking them away would be devastating. These create lifelong memories, and growing up around them at my grandpas house made me love and appreciate all the love and care that goes into them to keep them happy and safe

I am in favor of keeping the pony rides operational. I think it is wonderful to have a low cost ride option for kids in LA.

PLEASE DO NOT CLOSE THE GRIFFITH PARK PONY RIDES!!!!

The pony rides are one of the only activity left where children, especially low income children, can interact with ponies and nature, instead of looking at them on an ipad!!!!

Getting rid of the pony rides is a terrible idea. I understand the intention would be to protect animals, but the animals are treated very well and animal therapy is very needed for the children. Children heal and learn so much by being close to the animals and riding the ponies. Taking that away is further severing nature from people. Now more than ever we need to incorporate nature and allow ourselves and our children to heal with the help of animals. Keep the pony rides!! Thank you.

My belief is to retain the Griffith Park Pony Ride as representation of the Park's historic past. It helps to have and maintain a tangible experience. I also would like to see the venue design to be more attractive and less dusty. This is because there are equestrian planners within the urban region, not to mention California State Polytechnic University, Pomona and San Luis Obispo.

To terminate this attraction is to beg the question of its replacement. I hope that it is part of the Griffith Park Master Plan.

Thank You for your time and attention.

Please do not cancel the Griffith Park pony rides, this is a valuable service that is provided to the public and it provides many benefits to citizens of the state who come to visit and bring their children. Please renew the contract so this service can continue to be utilized.

Please consider an educational access point for children with ponies. Experiences where children are taught how to brush a pony. & maybe ride while lead on a lead line by a caregiver. Petting zoo /educational access with pony rides in a new format. Please don't give up on the ponies- it's the only affordable access for all children in Los Angeles How on earth did this happen? The ponies are well cared for, vet approved, and many enjoy their retirement onsite creating a forever home. There is absolutely no abuse other than that of the extremists who show up and disturb the peace and verbally assault parents and children as they go to experience their first encounter with animals. I myself am afraid to go to the pony rides or bring my daughter because of the shouting and abuse by the activists. It sends a shiver of fear down my spine to expose myself to it let alone bring my child to be assaulted by them just to see the ponies. How can you let them 'win'? Where is the protection for families who want to attend but are fearful of attack by crazies? Why haven't you protected your own concessionaire? What you have just done is ripped away the ONLY opportunity in this city for young children and families from low incomes to experience horses. Without this early introduction to animals and their care an entire generation will be deprived of this access. Ask Mr. Weeks to add an educational component so that people understand ponies body language to understand why they behave the way they do, but please please please don't throw away the only access point to horses to poorer families like mine. I beg you, I love horses and ponies and want little children from all over Los Angeles to be able to see them. Please reverse your decision so that access to horses isn't only for rich white people.

Thank you to everyone that made this happen! Animals are not products and they should not be brought into this world for the sole purpose to be used as commodities. Thank you!

The Griffith Park Pony Rides has been unfairly attacked by radical animal activists, most of whom are imported from outside of LA to take part in their disgusting demonstrations, and who know nothing about horse care or ponies. The Parks Commission must not knuckle under to these "outside agitators" who want to eventually outlaw any kind of animal ownership or activity. The pony rides is a well-run operation that has provided enjoyment to generations of Angelenos, and should be continued.

Firstly, I'd like to express my deep gratitude for RAP's wise decision to not renew the contract at Griffith Park Pony Rides and Petting Zoo, where animals exploited like vehicles and petting toys have been enduring immense stress for decades. It's about time the progressive city of LA transform this cruel, antiquated concession into a NON-ANIMAL MODEL, as there's a major shift worldwide away from using animals for food, fashion, entertainment, and other anthropocentric uses. Here are few ideas:

◇ The only acceptable animal model would be a sanctuary.

Kindred Spirits Care Farm, Chatsworth, is hoping to move closer into the city, and this would be a great replacement to allow truly healthy and respectful interactions between animals and children. The operator of the sanctuary has wonderful educational programs for children, including children's arts and crafts corner.

◇ Children today lack a lot of physical activity, and the following sports activities may also help fight a high child obesity rate in the U.S.:
Tennis, squash, badminton, volleyball, basketball courts, rock-climbing, trampoline park, skating park, yoga at the park

◇ Giant board games: chess & checker boards, jenga, connect four, etc

◇ Children's playground, ground fountains, giant floor pianos, outdoor concert area, ferris wheel, mini rollercoaster, Go-Kart, small-scale botanical gardens, science park, library

◇ A plant-based/vegan cafe with ample outdoor seating for parents to relax in while they await their kids, giving the Parisian afternoon stroll-at-the-park atmosphere. A wonderful inspiration would be the very Coffee and Plants vegan cafe in Pasadena owned by the talented singer Leona Lewis.

There are so many other great ways this area of Griffith Park can be transformed into without exploiting animals. Thank you all once again for listening to the concerns of not only Angelenos, but citizens worldwide.

Please continue the pony rides as an option for children who visit the park

Comment

The Griffith Park Pony Rides is a treasured and historic destination that locals have been taking their children and children's children to for decades. The ponies are well cared for, and certainly well loved by both staff and clientele. I am saddened for this community's loss, especially for the children from low income families who love horses and animals yet have no other way to connect with these special, healing animals. Activities with horses, especially in Los Angeles, are increasingly expensive and as a result exclusionary of those less fortunate. It's sad to think of the kids who were probably looking forward to seeing the ponies over their holiday break. The disservice LA Recreation and Parks is doing for such families implies to me that this department does not in fact exist to improve access to recreational activities, nor quality of life for everyone in the community for the better.

I feel this City of Los Angeles and RAP are making a grievous mistake in shutting down the Griffith Park Pony Rides. To make a decision that affects families and children without consulting the same people it affects is taking away the voice of the Los Angeles citizens and giving it to a few Animal Activists that don't even live in this community. I am strongly opposed to letting tyrants with an agenda, to dictate how to live our lives. Shame on these Public Offices capitulating to these terrorists. If you see the videos of how they terrorize parents with children or people who don't agree with them, you cannot help but call them for what they truly are. Terrorists!

Canceling the pony ride concession should be reversed. It was done based on false information. The ponies were found to be well cared for and in satisfactory condition by vet assessment twice in the last year. By the councils one statement the operator was not obligated to notify the board of deaths of any of the ponies and per vet report no deaths were due to neglect.

The allegations of abuse are unfounded and come from people who are unfamiliar with equines and have no understanding of equine needs and normal behaviors. The board has an obligation to run the city for the majority not for the vocal few. The cancelling of the pony ride contract was done without citizen input and was based on inaccurate assumptions.

I am dismayed by the abrupt closing of the Pony Rides at Griffith Park. Further, the process did not appear to consider the input of the public.

My family have been horse owners for many years and understand the joy and learning from these animals. In my opinion, there were never any serious problems that were not addressed by the operator. It appears "outsiders" have taken it upon themselves to dictate what is for the good of our citizens; further, they seem to think these ponies should not die from colic or old age.

Please examine your process and reconsider!

Please elaborate on the process and decision making of not continuing the contract for Mr. Weeks pony rides in Griffith Park. This is a valuable service and enhancement of the community. I would like the Los Angeles parks and recs dept leadership to reconsider their decision.

Thank you ,

If the ponies have met or exceeded safety regulations and veterinary recommendations, and the ponies do not show any signs of duress or mistreatment, then the pony rides should continue as an experience for families. It appears that the pony rides meet those expectations and I support keeping the attraction open.

To let a noisy few destroy an institution in LA over 2 items that were quickly repaired is criminal. The ponies are well taken care of and well trained by a quality horseman and his caring staff. Don't let this tradition be destroyed by some ulterior financial motive.

Thank you, [redacted]

Resident of LA

Those ponies are a much needed contribution to the families and children of Los Angeles. They are well cared for and are satisfied in how they are treated and asked to work. Why close down a source of such joy and togetherness in LA? What joy and happiness the Griffith Park Pony Rides have brought to the families and children of Los Angeles. The ponies were healthy, well taken care of, and humanely treated in their jobs. Nothing, nothing can replace them.

Pony rides are a world wide reality but shut down here in Los Angeles. Why deny our children that joy??? The heart of the matter is can animals have a job that benefits human beings. I believe the answer is YES. But the necessity is that there be knowledgeable oversight to maintain a healthy, safe, humane work situation for the animals involved. I know horses. They most certainly tell you if they don't want to do something. They pin their ears. They snake their head back and nip at you. They raise their hind leg threateningly. And there are many other behaviors available to them to communicate displeasure. I watched those ponies, and I saw none of those telltale behaviors. I saw well fed, well groomed, well behaved ponies doing their jobs.

I also saw happy, excited children there with their parents getting ready to do something outside with nature away from digital devices.

Our world needs that and pony rides are a world wide phenomenon. We must, we must keep that beautiful facility for the families of Lis Angeles.

Yours,

[redacted]

The ponies are well cared for and appropriately housed. The protesters are not horse people and have unrealistic ideas of what equines need to thrive. The ponies are able to socialize and enjoy outdoor time as they are meant to. I'm a lifelong horse person and have always approached the rides with a critical eye, but I find that the ponies are clean, healthy looking, and seem cheerful about their jobs. They have a nice life with their herd.

As an Equestrian who spent many years learning natural horsemanship and equine body language, I feel I should share what I know so that non equestrians might see a glimpse of what we see.

Horses are prey animals. Unlike cats and dogs, our more common predatory companions who may lash out aggressively for reasons beyond fear, true aggression in a horse is almost always the result of neglect or trauma. It's a reaction born out of fear, self preservation, and a lack of trust.

While most people are more familiar with dogs and cats, Horse body language is vastly different from them, and cannot be equated. Horse ears act as little flags on the top of their heads that show much of what is going on in their heads. Relaxed forward or slightly back ears are signs of safety. They say the horse trusts their surroundings and feels comfortable enough to not be on guard or insecure. All of the horses and ponies at the Griffith Park Pony Rides show these exact body language cues. They all feel safe, happy and content.

Another marker of a happy horse is it's behavior. A calm, relaxed horse or pony is a happy horse or pony. Level headed, a phrase we use frequently to refer to people, originated with equestrians in regards to calm horses due to the level way they hold their head when relaxed. A level headed horse is calm and composed, exactly what it means today when speaking about another person.

As for concerns about life span, wild Mustangs only have a life expectancy of 15 years. That said, horses and ponies can live much longer than that in captivity with excellent care, which is exactly what they receive from Steve. Every horse and pony in his care are in excellent body condition and look incredibly healthy.

Now think about what \$5 gets you. Maybe 2 bottles of water? A bag of chips and a soda? A piece of pizza? The cost of a pony ride that Steve is offering is that amount. He is offering an experience to a populous that doesn't often have access to ponies, much less the tack (saddle, saddle pad, halter, brushes, etc) to be able to safely ride them.

Can you think of something that you did when you were younger that cost that much? Maybe it was swimming in a lake, or getting an ice cream on a hot summer day? Experiencing snow for the first time or going to a petting zoo... Do you remember the warmth you felt? It's those sorts of memories we remember as we get older. Please don't steal away such a staple for selfish or falsely informed reasons.

Having a toddler thru COVID when our children had nothing to do, when the park and pony rides finally opened up, I took my son and it was one of the happiest memories coming out of a very dark period. I feel like there are little affordable outdoor activities to spend as a family and our children would be losing an important activity if the pony rides shut down. I feel the pony rides and the petting zoo helped make our Griffith park special. I pray the city can find a way to retain this valuable service to our community.

Comment

Support the ponies. Given room to roam, Ada what's food and care. Access for the children too!

I believe the contract for pony rides in Griffith Park should be renewed. The ponies have passed all independent vet checks and the reason given for ending the contract makes no sense. The ponies whose deaths were not reported were NOT part of the working group. Instead, being too old to safely work, they were maintained by the pony ride operator so they could enjoy a safe retirement. NO requirement for the reporting of pony deaths was in the contract. The ponies provide affordable and invaluable access to living creatures for people of modest means. Small children will happily stand in line for an hour for the three times around the arena ride. The look of delight on their faces cannot be compared with anything else...it is sheer joy! The pride of the parents who are able to provide an affordable treat for their children is also important. NO public input was sought before this decision was made by the RAP General Manager who did not visit the pony rides and who did not contact the Los Angeles Equine Advisory Committee, appointed by the Los Angeles City Council to address such issues. There is no need to explore other options for this space; the experience provided to children is excellent. The pony ride operator has spent significant amounts of his own money to insure the ponies are well cared for. This attraction is a part of Los Angeles history and service to children which is essential.

I urge you to preserve this important attraction which provides an outstanding experience for the children of Los Angeles and work for ponies who might otherwise fall into unsafe hands. This is a win-win!! Please do not miss this opportunity.

I'd like to thank you so much for making the humane decision to end the pony rides. The ponies, the public, and I are very grateful. I would like to see a non-animal form of family entertainment replace the pony rides. We all know that when money is involved, the welfare of animals is not a concern of the business. I am also concerned about where the ponies will go. I would like to see them go to a reputable sanctuary. It is important that they retire somewhere where they can enjoy the rest of their lives. Thank you. Thank you. Thank you. You're the best!

Please do not shutdown the pony rides. There is family history there for so many folks. My mother rode them and now my children ride them. These ponies are well cared for and bring so much joy to Los Angeles. And they're affordable. Please don't take this away.

Hi my name is Terry Saucier, I am a 25-year horse-owner writing to ask the Department of Rec & Parks to reconsider and to keep the Griffith Park Pony Rides and Petting Zoo open. The Pony rides at Griffith Park provide children of all income levels the rare opportunity to meet and ride a pony at an affordable price; horseback riding is out of reach for many. The horses and ponies at Steve Week's facility are in excellent condition, well fed, cared for, hoofs regularly trimmed, and they receive regular vet care - as verified in the 2 reports by the independent Veterinarian hired by Rec & Parks. The LA Equestrian Advisory Committee and others with 100s of years of combined horse care experience have sent letters and expressed support for this facility. By ignoring these facts, and choosing to "listen" to the loudest uninformed protesters who are making unfounded claims, using misleading flyers to attract protesters, and bullhorns to shout obscenities at parents and their children that riding is slavery... is not the answer. One has to wonder why this decision was made behind closed-doors without public comment. This lack of transparency and the effort to misrepresent the reason for closing the facility is suspect. If a couple of LA City Councilmembers and Rec and Parks decided they no longer wanted Griffith Park to provide pony rides; then they should have honestly accepted responsibility for this decision and worked with the concessionary to provide plenty of notice so that it could be closed down or re-located in an orderly fashion over an agreed period of time. Instead, the staff are abruptly losing their jobs before the holidays, and these 50+ beautiful ponies are being ripped from their herd and kicked out on the street with less than 3-weeks' notice - this is in itself inhumane and abusive. The horses and the children of LA deserve better.

The closure of the Griffith Park Pony Rides and the proposed carving away of other equestrian activities is a very slippery slope. The Los Angeles Alliance for Animals (LAAA), the group you've now conceded to, does not believe any horse should be ridden. Does this mean the LAPD Mounted Unit will be cancelled? Does this mean the Mounted Park Rangers will be shut down? Do we need to forgo hosting the 2028 Olympics since there are equestrian events? Do we ban horses from the Rose Parade? Does USC need to find a new mascot? Where does RAP and the City draw a line?

I write to you as a lifelong Angeleno who grew up, and my parents still live, in Los Feliz. I am aware of your involvement with the closure of the Griffith Park Pony Rides and it is very disheartening. We should appoint people who speak for our community... not those who bend to an extremist organization run by a woman who has multiple arrests on her record (including domestic violence against her own family including a restraining order against her from THIS October) and lives hours away in San Diego County.

I grew up riding the ponies in Griffith Park - that was my very first exposure to horses. As a child I then attended Summer horse camp at TES in the Los Angeles Equestrian Center. I begged my parents for regular riding lessons and to have a horse, but they could not afford it. They could, however, afford the low price of a ticket at the pony rides. My parents continually told me I could have a horse when I was able to afford it myself. Today, I am 33 and own two of my own horses in the Glendale/Burbank Rancho. I spend over \$20,000/year at local, small businesses for my horse care and more and more it's feeling like I need to take that money to another city.

Dr. Rachael Sachar - who you all hired to report on the GPPR - is MY PERSONAL EQUINE VET who takes WONDERFUL care of my two horses. I trust her opinion inherently, she is honest and does not sugar coat things. Dr. Rachael expressed to me in person this Fall, while doing dental work on my horse, that the ponies are fine - they are well taken care of. I've read her full report on the facility and it shows that, as well. Out of 33 ponies in work - NONE show signs of lameness. Given most are over 20 years old, that is actually an indicator of how well these horses are cared for. Each of the health items called out in the report are typical regular maintenance items common with horses. Teeth needing floating, some sand in the gut needing clearing, small abrasions. None of the horses requiring further treatment were in work. As well, failure to report the four pony deaths to the city is not an adequate reason to cancel Mr. Week's contract since his contract NEVER stipulated he had to report deaths.

Horses have been domesticated and ridden for OVER 5,000 years. They are hardwired to crave work. If I ONLY let my horses run around in the arena and do not ride them which engages their brains, they end up with pent up energy and turn that into destructive behavior. Think about Border Collies, Australian Shepherds and Heelers - without work, these animals are unhappy. It is similar with horses.

Instead of going after a facility that is already providing a comfortable forever home for 34 healthy ponies (many of which are geriatric) - animal rights activists should be going after direct ship businesses in other states (Bastrop LA Ship Pen, Bowie TX Kill Pen, Stroud OK Kill Pen, Kaufman TX Kill Pen, Lone Star TX Kill Pen). Where horses are shipped out of the country to Canada and Mexico for consumption. Horses are expensive, ponies are expensive - especially so with the steeply rising price of hay and feed. Rehoming 34 ponies means some will slip through the cracks - especially the geriatric ones with health maintenance needs (such as Cushings) - and wind up in the auction/kill pen cycle. They may have adopters lined up now, but I don't trust none of them won't end up at auction down the road.

Honestly, this whole thing feels like a land grab in which RAP did not go through the proper channels. No public comment was allowed prior to the contract not being renewed by Mr. Kim. Our LOCAL petition has over 5,800 signature in only ONE WEEK. Zohra Fahim's petition has been up for over a year and only has 1,800 LOCAL supporters. The 82,000 number is misleading as the MASS of those signing are NOT from Los Angeles. Shouldn't you be listening to the voices of the people who put you in your positions?? I'm sure you all already had something in mind to put at the location prior to cancelling Mr. Week's contract. Allowing public comment now on what should go there is just covering your asses after already mishandling this.

I am just so, so disappointed.

Please keep the ponies. There is evidence that the protestors against the rides were paid and accusations about the animals false.

Keep the ponies in Griffith Park. They ARE well cared for. This is ridiculous

Comment

Please keep the Pony's they bring special memories and a joyous memory for all. They ALL look healthy and very well cared for.

Keep it open, I'm an equestrian who rides in Griffith park and just across the river in Atwater. As someone who knows and loves horses, it appears these ponies are happy and well cared for. The introduction and education through experience they provide to city kids who would otherwise never be exposed to livestock/amazing animals at a young is invaluable.

Keep it open, I live near the park and always drive by and see a huge line of kids and families in front of the pony rides. It's such a good use of the space and the introduction and education through experience they provide to city kids who would otherwise never be exposed to livestock/amazing animals at a young age is invaluable.

Please do not shut down the pony rides! Keep the current set up and employees, change the manager/owner if you need to. This is the type of place that makes Griffith park and LA unique. Everytime I'm there I see families from all backgrounds and income levels enjoying horses. It's affordable and easy to get to. It supports the love of horses as was the initial donation for the land. I am a horse owner in Griffith park for 10 years now and mom / patron of the pony rides. With a

Discerning eye I've watched to make sure there was no animal abuse. There's none! The tack is well fitted, they are groomed, they love as a

Herd, facilities are clean, and the horses show signs of comfort and happiness with their ears and body language. It might look like they are sad to a non-horse person but it's actually the opposite. I also think it's super shady how you are coming to this conclusion. One person makes this decision?

Please save the Griffith Park pony rides. Griffith Park provided me with my introduction to ponies and horses as a young girl. This ignited a spark that has burned within me for over 50 years and while I have never owned a horse, I still make an effort to seek out opportunities to ride. The experiences as a young child riding the ponies, having birthday parties, and going to Travel Towne with my family fostered a life-long love and appreciation for Griffith Park and the City of Los Angeles.

Beyond my personal experience, the pony rides provide access to interaction with domesticated farm animals that many children growing up in Los Angeles may not otherwise ever have exposure to. This type of experience is so enriching and a special escape from the intensity of life in an urban environment.

I urge you to re-consider the termination of the pony rides. The operator appears to be responsible, and the ponies appear to be well cared for. It is a special part of all that Griffith Park has to offer. Rather than completely ending it, perhaps there are some measures that the City can put in place to provide Angelenos and animal rights advocates with the assurances they need to recognize that the animals are being treated and cared for appropriately.

I grew up in the Elysian Valley with 9 of my siblings and enjoyed our trips to the Griffith Park pool , train and mostly the pony rides. Where I recently brought my grandkids after the Pandemic to enjoy my childhood stepping stones. One of my grandkids flew down from New York to enjoy these moments with me. I ask not to close this fun place down. Since this is a Therapy place & kids that have special needs enjoy such a historic place. Those against this should be concentrating on how to protest against homelessness and help that cause rather than messing with our kids recreational activities. I recently visited the ponies and they had the ponies drinking water and waited for half hour as the staff was respecting the animals break time. I even have a video and pictures. So I'm asking TO PLEASE DONT CLOSE THIS MAGICAL PLACE FOR NOT ONLY LOW INCOME AND UNDER SERVED COMMUNITIES BUT TO ALL CHILDREN THAT DESERVE A PLACE TO ENJOY CONNECTING WITH ANIMALS. NOT EVERYONE CAN AFFORD DISNEY OR AMUSEMENT PARKS.

Thank you for taking the time to read these responses. I feel compelled to voice my opinion this pony park and it's inhabitants should be allowed to continue. The animals have been treated well as the past inspections prove. PLEASE do not allow this small group of extremists to dictate terms and destroy this treasured landmark of this city. Lastly, as a concession for the animals involved, perhaps a limited work schedule on hotter days could be an option. It's worth noting again that the recent death of these latest ponies were likely age related and that they were RETIRED! Thanks once again for the time and best of luck with the decision.

Comment

I am a horse lover and horse owner. No one wants to see ponies suffer but these protestors are not horse people! They don't know how to read a horse's behavior. People who don't know equine care tend to anthropomorphize them in human terms. "Oh their head is hanging down they must be sad." No they are resting and calm and content. These ponies are lucky. They are well fed and catered for. Their feet are trimmed. They get to exercise everyday with easy walking and trotting carrying little children. They are older because an older horse is a safer horse for children. They are checked for health by vets I den. Their teeth are taken care of so they can eat well. If they need medicines, they get them. I am almost 70. I went there as a child. My children also rode the ponies and now my grandchildren! Before Steve Weeks took over 6 years ago, I did notice that the ponies needed some attention-some of their feet needed trimming. Steve has done a fine job. He has horse trainers to train the ponies. His workers seem to love the ponies and of course, the children love to ride them. I am a filmmaker and I was there a week ago to see for myself. These are important because this is often a child's first chance to be on a pony and feel the joy of petting them and being close to them. I know for me it certainly began a lifelong love of horses. Horses are intuitive and empathic. They take care of the little ones. Horses are used for therapy in many programs. They develop bonds with people and healing can happen. You can talk to a horse and feel better. These ponies have a job. It's so much healthier for them to be useful. In the wild they would be eaten. It's about respect. We house them and feed them and take care of them and in return they give joy! Please don't take this away from children. They need real interaction with animals in a safe place. As long as the animals are loved and taken care of, that's what I care about. I live in shadow hills in an equestrian community. We all don't want to see this precious resource for all families shut down! I talked to a trainer who talked to a young protestor who said she knew nothing about horses but that she told to show up and yell to the parents and kids and she would be paid \$25 an hour! If the pony rides get shut down, what's next? Rental stables, horse shows, even an individual horse owner. Is it abuse to ride a horse? The fact that they trust us to be in their backs is a big deal. Horses are prey animals. They are food for lions! You develop trust and it's a very rewarding experience. There are many therapeutic riding places - to help veterans suffering from PTSD to paraplegics who when walking on a horse whose stride mimics the way humans walk helps their bodies and their minds heal. If a horse is unhappy, its ears will go back. There's a saying in horsemanship - it's never the horse- always the rider If's horse bucks, they are trying to tell you something. The saddle hurts it something isn't right. I haven't seen any pony acting up. They like doing what they do! Thank you. Please keep the pony rides open and available to the public!

I would like to see the pony rides continue to remain operational. This has always been a great activity for children, and a true asset for Griffith Park.

The Griffith Park Pony Rides needs to stay at GP but become a 2.0 version, just like the LA Zoo upgraded to a 2.0. After 74 years, it deserves an upgrade. In addition to a permanent shade cover, interactive educational elements for ages 3 to 7 about ponies, colors, breed, what they eat where they are globally could be easily incorporated. Most of all the birthday party areas can be made more private with vegetation screens to block any protesters on bullhorn making little kids cry.

Having access to GPPR is also a social economic divide issue. If you are a rich 4 years old, your parents will be able to put you into lessons at \$75 to ride an old pony on a lunge line. You can see how many inner city kids and families come for \$5 to have a ride.

I'm absolutely broken hearted about the loss of the pony rides. It feels like a death. You may consider it a rebirth, but it's not a rebirth if children cannot touch feel, smell, ride and look at animals. We all have a jobs to feed, cloth and care for ourselves. These ponies are only doing the same thing. They're providing a service for food a nice place to stay and friends to hang around. I hope I never see one of those ponies at the slaughterhouse. I don't think the young people who are fighting for the rights of the ponies understand. And I'm not sure how to help them understand when you're young you're idealistic. As one matures, and take up more leadership. We learn the long term consequences of our actions. Let this leadership body support the pony rides because you all know once they are gone. I forgot to say: children will protect what they love. They will destroy what they have no relationship with. This will have a great impact on our world in the future as they grow into leadership positions. The boy was about 8 years old asked for his favorite pony and then he road it at least 5 times around and around. He had an expression of pure joy. He built a relationship with the heart of that pony.

The pony was relaxed we know because her head was down. She walked around the track without a child on her back because there were no children available and because this is her identity and her purpose. She saw children come to the line and she moved into place to receive them.

The worker a young beautiful girl said: " these ponies are very well taken care of and I love working with them. If there was something wrong here I would be the first to report it." I am a horse owner. I went and spent 3 hours several days down there to check on these ponies and they are being treated very well. I would bring my own pony down here knowing that she would get loved, cared for, and exercised daily.

Please please please renew the contract for the pony rides. It is awful that yet another thing for low-income families is being taken away. These ponies are treated with so much care and it makes me so sad that my daughter will not be able to experience this as well as our future kids. This is such a gem of Griffith park and is so unique. I love how much there is to do in Griffith and that there are things for low income families. Please please don't take away these pony rides

I think you should reconsider your decision and let the ponies stay. For many young Angelenos this is their first, and only, way to experience riding a real pony. Work WITH the pony people FOR THE BENEFIT OF ALL CHILDREN IN LIS ANGELES!!! Thank you!

In 1965, my parents took me to the pony rides in Griffith Park for the first time! I loved it, and so it became a regular thing as well as the carousel and mini train rides! I remember vividly my favorite pony was named Pepper! There was nowhere else like it, and to this day, it's remained the same. You can't go anywhere like that place! Awesome memories for you and your kids! Fast forward to 2004 when I first took my daughter there to ride the ponies. I stepped to the window and told the older lady at the ticket window about my childhood coming there since 1965 and about Pepper. To my utter astonishment, (and I must admit I'm writing this thru lots of tears) she told me it was HER that sold me my pony tickets way back then, and she fondly remembered Pepper, and how good of a pony he was! I looked at my wife, and I couldn't help but cry!! It was SO special to me! I mean, what are the chances of THAT?! Like 50 years ago!!! My mind was blown! Point is, for generations, we have been able to enjoy ourselves, then OUR children there! It's a total wholesome atmosphere, and those owners always have cared and taken great care of those ponies to the nth degree! The thought of this going away is a Los Angeles travesty, a most terrible thought!! PLEASE don't let the political correctness destroy something that is SO universally loved away!! I BEG YOU!!! It's an institution here!

Thank you for listening....

~~Non~~native Californian. I've lived here my whole life!

I implore you to please renew the city contract for the Pony Rides in Griffith Park. I know the Task Force meeting is this morning, but the animal activists are wrong so please don't succumb to their lies. There have been no violations recorded against Steve Weeks and the treatment of his ponies, and if you've ever seen the joy on children's faces when they ride his ponies, you'd know this is a lifetime event they will never forget. Please reconsider renewal! Thank you, Sue

The pony rides at Griffith Park are a part of Los Angeles history and have been a huge part of my family's life. I cannot imagine Griffith park without the rides, which give many children who would never have access to horses a chance to ride one for the first time! The horses are loved and treated well.

The pony ride has been a mainstay of Griffith Park for many years now, bringing joy to many children. To replace it with something else, because of an arrogant and ignorant activist, is a disservice to the community at large. I think the concession should be reinstated, by another pony ride contractor, if the current one has dissolved his contract. All the facilities are in place, thus saving the taxpayers additional funds for "new entertainment".

I am writing in favor of keeping the pony rides at Griffith Park operational. This is a unique and popular activity that enables kids to be around and interact with large animals, in particular horses. It is also the only low-cost horse riding option for kids in LA. The current pony ride has met or exceeded all animal control and vet inspections. Please renew this on-going park tradition.

Comment

The Griffith Park Pony Rides are not only a staple of Los Angeles, but a necessity for the health and well-being of its residents. While it is tempting to rest on the laurels of the attraction's longevity – over 7 decades – providing entertainment for generations of Angelinos, what remains unsaid amidst the false accusations of animal cruelty and unsupported claims of neglect, is the large, positive, impact that the long-standing animal interactions specifically have on Los Angeles' minority groups.

Los Angeles contains neighborhoods disproportionately affected by poverty, which encompasses a lack of/limited access to healthcare, mental health resources, education, let alone pony rides. With horseback-riding starting at \$50-\$125 in LA, the \$5 pony rides at Griffith Park are the most affordable way for families of any background to experience horseback-riding for the first time. With LA County's poverty rate being 26% higher than any other county in California (Los Angeles County Department of Public Health; January 2013), \$5 pony rides are one of the cheapest sports that provide physical exercise while also supporting the reduction of economic inequality.

According to the previously cited "How Social and Economic Factors Affect Health" document, a healthy LA County depends on assuring that everyone in every community has a healthy start to life, through childhood development programs and opportunities for social engagement. In terms of childhood physical health, the Griffith Park Pony Rides offer the benefits of improved cardiovascular health, core strength, calorie-burning, the lowering of blood pressure, aiding decision-making, and enabling relaxation. When the U.S. spends more than twice the average of other industrialized countries on healthcare – 18.3% of the GDP in 2021, as stated in the Centers for Medicare & Medicaid Services' "National Health Expenditure Data" Fact Sheet – the \$5 pony rides offer a very low-cost alternative.

Parent.com recently released an article noting that, "teens who had contact with horses had lower afternoon cortisol levels and lower total cortisol concentration per waking hour at the study's end compared to the teens on the waitlist. The results suggest that regular contact with horses may help reduce stress levels and promote healthy outcomes for teens [131 teens participated in the study, with 53 teens randomly allocated to the 11-week horse activity program and 60 teens placed on a waitlist to act as the control group]" (ParentCo., September 20, 2022). Lower cortisol levels translate to a reduction in stress and anxiety in the body.

It is not merely the mental well-being of children and teens affected; specifically, the Latinx community – LA's largest population – is being inadvertently targeted with this call for closure decision. The National Alliance on Mental Illness (NAMI) touches on the community's "Barriers To Mental Health Care": Hispanic/Latinx communities show similar vulnerability to mental illness as the general population, but they face disparities in both access to and quality of treatment. More than half of Hispanic young adults ages 18-25 with serious mental illness may not receive treatment. This inequality puts these communities at a higher risk for more severe and persistent forms of mental health conditions, because without treatment, mental health conditions often worsen.

35.1% of Hispanic/Latinx adults with mental illness receive treatment each year compared to the U.S. average of 46.2%. This is due to many unique barriers to care. Plainly put, closing the rides disproportionately hurts Mexican-American workers as almost all are of Latinx/Mexican heritage. Mexican-American comprise a large amount of pony riders. This is likely due to the intrinsic connection between their cultural heritage and equines. A Whittier Daily News article updated in 2017 illustrated how horses are a cultural link for Mexican immigrants: "For some, owning and riding horses is so imbedded in their culture that they do everything they can to maintain a sense of country living in the concrete world of Los Angeles County."

Many workers like [Carlos] Fernandez [52] living in Los Angeles County...earn low to average wages [to] squirrel away their money in order to own a horse. That's because riding and being a charro, or Mexican cowboy, is part of the pride and heritage they bring to America. [...] For people of humble beginnings from ranches in Mexico, being able to ride a horse and teach their American-born children how to properly ride is a matter of pride. Even 200 vaqueros were seen riding through the streets of Compton on September 20, 2020. A Frontiers in Public Health article published in 2017 explained how "Horseback Riding Improves the Ability to Cause the Appropriate Action (Go Reaction) and the Appropriate Self-control (No-Go Reaction) in Children":

There are many obvious health benefits to riding, including developing a strong core and legs, but there are also many less obvious benefits, such as increased confidence and introspection. Few studies have addressed the effects of horseback riding on children and the mechanisms underlying how riding affects humans. We examined the effects of horseback riding on the ability to distinguish Go/No-go tasks and solve arithmetic problems in children.

The result: "Riding on a half-breed horse or a pony improved the ability to perform Go/No-go tasks and solve arithmetic problems, possibly through sympathetic activity." This is important because "self-control has been shown to be one of the most robust correlates of a wide variety of measures of crime, deviance, and violent behavior" (Cambridge University Press, 30 July 2018). Citing all these reputable sources and recent studies further indicates that the closure of the pony rides will only do the community more harm than good. By having a known place for children to learn self-control at an affordable price in the community, the City of LA may be preventing juveniles from entering the "school-to-prison pipeline".

Regarding more harm than good, what originated the call for closure was the concern for Griffith Park's treatment of their animals. A readily available report by Dr. Rachael Ostrom Sachar (of the Twin Oaks Equine Veterinary Services) written on December 8, 2021 and subsequent progress report filed in April 4, 2022, illustrate that while changes need to be made in order to improve working animal conditions – specifically pertaining to climate change-affected aspects of their care/surroundings – the ponies are in healthy condition. Any suggestions made have been acknowledged and are in the process of changing for the better.

Ultimately, at the tail-end of a pandemic that wrecked small businesses at great cost to the city's revenue and morale, taking away one source of merriment for children craving distraction and normalcy is cruel in and of itself. What ought to be proposed instead is developing a timeline for Griffith Park to further improve the condition of the Pony Rides, rather than pull the rug from underneath them altogether. With so many issues plaguing LA City Council meetings, let this be one aspect they need not worry about on their docket.

The pony rides are essential to Griffith Park. They provide thousands of children the experience of petting and riding a horse that may never get an opportunity to do so. The majority of children that come to enjoy the ponies are lower income families that wouldn't be able to afford otherwise. The pony rides are beloved by thousands and many generations and you are willing to throw that away for a handful of crazy people that have no experience with horses. I was there the other day and spoke with a few and of the protestors and they admitted to having absolutely no equine education and very limited experience of being around horses. But they felt the horses looked unhappy. I have read the vet report from your vet and she stated the ponies and that they all met state required health. Steve has implemented every item that has been requested of him. So lets stop lying and tell us the truth behind the shut down.

I have been told you want the equestrian community input but yet you did not even go to your advisory committee before making this decision. Nor did you come to the horse community to ask for our input. Worse yet you didn't go to the people that use the pony rides the most, the kids and their families.

You can close Steve down but we will not stop fighting to have the pony rides back. It is time for you to stand up against the bullies and do what is right for the kids and the community REINSTATE the pony rides and give Steve the contract.

These ponies are our friends. They've been with us, members of the community, since many of us were small, when the world was simple, and good things were easy to discern. Sharing enrichment with the ponies, and our loved ones, in nature is good, but to displace these living beings to lesser spaces is clearly wrong, it's harmful. The hurt will resonate in all involved, but especially in those who have the power to make a better choice. To sleep blissfully at night, protect the good in these animal's lives, protect the warmth and love they have and deserve until only nature says it's time. Thank you, friend. Until we meet again.

Its so unjustified to close the pony rides (a 74 year Los Angeles tradition) because of some loud, foul mouthed protesters who know nothing about horse behavior. My first experience with horses began at the pony rides and now at 67 years old, horses are a passion my life. Please don't let this Los Angeles tradition be stolen from future generations.

Comment

I'd like to begin with thanking Jimmy Kim for shutting down the Griffith Park pony rides. I have a few suggestions from my kids ages 8 & 11. Marina (age 11) would like to see outdoor painting class, knitting and crocheting class, pottery class with kiln. Micah (age 8) would like to see an archery class, building/making things out of used items, and making things out of wood. We would NOT like to see the pony rides replaced with another activity involving animals. If the city feels that kids and families should have access to animals that we normally wouldn't come in contact with on a daily basis. I would suggest an animal sanctuary where families can go and learn how to take care of and respect animals, but this should not be turned into some sort of petting zoo. My family, and I thank you for your time and considering our input.

The four ponies that died were senior/retired horses, at least one of whom was 38 years old. Horses rarely live past 25. Horses that aren't cared for will definitely not live that long. The others I hear died of colic which is very common with domesticated horses. The whole equestrian community in Glendale/Burbank stands with the Griffith Park Pony Rides.

I personally brought my children here when they were small and would hate to see it go, especially with what I now know.

From what I have heard, none of leases for the Griffith Park Pony Rides required reporting horse deaths and to use that as a reason to close the venue seems unfair. The whole Recreation and Parks Committee is not in favor of closing this venue and yet they are being disregarded as are the thousands of people who have come forward in favor of the pony rides. Please please listen to the people and not the fanatics who know nothing about horses.

Please reconsider this. These horses are well cared for & treated respectfully n humanely. This is a cherished family activity in GP that should not go away any time soon. Please hear your public & keep the ponies!

I strongly feel that the Griffith Park Pony Rides and petting zoo remain open for a number of reasons. I have read the extensive documentation (PDFs, inspection reports etc) on your website and it seems like Mr Weeks, the concession owner was in FULL compliance, and the only thing he was remiss on was timely notification of the sale or death of a number of horses. The veterinary reports show no current issues - Any issues pointed out were fixed.

HOWEVER, nowhere does it say that Mr Weeks was given ANY sort of explicit information with a timeline to do such notifications OR the given the opportunity to fix the issue - so it feels like he is having his long time business closed due to the park not being clear about its desire for notification. It seems like you are finding a technicality: he was not told to do this with timeline at any point in the past.

This concession has been open for 74 years and so many animals have died over that time - you know: natural process of things, and this has not been an issue up to now - Why now and why terminate a lease without giving Mr Weeks any chance to rectify this situation? Especially considering that it was not brought up by the park as an issue in the past. It feels like the park has an agenda to close this and has found an excuse to do so.

ALSO: The petting zoo WITH NO VIOLATIONS is also being swept up in this and closing even though it has NO violations.

I recommend they continue operations but have your needs for notification be made in a clear way in writing. I - and many many others - would hate to see such a lovely experience for families (many low income and many who rarely if ever get to see live animals) that has been a part of the Griffith Park experience for so long.

EVERY CHILD, regardless of their financial situation, should have access to this experience! Also, the animals benefit as well The people need their park, the people need the pony rides and the people need their petting zoo - They need to connect in reality and not on a screen with this vital cultural resource.

Please give them the opportunity to fix their errors and continue! The families of Los Angeles need this to continue!

Please reconsider keeping this business open. I am a veterinarian and have worked in the horse industry as well since I was a small child and had my own ponies. Horses and ponies, in general, need basic things to be happy and feel loved....safety, shelter, food and water, and human touch and interaction in this domesticated world they now live in. This notion, that animal rights extremists are suggesting, that all animals should be "free" is essentially a death sentence to domesticated animals in the world today. Bottomline, horses and ponies are expensive to care for and they are animals that need to move and essentially, even in normal free ranging circumstances, they need to work to forage for their own food and shelter. Their "work" to give children pony rides offers many benefits to themselves as well as the human benefits of interacting with the ponies.

The ponies that are commonly aging and may be sent to meat market or euthanized otherwise are given care and love, food and water, shelter, etc in exchange for some walking and little trotting while carrying a small child. The movement and brushing, handling and general care is good for the ponies well-being and we literally could write an entire book on the benefits that the human-horse bond has on children and adults alike.

Perhaps rather than closing down the business completely, the city should agree to evaluate and monitor the care of the ponies with an individual qualified to do so. Place some rules and restrictions on the business such as no pony rides when > 98 degrees or each pony not to be out working for > certain number of rides or hours each day. Have a veterinarian evaluate soundness, fitness of ponies to perform their minimal duties...maybe put age restriction on their duties such as those > 20- 22 years of age just become part of pony petting population. Maybe suggest business has animal handling classes so these children, living in a city, have some opportunities to learn about animals and how to care for them and they can charge a small fee for those classes to help cover the ponies expenses, etc.

Animals are costly to care for but having a light duty "job" is both good for them physically and mentally and gives them a way to live out their lives amongst other pony friends too. They are herd animals. I think this business is extremely beneficial for ponies and humans alike especially within the confines of a city....just find a few ways to ensure they are receiving proper care and parameters to abide by to ensure their well being is always considered within normal standards of animal care. Stop cow towing and listening to a few extremist and loud radical voices suggesting that the ponies should be given "freedom". These extreme groups are literally creating a death sentence for these animals while they ignorantly think they are protecting them because they have no understanding what the animals really need for a healthy and happy life. The business has many elderly animals and retired ponies. The fact that some have passed away...it's called LIFE, at some point we will all die and hopefully it is amongst our friends as it happens with these ponies.

Please reconsider your closure of such a beneficial business for the lives of the ponies and the children too. There must be some law that would stop extremists from harassing this business owner -- the protestors behavior that I've seen on video is what can lead to accidents and mental distress of the ponies and the children too. Stop the extremists behavior...not a respected business that has existed for > 42 years. If animal well being is truly a consideration...than this action is unjustified.

Thank you for your consideration of my comments.

Sincerely,

[Redacted Signature]

**PS...I'd be happy to volunteer my time and expertise to the city to evaluate this business and their practices more closely and come up with ideas to help them run it successfully for the future with animal health and well being at the forefront of creating those parameters.

Thank you.

Keep the pony rides. They are a Los Angeles institution.

Comment

Especially during the holiday season, it's important to think about all members of our community because animals just are like us. They love their families and, as they get old and retire, having the stability of a good, safe, place to be with their tribe gives them comfort and love in their old age. We know that ponies are extraordinarily social animals.

For over 70 years The Griffith Park Pony Rides has accepted ponies from all races and walks of life. They have been a sanctuary, and, more notably, a home. And as of my last memory they have over 30 - some of which have been there with their pony family for decades.

Christmas is a hard time for local horse people and other environments that would have the ability to take these animals in. If a pony is sent to the North or the Midwest it can die of the weather or suffer frostbite, not having a furry enough coat grown for that climate. If it is sent to a new owner it can suffer from unintended neglect. If it's sent to a sanctuary run by so-called animal rights or welfare groups then it can legally be killed without recourse when it no longer makes a suitable sob story profit for the location.

It is exceptionally cruel to rip these animals from their families, to send them away from their comfortable home to an unfamiliar place, to separate them in a state of hysteria and duress, where, like elders forgotten, they have neither family, joy, occupation, or the security of home. Make no mistake, ponies scream, sometimes for weeks, when they are taken from their herd. It causes real pain and suffering to them, sometimes leading to death.

All of us animal lovers know that there is a proper way of transitioning children and animals into a kind and loving environment. We know that this is also a hard season to do that so I implore you to think about the actual comfort and care of these animals. To consider their emotional needs before abruptly tearing them from their Griffith Park home at a time that will create greater abuse, confusion, and a burden on the equestrian networks that could otherwise take them in.

I do hope that you will see some wisdom in a gentle transition and a deeper inquiry into their welfare and help them to do what is best for these animals.

I strongly support keeping the pony rides concession at Griffith Park in its current location. I believe Steve Weeks has done an excellent job based on his compassionate care of the ponies including many elderly ponies who have life long "retirement" plans even after they are not longer able to be ridden. How nice it would be if most elderly people had the same attention, medical care and comfort in their golden years as his ponies do! Steve's years of service to the city bringing children joy and connection to nature and his quick attention to any and all concerns addressed by the 3rd party vet inspecting the ponies' care shows he is truly committed to the outstanding health and welfare of his ponies. I believe the park's knee jerk reaction to fanatic animal activist extremism is shameful. Since when is screaming obscenities and yelling at parents holding their children a basis on which to form public policy? God forbid we jump every time ignorant and bullying activists believe they know better than horsemen & women who have dedicated their lives to these noble and gentle animals. The city and the park mustn't cave in to uninformed and ignorant hysteria which in no way reflects the feelings of the vast majority of the Los Angeles equestrian community. My understanding of mission of these folks is that petting zoos will be next, then animals in motion pictures and films, horse shows and events, and ultimately any riding of horses altogether. What will the park do when the LA Zoo comes on their radar? Close the zoo? Re-home all those animals like Steve has had to do? Please keep the pony rides and listen to the voices of the LA Equestrian Advisory Committee and your local Los Angeles equestrian community. Thank you for listening, Sam

Dear Friends at Parks and Recreation, I wanted to take a moment and echo my support for keeping the equestrian projects at Griffith Park. The Pony Rides have been a cornerstone of the community, often giving children in our community a rare first experience with these animals. Being able to interact with these beautiful animals in the middle of our urbanized city is an important link to our past and to honoring the role these animals have played in lives, both past and present. There must be a humane way to keep a balance where the animals are happy, well maintained and able to interact with people in a meaningful way. There are well documented studies showing the connection and access to horses and ponies at a young age (Re: <https://equineassistedtherapyaustralia.com.au/wp-content/uploads/2020/06/Equine-Assisted-Therapy-and-its-Impact-on-Cortisol-Levels-of-Children-and-Horses-a-Pilot-Study-and-Meta-Analysis.pdf>) as an important stimulation to child development and maintains healthy cortisol levels in the animals themselves.

I believe we want to find a safe transition for the pony rides, protecting the animals and finding a way that this can be to keep this experience in our community in some form.

This is an 80-year-old tradition Griffith Park and dates back to Gene Autry in the Griffith Park area. This has been handled poorly by LA Parks and recreation since this is a one-sided decision. This should be handled with historical importance and proper representation from the public in favor of this tradition. The equestrian community is strong and knowledgeable in Los Angeles. I am in my sixties and have vivid and fond memories of the pony experience as a child and carried with me through my lifetime.

Instead, the woke leftist were paid \$25.00 per hour to protest the old ponies that were taken exceptional care of. When I visited Griffith Park last week, the protestors really didn't know why they were hired and told to scream "animal cruelty". The contrary. These geriatric horses were given an important task to fulfill in the last years of their life.

This protest is ridiculous, and the L.A. Bureaucrats must listen to all their constituencies and help same this tradition.

I patiently have been waiting for a response.

~~Withheld Name~~

I am sad to learn that the City is considering not renewing the lease for the Griffith Park ponies. The city should not let a few extremist activists end an attraction that is one of the few ways small children in this city can interact with animals. My daughter had an opportunity to ride the ponies, but my son (born not long before the pandemic) never has, and I will be very disappointed if it is closed. Please extend the lease to give the operator an opportunity to respond to the policy changes recommended by the third-party equine expert.

I think the pony rides should stay in Griffith park. They provide a crucial outdoor activity for families of all income levels. I feel that removing the pony rides sets a very concerning precedent, that if a few people are rude enough and scream loudly enough, the city will listen, regardless of whether you are correct, and regardless of what the rest of the community thinks. If you have legitimate reasons for not renewing the contract, you should say what they are. Instead it looks like you caved to pressure from extremists.

Thank you so much for shutting this horrible place down. Horses do not deserve to be treated like that. To see their sad spirits broken like that was just unbearable at time. I hope they go to sanctuaries and away from that horrible owner.

As a child, I was taken on a pony ride (not at Griffith Park). It can be a great experience that can get children used to ponies & horses. I hope there is a way to provide pony or horse rides in a way that's fair and humane to the animals.

It sounds like the concessionaire made some serious errors, such as the lack of dental care. After the initial report came out, they improved the pony rides but not enough. Maybe a more humane and trustworthy concessionaire could be selected. While animal rights advocates can alert us to abuses, >>>I don't think decisions should be made just to placate people who may be philosophically opposed to ANY riding on horses or ponies or any keeping of animals in captivity.<<<

In addition to humane pony rides, a petting zoo might be good if it was okay for the animals.

Maybe kids could be taught how to care for animals? Maybe the city could partner with 4H and which older kids could learn to raise or care for animals, such as ponies? (Not that there's room for a full-on farm there.)

Finally, an interactive exhibit could educate kids about how animals live in the wild.

It's clear by all the reports and by visual confirmation that the ponies were and are well cared for. That being said, if you did not want to renew the contract, why did you not go out to RFP for a new concessionaire? The fact that you closed the whole operation for something that you said was not required (reporting on deceased ponies) tells me there is something fishy going on. Perhaps you are embarrassed now to walk back your decision but I think it will exhibit courage to say you acted too quickly without all the facts. Pretty amazing that low income families can take their kids to connect to a horse for \$5. 70% of the 200,000 tickets sold each year are to low income families.

Keep in mind that the majority of the people who want this closed do not understand horses. Perhaps they mean well but I can promise you they don't know what they are talking about. If we accept what they are saying, that animals should not be for our enjoyment, then we need to close the zoo, and we need to donate all of our pets to a pet sanctuary.

Comment

We live in a democratic society where the voices of the people are heard, but to allow one person to make a decision that would have an impact on so many children without consulting the general public is an outcry. I see this as having a dictator in public office. I request this issue to be instated on the Los Angeles City Council calendar and for the voices of Angelinos to be heard.

I am writing to express my shock and disappointment in the decision not to renew the permit for the Griffith Park Ponies.

The decision seems to be based solely on the efforts of an extreme radical group. Based on the reports from the independent consultant there is no evidence that the animals are being mis-treated. The independent consultant hired by the parks department found "the working conditions to be satisfactory and did not witness any gross violations related to the care or the treatment of the animals on exhibit". The letter to Mr. Weeks wherein he is informed of the decision to shut this beloved landmark down confirms such. And upon re-inspection, the consultant noted numerous recommended improvements had been made and stated in her conclusions that "the improvements and ongoing changes made to the operations of the pony rides, including new policies and practices, meet the current legal standards set forth by California Health and Safety Code 25998-Standards for Horses for Hire and Animal Welfare Act".

The reason stated for deciding to shut down Mr. Week's business and a treasured activity for Angelinos is because he failed to report the death of some of the ponies. The statement that the "lack of communication" is the reason for not renewing the contract contradicts the fact that no notice is required. Essentially what the city has done is punish this organization even though they are operating within the established standards and requirements.

I note that no time was wasted in calling for replacement concessions, and in a city plagued with corruption it makes me wonder if there is some ulterior motive in shutting down the Griffith Park Pony Rides. Does the committee already have someone they plan to replace this historic establishment? Perhaps a developer that helped fund the PAID protesters?

I urge you to reverse your decision. Look at the facts, not the propaganda of a small group of protesters who don't even live in the community. Save this long-standing beloved attraction. Do not take away the only opportunity that some children have to interact with animals where their experiences can develop into a lifetime of caring about animals. Do the right thing - Save the ponies!

Sincerely,

[Redacted Name]

PLEASE keep the pony rides open! So many Angelenos, especially working class families, come here to create happy memories with their children. The people of this city have had so many things that bring happiness taken away from them over the last few years. Don't add insult to injury by shutting down the pony rides. If there is a concern about working the ponies on hot days, just add shade and misters to the track. These animals are not being abused. Do not concede to the demands of a shrill minority of misanthropic animal rights nuts. Instead, help the working families LA continue to have a safe, affordable form of recreation.

I am in support of continuing the pony rides at Griffith Park with oversight to assure the proper treatment of the animals. It was a fond part of my childhood growing up in Los Angeles and should be made available to current and future generations. Please reconsider this action and reinstate the program with the recommended concessions. Thank you!

My children grew up in Los Feliz and started riding the ponies at age 3 it was such a joy for them and all the other children, it would be a shame for you to discontinue such a positive activity that's in our community. The horses were always healthy and clean and it was the positive experience for everyone involved..

Please don't close the pony's it's a really beautiful commodity for all of LA county. This is a 74 year old stable and could qualify for a historic landmark.

Sincerely [Redacted Name]

As a lifelong Angelino, I remember enjoying the Griffith Park pony rides as a child. It was one of my few interactions with animals growing up in an large city setting. As an adult, I have worked with animals and veterans, children, and formerly incarcerated peoples in a PTSD treatment setting. The bond that can be established between humans and our animal relatives is priceless. However of course that interaction must occur in a healthy and nurturing environment. There is no comparison, as was suggested on the special meeting call today 12/15/22, between humans and machines vs humans and animals. Very troubling was the process of closure by LA City staff. This was NOT a transparent process, per city standards and protocol. With the history of political abuses against the communities of Los Angeles as well as the most recent egregious actions of some city council members it is most important at this time that the future of pony rides/ animal-human interaction at the Griffith Park space be a transparent one that allows for professionals in fields relevant to making a decision about pony rides get a seat at the table to offer their professional expertise. Lots of talk about how to develop the future of the space, that talk must include under what conditions, if deemed as a worthy operation by professionals, the pony rides could return. Anything short of that is a blatant show of caving in to those that oppose the rides, and based on much of the public discourse, the opposition is based in non factual arguments as they relate to our animal relatives and how we can go about having healthy interactions. Thank You.

Hello, and I encourage you to maintain these rides open. The children, the adults need contact with nature, with these majestic animals that we cannot have in our homes. I have ridden since the age is 6, mostly rental horses and it has brought joy and a love of nature as I walked through the surrounding world and given me a sense of love and responsibility for animals. I am currently a biologist and that wouldn't have been possible, hadn't it been for horses. Please reconsider. [Redacted Name]

Please keep the Pony Rides open!

The concession has been there 74 years! The experience of riding ponies is a unique, healthy, outdoor for all the young children to enjoy. The rides service a large local community. Adding an educational component would be easy.

It is a shame to close this special attraction just as people are getting out and enjoying the outdoors. It is a shame to take away part of the Griffith Park history.

[Redacted Name]

Comment

I have watched the pony rides every weekend for the past year. I see that this tired old concession is not an asset to the children and certainly not to the animals. I have a vision of that entire space re-imagined and providing true enrichment for children. We could have lessons, otherwise unaffordable, for many families, to truly teach skills such as: art, dance, martial arts, musical theater, gymnastics, etc. We could set up a beautiful learning center where children could develop a skill and build self esteem, so when parents say "good job" it won't be just for sitting their behinds on a miserable horses back and riding in a circle, but for actually accomplishing something. I have shared my vision with many parents at the concession, and all were extremely supportive and would be excited to join. It could be affordable and bring in considerably more funds for our city, while providing a great opportunity for children. Sometimes it's necessary to say "good-bye" to an antiquated activity whose time has passed. I have just listened to the two-hour public comment and have to rebut some of the statements made by the pro-pony ride callers:

1) So many have stated how important it is for children to "interact" with animals. As a person who has watched the pony rides every weekend for over a year, I can tell you for sure that there is barely any interaction at all. Child after child is set on a tethered pony in the turnstile for the purpose of a photo/video-op, often screaming and reaching for their parent. The child never looks that horse in the face before or after the monotonous ride or is encouraged to even say "Thank you". I have documented it at between 90 to 95 percent of parents who just take their child off the horse and carry him/her out the gate, with out a glance at the horse. Please go check it out.

2) These pony ride enthusiasts state that Stephen Weeks "loves" his ponies and there was no neglect, yet the independent veterinarian assessment reported saddle sores that couldn't heal because of constant irritation, untreated dental conditions, and depression. Before any activists ever showed up or even knew Zohra Fahim, she stood and unobtrusively monitored the pony rides every weekend for two months. She has plenty of video of unhappy, abused animals. The turnstile ponies were often not given even one water break for the entire seven hours of walking in circles in 98 degree heat -- this was July-August of 2021. It was only after animal advocates showed up with protest signs in September that the ponies began getting water twice a day, and the staff made sure they broadcasted it over the loud speaker that "the ponies are now having their water break" -- damage control -- too late. Actions speak louder than words -- they do not "love" the ponies. It's about sending as many people through the line as possible -- like an assembly line -- \$\$\$\$\$\$\$

3) I recently witnessed Luna, a pony who still has a dram of spirit left in her, refuse to walk the turnstile and shook her head from side to side in protest. The staff member pulled her forward by the face until she had to walk. After this happened several times, she finally violently reared her head backwards attempting to free herself from that horrible device. Only then, when I said, "Take her off! This is not safe for her or the children!", did they finally lead her back to the corral.

4) It was also stated by those who support the rides that the horses are "so happy to come out and be with the children". Not so! However, any honest person will tell you that when the time gets close to 4:30 p.m., even those depressed ponies, in a state of learned helplessness, perk up a bit, because they instinctively know that they will be able to be untethered from the horrid turnstile and be able to go back to the corral and away from all the noisy humans. They ALL want to be free from what they are forced to do day in and day out. Some of those elderly ponies walk as if arthritic and in awful pain. I think one of those couldn't stand it anymore and died, because I didn't see him anymore.

What is amazing is that there are actually humans, who share this planet with us, who can look at those ponies -- especially those who walk in circles all day, shortly tethered to the turnstile, and actually state that this is not abuse and that the horses are not suffering. I have empathy for humans and all living beings, and I can tell you those horses are NOT happy to face their days.

As a society evolves, decisions can be a bit painful for some. Growth is messy, but meaningful change is necessary with the evolution of human consciousness. Thank you for being on the right side of history. How ridiculous it would be to open pony rides again after closing one down. There are many other options for child/family enrichment in that space, without including live animals. There are already three local sanctuaries where children can be taught properly how to truly engage with animals -- happy animals. Please rep

I support keeping the Griffith park pony ride contract in operation!

I am in favor of keeping the pony rides in Griffith Park. While I understand the need for diversity in recreational activities, children modernly do not get a lot of hands-on time with animals, and the pony rides here ensure that children of all socioeconomic backgrounds get to enjoy interaction with animals, something that many kids in disadvantaged homes cannot get elsewhere. For many of us, pony rides were a formative experience that allowed us to connect with animals outside of dogs and cats, and I personally found such experiences enriching enough to pursue a career in veterinary medicine. I would hate to see kids today robbed of such an emotional experience that might dictate their futures and at the very minimum, enrich their spirits.

Griffin Park's ponies are well cared for and I believe that the pony rides provide a valuable function for the park and the ponies. Furthermore, "cancelling a Vendor's contract with the city for not reporting on animal deaths due to extreme old age, when no such requirement had ever been required of that Vendor is not in good faith, and disturbing. How can a person know to do a task that they have not been asked to do? Punishing the pony ride under the guise of "lack of transparency" to the *city* not being transparent to the Vendor of its expectations is ironic at best, and negligent and punitive at worst.

I am requesting that the Griffith Park Ponies remain open. The protestors don't understand anything about the condition of the ponies or most importantly what will happen to these older ponies after this is shut down. This is a place that all families enjoy coming to and bringing their kids to learn about all different types of animals. It is a great introduction into ponies and horses for small young kids and it was something I grew up doing myself. I hope you reconsider and allow these amazing family business to remain open instead of listening to a few crazy protestors.

I grew up in the greater Los Angeles area and spent many weekends as a child visiting my aunt and uncle who live in Los Feliz. We would enjoy time in Griffith park riding the train and also the pony's. Now that I'm an adult I've had the pleasure of watching the joy on my niece and nephews face as they ride the pony's similar to the way my cousins and I did. Please don't get rid of this beautiful experience. So many fun memories made for kids who would never have the exposure or opportunity to be around such magnificent creatures. I still have a love for horse because of this experience.

Thank u for your time

Growing up we used to ride these ponies. As someone who lived in a suburban area, the opportunity to come close and interact with them was such an important and nostalgic memory for me and my sisters. This was a valuable experience for people who can't afford to have a horse. I love seeing the joy it brings to my niece and nephew and always looked forward to bringing my future child here. I will be devastated if this closes for good. This would be a huge loss to the LA culture and heritage.

Our family has lived in Los Feliz since 1948. Our entire extended family is now close to 50 people. We are all shocked at the decision to close down the pony rides. They have been a tradition in our family going back three generations. I still have photos of me riding a pony when I was two. The pony ride was even more popular than the train. It was an integral of our childhoods. I am a supporter of animal rights. However, riding horses is not an exotic or abusive tradition. We never saw any signs of abuse or neglect over the decades. I hope this terrible decision can be reversed. There are many critical issues in our city that demand our attention and action. The pony rides is not one of them. Please undo this as soon as possible.

Please keep the pony rides. My three off spring all enjoyed it and remember it even though it was many years ago when they were young. It truly has been a bright spot for Los Angeles in this current sanctuary city crime infested jungle.

Comment

As a 7th generation angelino, (My ancestor was an early mayor, William Henry Workman, who not only established the parks and library system, he was the City Treasurer who brought the water to Los Angeles)

growing up in Los Angeles, the pony rides were the highlight of my young life!

Being able to afford this very special occasion for a low-income family was a very big deal! They were my first experience with horses, before we could afford anything like riding lessons or summer camp, or any of those things that cost so much more money for a young family.

They inspired my love and work for horses, which still continues locally in the area, I figure that I spend more than \$100,000 a year in local horse events and the local horse community.

Without the pony rides inspiration, I would not be here to spend all that money every single year for most of 55 years now.

I know that this is the case for most of the equestrians who grew up in Los Angeles, the pony rides were such a big deal to us, and inspired us to continue our lives involved with horses.

I bought a pony from the pony rides when I was 14 years old, and that was the first time that I had seen the behind the scenes space. I still continue to help people purchase or rehome the ponies from the rides and thus, and able to actually see and handle the ponies, which are very much loved and always in better condition than in most sanctuaries. The current operator, Steve weeks, does not abandon them in old age, and as the operator of a business that has existed for 74 years, obviously there have been many many many aged ponies to have come and gone. He keeps them until the end of their lives, in a space where they are happy, comfortable, loved, and very well cared for.

The most important thing about losing the pony rides, is that the low-income, and people of color, the demographics that make up 71% of the Los Angeles population, would be completely disenfranchised from ever having the opportunity to love a pony in their young lives. I can't tell you how important Ponies are to Young children, and how are young children supposed to be allowed to have something so special, if it is removed? Local Equestrian activities are BILLIONS in local revenue and encompass many, many small and large businesses.

It must be noted that the small group of protesters is an out of town organized group. They are not Angelinos. They have not grown up anywhere near the pony rides, nor do they care about them. They have suggested that they be rehomed to sanctuaries, when their home is already a sanctuary. And, many of the sanctuaries on their list, are wildlife sanctuaries where the ponies will be used as food for the lions and tigers and wolves. This is important to me. They should be allowed to live out their lives where they are loved and cared for in a home they know.

Unfortunately the Los Angeles Recreation and Parks was overly influenced by a very small, non-local, but rather violent group, they have been arrested for threats of violence, they have sent death threats to Steve weeks!

Zahra Fahim currently has orders of protection against her for violence!

They have been arrested for threatening to punch a pregnant patron of the pony rides! we cannot allow these extremist groups to take over and ruin the enjoyment of 71% of the Los Angeles population! To me, this is a racist and elitist attack on the Multicultural and multiracial makeup of the city of Los Angeles! Horses have always been an important part of Los Angeles, as is the multiracial diversity that is welcomed here.

I'm sure everyone at KPCC knows that the original 17 citizens of Los Angeles were mostly people of color, only three were white. The pony rides are one of the few things available to low income people of color, and must be allowed to stay.

Sincerely,

[Redacted signature]

I am against the closing of the Griffith Park Pony Rides. I am a 60 year old woman and was first exposed to equestrians as a child at the pony rides at Griffith Park over 55 years ago. As a latina, my parents could not afford lessons or even less to buy or keep a horse for me.

But because of the exposure to the pony rides, I went on to develop a love of horses and that encouraged me to get a college degree so I could afford my passion. I now own 3 beautiful horses. I also exposed my son when he was young to the ponies and have wonderful memories and pictures. Please do not deny other young children from experiencing equines. This is such a great way for exposing under privileged children to horses at a very low cost. I am in support of keeping the Griffith Park Pony Rides open. Many of us started our love for horses with those ponies and it grew where we ourselves became horse owners. These ponies provide a therapeutic service to our youth just like a seeing eye dog provides a service to the blind. Yes, they are working animals. I work, my husband works, and you are there working. Ponies get paid with the food they eat, they get medical and dental coverage, they get hugs and love from the children, they get pedicures or new shoes every 6 to 8 weeks. And just like some people that when they retire, they get lost or depressed with nothing to do. Keep the Griffith Park Pony Rides open.

There are really two issues here; abuse of power and denying the low income community residents of a service that has served and changed the lives of thousands of children.

GM Jimmy Kim, without discussing the issue with RAP or the Equine Advisory Committee made an abrupt and thoughtless personal decision ripping a community resource and eliminating jobs during the holiday season. Going against veterinarian advice, and without consulting the community he "serves". When he was questioned, he made up the reason due to the death of a 38 year old pony (this would be equivalent to a 120 year old human passing away), despite his own words stating "The operator is not required to notify the City of deceased animals." (Jimmy Kim) Best case he is lying, worst case it was an intentional set up. Neither are desired of an employee of the city in such a high power position where transparency, trust, and integrity are of the utmost importance. This is tyranny, not leadership.

Mr. Kim rudely declined an opportunity to transfer the business. For a public official to be so dismissive can't be tolerated, and only shows his personal issues or ulterior motives.

The second issue is the removal of an important fixture of Los Angeles providing an affordable service to underserved children, families and children with disabilities. By removing this 74 year tradition from generations of Los Angeliens is heartless, cruel, and only highlights of ignorance of needs of our community. If the goal was to elevate the experience, this could have been done without robbing the families of the existing service. Hundreds of children were looking forward to spending their Christmas break with the ponies they love. A transition is the least that everyone deserved.

One last thought. As this story was exposed to the equestrian community, one thing I kept hearing from equine professionals, including veterinarians, an Olympic rider, an equine therapist, etc. is that they all received their start and love of horses at this pony ride. Imagine all of the lives they've touched and inspired due to that love and dedication. It's the seed of passion planted there that is reflected to the world in countless ways. This decision will negatively affect generations to follow. Horses are healers, and save lives.

Having kids being able to interact with horses is so rare in LA. It builds connection with animals, community building with other riders, responsibility to take care of another living thing and courage. The large stables are too expensive for most kids but pony rides is a affordable introduction to horses. Please save the pony rides!

My allowance for the continued existence of the pony ride & livestock concession is Conditional. After reading Dr Sachar's progress report #2, I urge the powers that be to contractually MANDATE the continued INSPECTIONS at quarterly intervals to hold the concessioner accountable to maintain the recommended improvements, as well as MANDATE the timely provision of comprehensive Veterinary Reports as to cause of (any) death(s). The animal welfare depends upon a watch-dog enforcement to 'encourage' consistent compliance. In addition, as recommended in the report "It would be of greater value to the community for the concession to incorporate educational opportunities to the public."

This is the ONLY condition that makes an animal's sacrifice of value. Young people should be EDUCATED that animals are not just here for our amusements. It wouldn't take much to add an educational VERBAL (no cost) component. And for a minimal cost: photographic, video, or other media could complement any verbal presentation—much like educational tools employed for children in museums. Children could also 'adopt' a pony for the day and learn about/participate in their grooming, feeding, healthcare. And learn about equine ancestry and their Wild counterparts sustainability & protections. The educational options are infinite. LASTLY one more condition, on whether to allow the pony rides continuance, would be to contractually MANDATE ENRICHMENT (as recommended by Dr Sachar) for ALL the ponies and livestock. This low-cost, essential provision could be incorporated into the educational aspect...by introducing the children to the importance of animals at work AND at play. All living things should be valued. Otherwise, the protests will rightfully continue. Thank you.

KEEP THE PONY RIDES AT GRIFFITH PARK!

Comment

I feel like the removal of the pony concession is a great loss to the people of LA. I grew up with easy access to farms, ranches, horses and other livestock, wildlife and outdoor activities. Almost all of these beloved spaces and encounters are gone forever. I am a pediatric RN, and have experience with therapy animals including equines. The benefit to children is immeasurable. Being around ponies gives children a feeling of peace, empathy and belonging. Its good for their mental and physical health. It helps children develop into healthy adults with happy memories. Please do not remove one of the last outdoor activities that is child and family friendly. I am an expert horsewoman, with a thick horsemanship resume, and have no concerns about the well being of these ponies... other than their fate if they are disbanded and disbursed.

Griffith Park Pony Rides serves all the children of Los Angeles with a low cost way to learn about livestock, the care involved, the love we give them. Animal care teaches compassion for other living beings. It is not abusive to have animals or to use them for service, work, entertainment, and even food sources. In this day and age, people think their food comes from the grocery store. These children need to learn about farming, animal agriculture and the work that goes into it. The pony rides also help special needs children in many ways. For children with cerebral palsy, the movement of the horse actually loosens up the muscles that can allow them to walk.

There was no abuse of the ponies. I'm a registered vet tech in CA and former Disneyland employee who worked at the Big Thunder Ranch petting zoo). I looked at those ponies from the perspective of a vet tech, Disney petting zoo employee and mom. The ponies were healthy and looked clean, happy and the area was kept as clean as Big Thunder Ranch. The joy on the children's faces was wonderful. The confidence first time pony riders gained from riding the ponies was palpable. The pats, first cautious, then confident. That isn't something that can be gained from inanimate objects.

This is a decision of greed, disinformation, defamation, libel, slander, and not what the constituents most affected want.

PLEASE keep the pony rides. They are how I first fell in love with horses and gave me my life long career. I know firsthand the difference horses can make in a child's life (adults too for that matter), and for many hundreds of kids the Griffith Park pony rides is the only way they will ever discover the magic of horses. Please don't let the crazy Animal Rights activists ruin one more wonderful business.

The pony rides are integral part of childrens development of learning about animals. It is an introduction to ponies and horses for many kids that cant afford formal riding lessons. It teaches them that ponies and horses are fun, and kind and not something to be feared. Its how many equestrians learn about the world of horses and get their start. It's also just a place for children to experience the joy of riding a horse for the first time.

Please allow the ponies to remain at the peoples park Griffith Park! Do the right thing

The closing of the Griffith Park Pony Rides is sad and shocking. It would be one thing if these animals were abused and not taken care of. However to make a decision because the owner failed to notify the Parks and Recreation of ponies dying is absurd. He was not obligated to do that.

His ponies have lived to an old age. Many equines die or have to be euthanized due to colic which is nothing that can be foreseen until there are symptoms. Many times by the time we as owners become aware that our equines are suffering from colic the damage has been done. There is no ongoing vet record for this unless you treat multiple times and many times it is to late. There are many reasons a horse colics.

Being an avid equine lover and owning them for years I do understand people that do not have these beautiful animals thinking everything is abusive. These ponies need exercise and build up endurance each time they are used. To say it's cruel and that they are being abused is not true as stated in the vet report.

Many city children get the chance to experience the magical feeling when they get to socialize with these ponies. Horseback riding has been used for therapy for years.

It is with an open heart I pray that you continue this unique opportunity to allow our children of today to experience the joy.

Griffith Park was always an exciting place for me as a child and growing up riding my horse in the beautiful hills.

This space should be kept as it is.

Many people do not understand the real love these animals give and get.

It is sad that you are not even giving the owner a option and are forcing him out of business.

If you see through this o believe the fight is honestly over the space and you being able to build something else that will bring more money. It's not about the happiness these ponies bring to many.

I absolutely oppose the closure of the Griffith Park pony rides. The ponies are well cared for and provide an irreplaceable outlet for children to interact with animals. The parks and recreation department seems to be kowtowing to a small group of loud, uninformed, animal rights extremists who know absolutely nothing about animal care, most especially when it comes to equines. They have proven this over and over again. They continually misrepresent the behavior of the ponies as "sadness" and "exhaustion" when those with knowledge about equines, understand that is a relaxed body posture that is more a signal of contentment. Their solutions include placing the ponies in so-called "sanctuaries" that they clearly failed to investigate, since one was a wolf sanctuary and others routinely feed horse meat to their animals.

It's time for the people who are supposed to be representing the citizens of Los Angeles, to listen to them. A clear majority, is in favor of keeping those pony rides exactly where they are.

Please keep the Griffith park pony rides open. It's a great ploy for children to see , ride and learn about horses. I have been the horses are not abused and in good condition. I was there once and they had apologized to us for the wait but the ponies needed to take their break. They put the ponies first.

Hi. I am a disabled equestrian. Growing up in and around the Griffith Park in the late 70s, when the Hillside stranglers were dumping bodies. Then we went to Eaton canyon, San Pasqual, and now Hanson dam area- long time lover of equis.

And long time advocate for parks and Rec preserving and caring for our parks.

Until now.

So bizarre!. This attack is on the pony rides.... Makes zero sense.

I can't tell you how many countless times, a pony or a horse has saved my life and countless others. For children this is one of the most precious experiences they will have in a lifetime.

To take that away for selfish reasons like money or a plant treaty is heartless.

And if you believe Zorah and her gang, that borders on insanity.

Ponies love children, and children love ponies..it's simple!

They are not entertainment....

they are an animal that we have been honoring for centuries. They honor us, and we honor them. A symbiotic relationship that's absolutely beautiful.

It's cruel what has gone on. It's very unusual.

There should be a reconsideration for the children and ponies of Los Angeles.

Thank you

Please reinstate the pony rides. They are an essential part of the Griffith Park experience and have provided joy to thousands of children over the years. The ill informed protestors should not be allowed to use their, lies, deceit and bullying to deny Angelenos this wonderful human animal interaction. The ponies are well loved and well cared for. Do not believe the lies.

I would like to request a 90 day moratorium on the closure to allow for a public forum of discussion. Most Angeleno's knew nothing of this until the LA Times article came out last Friday. From my understanding and reading of the documents the owner of the pony rides seems to be being punished because Mr. Kim feels he disrespected him by not reporting deaths, when reporting is not required. I listened to the meeting yesterday, and it appears that is what exactly Mr. Kim expressed. This closure and non renewal of lease needs to be placed on hold and a deeper understanding needs to be evaluated. Thank you. Kathryn Shafer Additionally, the number of "anti pony rides" on the zoom meeting was measurable as to the individuals suggesting; a carousel (seriously?), and go-karts, have them never been 2.5 miles into Burbank? I suggest a meeting of local Los Angeleno's not loud animal activists that are from other parts of the country. Thank you.

Comment

Please continue the pony ride at Griffith Park

Please don't remove the ponies/rides it's a major part of what families do with young kids and they are fun. My children did it and so did I when I was a kid so please keep this tradition for the future of children who will want to make memories too.

Keep the pony rides.

Please extend the contract. The loss of such a historical site in our city would be irreplaceable. It would completely change the character of Griffith Park, removing the place where families can create unforgettable lifelong memories for their children. You are changing the culture of our city for the worse. Please reconsider.

Please continue to have pony rides at Griffith park. Please do not take this away from Los Angeles

Please keep the pony rides in Griffith Park. The vet report was fine. Please don't take away recreation for the public, especially children.

Can you please keep the pony rides?

Griffith Park Pony Rides has been part of our lives for generations. My daughter (almost seven) still talks about her second birthday party there. Please keep it open so we can continue to make memories for generations to come!

I am appalled that the Pony Ride contract has been CANCELLED without consulting the constituents that it serves- low income families, middle income families - and the horse community at large. PAID protestors that terrorized the children with VULGAR language and threats have NO knowledge of proper equine care.

It is my understanding that the decision to cancel the contract was made by 1 person without proper input from the City Council or incoming Mayor. I have read the 3rd party equine vet's report and it CLEARLY states that the ponies were receiving proper care. I have owned or ridden horses for over 50 years. I have had my children ride the ponies when they were too young or scared to ride the "big horses". My daughter developed a LOVE of horses from her pony rides in Griffith park and "graduated" the the big horses at summer camp when she was a bit older.

I would like to keep the pony rides at Griffith Park. I think it's an important experience to be available for kids and young people, especially in LA where many kids do not have access to animals and outdoor activities. I think it's a shame that "animal rights" activists with no real experience with horses/ponies can have such sway and bully such an establishment. Horses and ponies are well loved by those who work with them, and true abuse is important to recognize, but this is not it.

The pony rides are being shut down for reasons other than what has been stated in the many meetings I've heard. It seems to be a unilateral decision and I'd like to see all internal communication leading to this decision. I'd like to request all internal pony ride communication by Parks and Rec. I'm devastated by this attack on horse loving families of Los Angeles county, and beyond.

Please do not shut down the only pony ride place in LA. It is such a joy for my kids and many others.

The pony rides should stay. They are fine, well cared for, and many horse people have gone over to check on them and reported back. The protestors do not know anything about horses/ponies and are being paid to protest. Someone needs to trace back where this money is coming from to pay protestors. Something isn't right here. Why hasn't the powers that be investigated that? The pony rides are a institution of Griffith Park and should remain. My love of horses began at the Griffith Park pony rides in the early 60's and went on to own my own horses. I am all for having the pony rides stay and continue.

My kids loved riding on them as do my grandbabies now. Such a wonderful part of the park. Hate to see them leave

The ponies are essential to introducing children to horses and a very e-special experience which may kids do not get to experience often. My own son had his first pony rides there. The ponies are well cared for and might not all end up in a good situation if closed down.

The GPPR should remain as a historical icon of the park and city, an opportunity for families (underprivileged and otherwise) to interact with buyers, and for the ponies to live their lives in the safety of a purpose, home, and herd.

The pony rides in Griffith Park is a landmark and asset to the city of Los Angeles. The pony rides gives children an opportunity to connect with animals. Furthermore the pressure and protest from extremists is uninformed slander. Independent veterinarians found the working conditions of the animals to be good. As a lifetime horse owner and Angeleno I support the pony rides. This is not animal abuse it is a witch hunt.

You have made a mistake. The Griffith Park Ponies have historical significance as well as therapeutic value to children. It began a lifelong relationship with horses for me.

The Griffith Park pony rides are a landmark. A guaranteed smile for an hour. We drive up from Camarillo we do the pony's the go to Porto's.It's my Grand Daughter and my favorite activity. We were heartbroken to hear ponies wouldn't be available to the vass majority of children who would love the opportunity to ride. My children rode the ponies in the 80's. And now my Bonnie. Please leave the historical site for the thousands of children given there first experience with horses. Please bring it back. We dont need more Disney buildings ir lkeas or Costcos.

The pony rides are often the only way children in large urban cities have a chance to interact with equine. Doctors are always pushing to get the kids out side and moving. They learn empathy from direct contact with animals. So many people in Los Angeles live in settings that don't allow pets. These ponies provide this as well as out door activity. It is sad and most unfair to deny them this opportunity. Most families today can not afford Lakers tickets or Rams or Dodgers tickets. This allows them to build memories as a family for their children. I think the fact that Mr.Weeks in being expected to be so transparent about the deaths of these ponies 3 of whom were euthanized by a veterinarian with a schedule 4 narcotic that they are required to keep tight control of and documentation so they can keep their license to practice medicine is unreasonable. The contract does not require it so why is he being denied a renewal on thar basis. After all that is all we the tax paying citizens of Los Angeles are being told. I believe 12 protestors is not a sufficient voice to close a long standing business that serves so many in this community.

Love the pony rides. As a horse owner for over 25 years I do NOT see abuse or neglect. I rode the ponies and a child that helped to lead to my life as an equestrian.

To ruin a man's business and make dozens of ponies homeless over false claims of neglect and/or cruelty is CRIMINAL. Ponies and horses are PURPOSE BRED to do this job for MILLENIA, and to take that away from them is cruel, and will likely end their lives early. They are not pets, they are OUR PARTNERS. Humans and equines have evolved together to create civilization, and we owe it to them to steward them in a manner that makes SENSE.

It should remain open. It is a landmark and they take good care of the ponies. Stop with all this Woke stuff!!!

The ponies are a staple at Griffith Park and are not abused.

Horses are used to going round and round in round pens for heaven's sake.

Horses & ponies have been selectively bred for centuries to be partners with people. They enjoy the connection, and the work. It's literally their joy; it's much like herding dogs bred to work on ranches. They love the work & their people. Children learn to connect emotionally with an animal that reflects their energy. Horses create authentic people who develop skills of reading body language & its effects on others. Horses teach responsibility, self control, & hard work. These people will love spending time in nature with a horse & will want to continue to protect and preserve those spaces. There's not much better mentally, physically or emotionally. It's a much needed respite from urban life. It all begins with an affordable pony ride.

This is an important experience for children in the community and visiting children to the park. Horses and or ponies teach things to children that they can't learn anywhere else. These ponies help them to connect to animals and is quite thrilling for them to have this experience. Kids that have physical issues, mental issues, can participate and is actually therapeutic for them! Pony rides are a wonderful tradition for children and many professional equestrians started out at a pony ride. It would be a great loss for children to not have this available to them. The ponies are relaxing for the children and teach patience, and focus to these young minds. Please don't close the pony rides. We need these experiences in our society!

The Pony Rides were a great low cost and enjoyable experience. Most of the attendees on any given day were Hispanic/Latino, and being outdoors and having a great day with their families. If you replace this with something like bumper cars or a museum you are going to lose anything attractive about the concession and it'll just be another average concession. Thanks for being deaf to the public and only listening to the brats who scream the loudest.

These are well loved, vetted, and looked after horses with the facts on their side, not the protestors. For many families this is the only horse interaction they can afford. My fondest childhood memories are all with horses and I can only imagine the impact it has on thousands of kids! Please reconsider and save what's left of our rancho.

Comment

This is for the children bringing such fond memories to families. Please don't remove I had the pleasure of watching my children and now my grandchildren get to experience this. When telling my 4 year old grandson from Virginia he won't be able to ride next time he comes to California, he cried and cried. This is a disgrace you are closing this beautiful opportunity for families to have safe fun!!!!

Pls.. save the rural life in California

The Pony rides have been there for decades, my kids grandkids along with thousands of others have all been there, now someone wants to take them away? Renew the contract and keep this attraction going for years to come!

Done

Such a disappointing decision made by Jimmy Kim. Caving to paid protesters that have no idea of how take care of ponies. Screaming obscenities at parents and children. This has been a place where many children would get their only opportunity to interact with a pony. To put a man out of business because of these I'll informed protesters is a tragedy. I believe it may be against the Griffith Family Trust agreement. Ponies are gone. Steve Weeks lost hundreds of thousands of dollars. Shame on you, Los Angeles.

The pony rides are the most amazingly wonderful experience in LA. My kids went All the time from 3-6yrs of age. My daughter is now an international competitive rider and has a career in the equine industry... horses were her first love thanks to the Griffith Park Pony rides. I now take my grandson there and we enjoy a great time together .

Please rework the ponies. Safe conditions and let kids still enjoy animals :)

I have been a horsewoman most of my life, spending my entire career caring for animals. Race horses, polo ponies, hunters, jumpers, and dressage. I spent 30 years as an animal keeper at the LA Zoo, and several years as an Animal Safety Monitor on film sets. Retired now, I keep 3 equines, all essentially rescues.

During my career, I have observed animal rights protesters, generally kind people, who are unfortunately misguided and/or misinformed attack almost every aspect of the industry. While there are definitely abuses, and areas that need reform and oversight, these pony rides are not cruel or abusive. The ponies are well cared for, and expose urban children to animals. My first introduction to equines was pony rides, and it led to a lifetime, and a career providing quality care to many species, but horses have been a constant in my life.

These ponies are cared for, and loved by hundreds of children.

Where will these ponies end up? As a horse owner, I have seen the cost of good hay, veterinary care, board, and farrier care almost double in the last 2 years. Will they go to knowledgeable people who can provide what they need? Will they get passed from home to home as they are outgrown, age, or become difficult, not fun anymore, or too expensive.

Will they end up in cheap auctions, or sent to Canada or Mexico for slaughter?

The ponies are better off where they are, I have no doubt.

Please do not shut down the Griffith Park pony rides. Our children need a place to go and experience the joy of being with ponies and other farm animals, especially after the past couple years. Please do not ignore the science.

Ann Swinker, Ph. D., a professor of Animal Science at Penn State University found "Handling, riding, and caring for a horse or pony can develop a host of positive traits in a child, including responsibility, accountability, patience, level-headedness, empathy, kindness, and self-discipline."Oct 2018. Take this moment and credit a positive, collaborate with the owner and equine community and provide program's for children, especially low income children to develop traits and skills to become strong, caring adults. I hope you change your plan and support Griffith Park pony rides, and become an organization that supports children lives, not one that took away the opportunities to improve children's lives.

Kindest regards,

~~Christine Swanker~~

The pony rides need to stay. They are a valuable part of the LA environment and provide an inexpensive opportunity for kids to interact with animals. I also believe this was the vision and desire in the Griffith Park trust. LA does not own Griffith Park. It is a trust that provides the land to LA and violations of the terms of the Trust can and should result in LA losing the land. To have the decision to discontinue a beloved landmark because of ill informed activists by an interm manned position makes no sense. The current operator of the rides has done a great job of managing the operation and the ponies care. I am a knowledgeable horse owner from age 4. Not some paid activist.

The Griffith Park Pony Rides are a venue to be treasured- not harassed or threatened by PAID protestors. We, the people of Los Angeles County, demand an investigation into and explanation of how a single government employee can shut down a venue that has existed for over 70 years. Children of all income levels have enjoyed interacting with ponies. In a city of concrete and skyscrapers, Griffith Park offers a welcome refuge of calm, nature and PONIES!!! Today's adult equestrians started their life-long love and respect of horses from this (or similar pony rides in their hometown).

I am against the pony rides being shut down. The animals are well cared for. It provides a valuable experience for families who would otherwise not be able to afford access to. Its also a bad president to cave to radical protesters who stalk and threaten others yet are completely uniformed about equine care and needs. What does it say about our city, state, and country if we do so. Its wrong, and sets a very dangerous president. Protect our pony rides, protect our small businesses, protect our ponies, protect the equestrian community. You can make this positive difference. What do you want your legacy to be.

This is special to the community and if animal activists are concerned we should do more to help support the owners rather than to take the animals away and close the pony rides down. Interactions between horses and kids are such a blessing and so impactful for both, and its an experience that many might not have the chance to experience.

I would love to see the pony rides continue! It was the first experience my son had with horses and he now loves them so much, 8 years later. We have so many good memories of the ponies and hope that you give them a chance to remain in business.

Please KEEP the pony rides open.

Please keep the Griffith Park Pony Rides open for everyone. It is the the only contact many children will have with a horse.

The City of Los Angeles has to keep the pony rides. It is horrible that the children and horse lovers of LA won't have an option to affordable pony rides. This has been in LA for 46 years. Horrible that it is being closed.

Please keep the pony rides.

There will always be problems , but discontinuing the pony rides that may be the only thing in a child or persons life that brings happiness is not the answer . Please continue the pony ride

Please do not shut down the pony rides at Griffith Park.

Pony rides often are the catalyst that propel children to not only become Equestrian but to become a responsible caring adult.

Griffith Park Pony Rides provides a valuable and fun experience to low income families. The continued enthusiasm and demand for pony rides shows that this facility is much in demand and not outdated. It appears that the city has bowed down to a small but loud group of extremists who don't know anything about the management of ponies.if the owner wants to remain in business, please consider extending his lease. With correct oversight, it's a win win for everyone.

I need you guys to understand how important pony rides are to Griffith Park. It gives underprivileged children and handicapped children and Abel body children the opportunity to interact with animals. It gives so much enjoyment for the children. It's good for the well-being. And as for the ponies they are very well cared for. They are perfect weight. They are sound and happy. I really hope you re consider because the pony ride should stay

Comment

This decision at the very least is counter to every single mission statement and the essence and reason of the existence of the recreational department of the city of Los Angeles.

the decision to close the pony rides down, as well as to not renew the contract with Mr Weeks (as it has been the last six consecutive years) MUST be overturned NOW!

I think it's too late to avoid tens of millions of dollars in tax payers' money via cost the city of Los Angeles in warranted lawsuits (start with slander and libel to begin with and illegal termination of Steve Weeks concession, and continue downhill from there...)

I also believe that the woman heading the so-called animal activist quote unquote, group be criminally prosecuted but in addition, the recreation parks department as well as the city of Los Angeles mandate (as she has proven herself to be a physical threat and danger to not only the ponies but the children and families around the ponies and there is documentation to support this in the form of audio video and pictures) Again, that the district attorney's office mandate that she avails herself immediately of the help that is available by the city of Los Angeles to address her issue of mental illness so as not to continue to be a danger to the community the horses, our children or even herself.

I am an expert level Equestrian and horse owner (both international level competition professional and as my personal pet,) with decades of experience having rode for 15 years in Griffith Park a minimum of 2 hours a day bareback while ponying (in non-equine speak that is holding another second additional horse with a rope right next to mine) again at least 2 hours a day at least five six days a week for over 15 years.

AND I VOTE!

our children need the ponies

We need the ponies. That's the only other animal besides dogs, cats, birds our kids get to see. Please find a way to keep them. We love them and they are loved.

I watched my nephews, now in their late teens, enjoy the ponies when toddlers. I am a horse owner and drive past the pony rides every day on the way to work. I assure you that it is a much more fulfilling life for pony/horse to have daily attention and a "job" than to sit in a stall ignored. It appeared any concerns were addressed (and just like parents of children, even horse owners aren't perfect), so there is no reason to end these rides as it's always been an inexpensive and easy way for families across L.A. to enjoy animals. Please, don't let ignorant activists with their own misguided agenda ruin it for future children of Los Angeles.

The animals at the Griffith Park Pony Rides have been well cared for, beyond basic care, but rather exceptional care. These ponies need to walk a lot for their health, and they are lucky to get such good, regular exercise - the kids and ponies are good for each other. This was a low-cost way for kids to connect with animals in the middle of a city. An invisible bar was set for the owner and when he didn't see it, the contract wasn't renewed based on one person's discomfort around transparency. As a premier large city, this is not how our government should work. A few radical, anti-human/animal connection activists, who organized to start down this path and hijacked a reasonable, public process. We request a city council vote on the Pony Rides after public notice and constituents input. Reinstate the Pony Ride concession today. Do not cave to a few, organized extremists - the cost is too great for LA's kids and the herd of ponies.

I am opposed to the closure of the pony rides, and the way it has been handled by the city of Los Angeles.

Disappointed that the pony rides are going to be shut down. This was one of the most fun things my son enjoyed when he was little. It was affordable, easily accessible and he learnt about animals.

I would like to add my support to the Griffith Park Pony Rides. This has been a wonderful part of Griffith park and a great introduction to horses for many children. It teaches them compassion and kindness to see and touch these gentle creatures. They are well taken care of and the owners genuinely care for their well being. We cannot continue to let the few uninformed individuals close down these animal parks. If these people continue to bully these companies out of business, these animals will end up in far worse circumstances. Auction houses and slaughter houses are full of these horses that had a job and it was taken away by people that frankly have no clue what a good and decent life is for a horse. Thank you for your time and I implore you to stand up to these bullies and let Griffith Park Pony Rides continue to care for their equines and be a wonderful family experience.

Leave the pony rides alone! At 71 yrs of age, some of my fondest childhood memories are pony rides. Animal extremists have been known to lie about, and misrepresent facts in order to push their agenda. Don't bow down to their ridiculous demands! Show some backbone and keep the ponies for children today and into the future. The ponies receive good care which has been documented by a veterinarian that observed them. Why anyone would consider the death of a retired pony to be of any importance is mind boggling. Ponies are mortal.

Do the right thing. Keep the ponies in Griffith Park.

Renew the pony rides contract... It's an environmentally friendly historically relevant facet of the Griffith park and greater Los Angeles community.

Why would you lose the ability to let young people experience the animals, observe husbandry, learn kindness, compassion and proper treatment even in a very short time experience.

You could consider expanding that operation to include equine rescue, trail rides in the park, riding lessons and even environmental internships for kids. Other improvements to stewardship could include a model farm including the incorporation of a flock of small ruminants to weed abate the hillsides of Griffith Park to reduce fire danger as well, return tons of carbon to the soil and assist in increasing the numbers of native plants.

Please don't let special interest groups sabotage our pony rides. Our community, families, and children need them.

The closing of the Griffith Park pony rides will disproportionately affect lower income households and POC. These are amenities that are typically reserved for more affluent communities. The fact that this is being taken away is ignoring the affects it will have on these communities.

The Griffith Park Pony Rides are where my daughter first fell in love with horses. We became an equestrian family,, RESCUING many horses over the last three decades. Do not take the pony rides and the opportunity to see and TOUCH animals from Griffith Park.

There are fewer and fewer parks and attractions that allow children to be outside and connect with animals and nature and off of a screen, phone or tablet. We need to protect Griffith Park Pony Rides and preserve it for generations to come.

As someone who's daughter rode at both the LAEC and Rose Bowl Riders, and now trains horses, I can tell you how important the pony ride is. The pony ride connects the child rider and nature like nothing else, and this entry to love animals and respect them begins right there. The pony ride is especially essential for a place like greater LA where many children could not have this experience inexpensively except at a place like Griffith Park.

Please don't cancel the Griffith Park pony rides! those ponies are perfectly safe and happy.... why take them away ?????? the children of Los Angeles learn so much from interaction with ponies in a very safe atmosphere.... this value to the park is great...

Please keep the pony rides in Griffith Park. This is a gem in our city and allows underprivileged citizens to bring their family and enjoy the park!! My family has ALWAYS been animal lovers and you have allowed the squeaky wheel to shout down the city council. Thank you.

For decades children of Los Angeles have had the opportunity to ride the ponies of Griffith Park. My grandfather used to take me on Saturdays as a little girl. It was such a fond memory to share his love of horses after his participation in World War 1 as park of the English Calvary.

The shared history of horses and children is important to the past and the future of Los Angeles. The decision to not renew the lease for the ponies without merit seems politically motivated by one individual. This decision should be considered and public opinion should be considered before permanently closing the entire operation down.

Comment

I don't understand how you guys can shut down an institution like this that has been around for 74 years. These ponies are well taken care of and you would see that if you went there and took your family. My father used to go, my parents took me and my sisters when I was a child, it is nothing but joyous memories. Memories that I'd like to make with my own daughter who is now almost two. We took her there the other day. They are closing early now because they have sold off most of the ponies and cannot give them to bough breaks to take on all of the children wanting to ride them. That itself shows you they care for the ponies. While we were there we saw them switching them out. Fresh water, lots of love and pets. PLEASE consider renewing. The amount of joy this place brings to everyone I've spoken to and how their eyes light up with memories of it. We need somewhere like this, affordable places for children to learn and be able to experience ponies. Set guidelines, make up any rules you need to. But please save the pony rides. This place should be a landmark.

These ponies are being well-kept, cared for, have jobs, and in their own herd while also getting so teach young children about how to love, ride and care for an animal. The pony rides additionally provide jobs to Angelinos and an amazing, affordable and local activity for families from all walks of life. My daughter has been riding these ponies since her 2nd birthday and knows all their names. She is now 4.5 and sobbing her eyes out worried that the ponies will forget her and that she will never be able to see them again. These ponies are in the only home they've known and it is a tragedy that this park is being closed. We are disappointed in the lack of transparency and notice that this is happening. Save our ponies.

The pony rides, much like the carousel and other features are calling cards of the Griffith Park area and it's a shame that the history of the are as being a family outdoor experience center has been closing. Building a love of the outdoors takes time and habit for a family and removing these attractions, while they are being run ethically, is sad for the community and a poor reflection on the LA Parks and Rec. Perform due diligence, and make the decision—don't just cower to false complaints because they're annoying. Those who seek to harm vs bring community and fun to our city should not hold more power than the voices who want to see our parks system active and thriving. Please reconsider closing the pony rides and evaluate other closures.

Shame on you city of Los angeles

This is a service to our city. Much needed specially for low income families.

Keep them for the kids

Save the ponny ride

We had a birthday party for my son at the pony rides and we offered the kids/guests a ride. For some it was the first time and they loved it. The ponies look healthy and well fed and they bring smiles on children's faces

These pony's have been well taken care of for over 70 years. The best interest of the pony's is to remain where they are as the pony's would go through trauma leaving their loving home.

Please leave the pony rides and petting zoo alone! They are essential to our community and have been for decades. One of the last remaining authentic opportunities for children of Los Angeles to connect with nature and the wonderful animals. It would be tragic to have them disappear!!!

Horses and ponies look to please their owners, love bonding with us as their herd leader, need other equine buddies, are known to make lifelong attachments with other horses and people; and appreciate having purpose. Having resources for children such as the pony rides and petting zoo are a safe introductory to animals and agriculture that often city bound children will not see or experience otherwise. Animals teach us so many important lessons; teamwork, leadership, caretaking, confidence, unlimited love and acceptance; and even life cycles and so much more. These pony ride and petting zoo animals already met regulation and welfare checks (which include breaks, shelter, feed needs, time off, etc); are under regular veterinarian and farrier care, and are well cared for, even having a misting/cooling system (goes above requirements). They are in good weight, have good attitudes and personalities, and are well trained and adjusted. The owner has been open, honest, and forthcoming with his dealings with the city, and obviously has the animals' well-being at heart based on his interviews. I am confused about why when all standards are met, when government agencies are stating in compliance, that there is a question about renewal (I thought there was a document with a 2023 renewal date?); simply because a loud and foul mouthed, poorly educated and emotionally driven woman can prance around debasing herself with harassment of children, ponies, and the public while misusing her political connections. For shame.

We as a culture need more exposure to animals and educated agriculture and the benefits they bring; not less. Listening to the activists who are driven by emotions, ulterior motives and misinformation/outright lies is going to reduce the agriculture opportunities and incomes (for the farmer and the states/nation); weaken our food infrastructures and agritourism, and lessen the connection we have with this earth and it's inhabitants because we have less interaction and correct education. Personally, I surmise that we will have more social injustice because we as a people will have less connection to animals and their lessons during our young formative years. Enough cancel culture; common sense needs to prevail.

From my experience I have seen the staf as well as parents as a wonderful crosssection of America and anyone who has a problem with the pony rides I'd like to cross examine. I loved what I saw it brings tears to my eyes.

Save the pony rides

Don't let non equestrians make decisions about the horses well being

These ponies bring so much happiness to the kids and everyone that comes to see them. Keep the pony rides!!!!

Don't let a small group of uneducated protestors shut down the pony rides

I'm distraught at the fact that the ponies won't be around for my future children. I have been going to the horses since I was 4 yrs old and it has been the fondest memories of my childhood. Please don't take this away from all the children and families who enjoy these ponies without evidence of abuse or wrong doing.

I have been taking my kids for the past seven years and I pictured taking my 6 month old when he got older. It's really disappointing to think that I won't be able to if it closes.

I believe that closing the pony rides is completely wrong. The evidence provided to support the decision is incomplete and biased. At the very least there should be a few fully independent equine specialists who reviewed the business to determine if the concerns were warranted. Instead it appears that the patrons and guests of the park have been allowed to be harassed and maligned by the protestors without any protections. It appears that regardless of the equine standards and facts the decision was based on placating the protestors instead of in the best interest of the ponies. It also appears that there may be undisclosed reasons for this business to be closed, so you can bet that if they get closed the park will be under very close scrutiny to make sure that the decision was ethical and not based upon any personal gains. This decision is destroying the business and lives of these ponies, please extend the closing date until proper and unbiased investigations can occur. And lastly, please start protecting the children who use Griffith Park from the harassment they face from the protestors.

We wish to keep the pony rides open

This has been a family friendly location for decades please save our family tradition

As a child I would come here it's a shame my daughter won't be able to come.

I came as a child and now I want to my daughter to enjoy it. Loved the ponies growing up

We love the pony rides. My children have had so much joy being exposed to these beautiful animals

Save the ponies rides at GP

Keep the ponies open!!!

Please keep the pony ride, my kid loves it.

I want to keep the ponny rides

Save the ponies!!!!

My family loves the pony rides at Griffith park. There are not many places left for wholesome fun for kids that are reasonably priced. My girls love riding the ponies. Please reconsider closing this part of so many childhoods for so many years.

Thank you

Sheena

Save the ponies!!!!

Keep the pony rides open

Comment

Please keep them open

Please keep them open

Please keep them open

I WANT TO KEEP THE PONY RIDES. THERE ARE BIGGER ISSUES AND THE PONIES ARE TAKEN CARE OF .

I want to keep the pony rides.

Save the ponies!

Please save this caring institution!!!

My kids and grandkids Emilio the festivities at Griffith park... please reconsider on this shut down...

We love ponies

Save the pony rides

Save the pony rides

Please save the pony rides, children love this opportunity!!!!

Keep the ponys

I was saddened to learn of the imminent closure of the Griffith Park Pony Rides. Though I have no children, I used to jog in Griffith Park regularly, and was always cheered by the sight of families enjoying the rides.

I am sure most of the thousands who visit the pony rides would not do so if they believed the animals were being mistreated. While there may be cause to look more carefully at the operation of the pony rides following the deaths of a few of the animals, from what I have heard, it sounds like nothing serious has emerged regarding the ponies' living/working conditions. In the absence of such evidence, the city's decision to close this 70+ year attraction with little public input seems arbitrary if not cowardly.

I do not know these protesters but would guess that for some, no use of animals by humans would be acceptable to them. If that is also the position of city officials, it would put them at odds with most of their constituents.

I hope the city of Los Angeles reconsiders its decision and allows the pony rides and petting zoo to continue (if not with this contractor, then with another).

Yes

Keep the ponies rides open

Save the pony rides

Please keep the pony rides! It's what the original owners wanted. This was shut down by a small group of very loud activists who don't think ponies should be ridden at all. Please stop letting the loudest people get their way! My daughter makes a living taking care of horses and it has been her lifelong passion. Her first exposure was a pony ride at a street carnival when she was 3. She has been in love ever since. Please allow other kids the same opportunity.

The pony ride attraction at Griffith Park is part of Los Angeles' iconic and diverse history. Shutting it down is the beginning of the end to all forms of equestrian life and enjoyment in this and other areas. Wiping out a lifestyle for the many have worked so hard to keep alive. Further, the impact on the ponies themselves who have lived as a herd for decades is unconscionable. The ponies were found to be in good health treated very well. I WANT TO KNOW WHY THIS IS HAPPENING?!

The animals are very beloved and ponies are meant to be ridden. I have come here since I was a child and have fond memories and my daughter does too. I would love to bring the next generation

Griffith pony is La history need to keep it alive

Pony rides are not hurting anyone but bring joy to children of all ages

Please keep pony rides

Keep the pony rides !

Keep the Pony Rides a lot of memories made here !

Keep the Pony ride open at Griffith Park

Please save the pony rides. It's important for the equestrian community and for future generations of our city.

Please preserve the pony ride! Kids deserve a chance to enjoy horses!

They ruined an incredible experience for children and families.

Animals die like humans they pass when it's time. They have a life cycle.

How do the Animal rights activists know they were not given water? there is no evidence to back that up.

Don't tear the place down, or, make it a MUSEUM at least!! And don't put a Starbucks!! Thank you.

Please keep the pony rides in place. The ponies are used to their herd where they live and retire. The children of LA need this community resource.

I am in support of keeping the pony rides open. The allegations of abuse were unfounded and after multiple vet inspections the ponies were found to be in good health. This is a popular attraction and gives children of all financial means to have positive interactions with ponies. Many area equestrians got their start riding those ponies. The decision to close the pony rides is not in the best interest of the children, the ponies or the city of Los Angeles.

Please keep the pony rides. It's one of the few affordable activities we can do with kids. My oldest loves the ponies and loves being able to touch them and pat them. Please consider renewing their lease. This will be sorely missed.

These pony rides are an essential way to expose so many people to the love of horses and and gain an appreciation for them. Many of those exposed here have gone on to love, appreciate, and care for horses throughout their lives. Don't take away the chance for people to find this love in their lives and the lives of so many horses!!

Closing the pony rides is a huge loss. Outdoor recreation and being around companion animals are two ways that we can combat the growing mental health problems with young children. Griffith Park Pony Rides provide families access to both outdoor recreation and ponies that most families can scarce afford with rising cost of living here in California. A pragmatic measured approach already involves ample safety measures, and requirements to make sure ponies are well taken care of. Please let our children be children and experience the joy and therapy of interacting with ponies - so deeply ingrained to our heritage. Save the Griffith park pony rides.

So many memories made here that will be denied to future generations for no good reason. There has been no valid proof of animal cruelty.

Comment

Please reconsider the Griffith Park Pony Rides concession contract.

I am very concerned that the City of Los Angeles caved to a small group of very loud, paid for professional protesters and decided not to renew the Pony Rides contract. These protesters had no problem using curse words and vulgar gestures in front of tiny children and verbally assaulting the parents who brought their children to the pony rides to enjoy some close contact with animals. In addition, the leaders of the protests posted and spread outright lies about the pony ride operator - and left death threats on his phone voicemail.

Are these the people you want to support?

As a lifelong equestrian, I am always concerned with the welfare of all equines - and I think that the ponies are in very good hands. Mr. Weeks retires ponies that can no longer work - and supports them until they expire. He does this with ponies one at a time - no one can retire and support 60+ ponies all at once. The ponies have a job - which provides them with much needed exercise and helps defray the cost of keeping them. If they were all just "sent out to pasture" they would suffer health issues from lack of exercise and free feeding. The ponies are of good weight and they move soundly. "Making them work" actually keeps them healthy. They get regular veterinary care. Mr. Weeks even sent one to the hospital when it was ill. This is extremely expensive. Does that sound like someone who doesn't care about animal welfare and is just doing this for the money. No. And believe me, he is not making much money on \$5 pony rides - hay, labor and other expenses have gone up nearly 200% in the last few years.

Please renew Steve Weeks contract for The Griffith Park Pony Rides.

Dear City of Los Angeles Dept of Parks and Recreation,

As is the case for so many area residents, the Griffith Park Pony Rides were an important and beloved part of my childhood, as they were for my mother before me. The pony rides allow children from modest households to interact with horses, providing opportunities otherwise out of their reach. For myself, the rides contributed to my becoming a California Registered Veterinary Technician, a career I have held for forty years.

Not every child will pursue a career in veterinary medicine, but it has been proven that interaction with animals increases a child's sensitivity to others, leading to a higher emotional intelligence, higher empathy for people and higher empathy for animals. For horses in particular there is the saying, "The outside of a horse is good for the inside of a (person)."

As part of my long career in veterinary medicine I was the Hospital Manager for the Oregon Humane Society, a large and progressive animal welfare organization, of which there are many similar organizations in California. Like all true animal welfare organizations, OHS has a well developed Education and Outreach Department focused on children's education. Animal welfare organizations know that the more children have interactions with animals, the more empathetic they are to them and the better they will treat them when adults.

In contrast to animal welfare organizations, animal rights groups do not provide care for animals. They have no shelters, no rescues, no foster homes, no solutions. They do not value the human-animal bond that is at the heart of veterinary medicine and in the heart of animal lovers everywhere. Some of the largest animal rights groups do not believe that people should have companion animals and would be very happy to take the pet you hold so dear from you. Animal rights groups main accomplishment is manufactured outrage, not animal care.

If you think you have escaped the animal rights activists' fury and protests at your homes by caving to their demands, you are mistaken. These groups now know that their guerrilla tactics will frighten you into concession.

Children become better caretakers of animals by being around animals, not by being separated from them. If you care about the welfare of animals, you will reverse your decision regarding the Griffith Park Pony Rides while there is still time. By allowing a great tradition of the Los Angeles community to continue, you will contribute to improving animal welfare in our community now and for the future.

When I grew up in the SFV in the 60's & 70's there were horses everywhere we could ride. Riding a horse shouldn't be just for the rich and privileged now. Please keep this facility for all families.

This is absolutely devastating news: the pony rides have brought such joy to children for decades- there are so few places (if any) that children can ride, touch and be exposed to ponies/ horses. Horses are an integral part of our history, and the pony rides are a wonderful opportunity for children to be introduced to these amazing animals. There's nothing like the bond between a child and a pony: Many equestrian athletes discovered their passion for riding, from that early experience sitting on the back of a pony. Please don't take that experience away from countless children for generations to come. This will just crush the dreams of the children in our community. And what will happen to these ponies?? Please save the pony rides!

I would like to address this comment to Matthew Rudnick.

Matthew, to be clear, these are not Steve's words. They are mine as his wife and someone who has been an integral part of this nightmare of the last 15 months. After staring at the sad faces of children all day today with protesters cursing at them, I felt compelled to address my comments to you directly.

Matthew, you were our partner. The countless conversations that we have had with you over the past year are imbedded in my head. You experienced the same wrath that we did with this angry group of protesters. To have these people invade the personal space of our homes was unimaginable.

And yet, they have won this battle. Where were you when all of this was happening? Where were you when a motion was made to cancel our contract? Where were you in standing up for right and wrong? Where were you in standing up to your boss and standing up for us? You know more than anyone what we and the families of LA have endured over the past year. You also know that Steve did NOTHING wrong. The lame excuse of lack of transparency as an excuse to cancel our contract is unbelievable. And believe me, people are seeing right through that.

The anger that I feel towards you, your boss, and the City Council of the city that I was born and raised in is overwhelming.

I feel personally betrayed by you. You knew the truth. In the end, you were not forthcoming with us. While Steve and I will move onto the next chapter in our lives with a clear conscience, you will be reminded daily of your actions.

Copyright ©

Please don't let this happen. Please don't erase anymore Los Angeles history.

Comment

I had my first pony ride at Griffith Park pony rides and 1956. And I was hooked. Lived in breathe horses from then on.. Graduated North Hollywood high school with an agricultural scholarship started doing pony rides part-time in 19 77 x 19 83 and it turned into a full-time business. Hank Bronk and his family, who then operate at the Griffith Park pony ride, helps me up in a pony ride like Griffith Park in 1989 and I remade there until the end of 2002. So much joy the Ponies brought, and even to the parents. We had a whole crew of children who would come on Fridays after school or Saturdays as a reward for getting all their schoolwork done A's on spelling test, whatever. Public pony ride is where a low income family can come and have this experience. Thousands of families will never be able to afford for their children to ride ponies /horses.again if goes away. I still own horses and ponies, and I do know a great deal about them. We horse owners will say to ourselves in the summer why did they go out and lay in the hot sun when they could be in the shade? Why do I have this beautiful barn with a nice soft betting that my horse can go in and out of and they go and stand out in the rain? Someone just send me a photo of their horse standing out in the snow and said I built this beautiful barn. He has a warm stall , lots of straw to lay on and even heated water and he's out standing in the snow.? Why? Because they are horses. The horse is considered a prairie animal. I see mustangs in Nevada year-round out in the weather and they don't seem to mind. In fact, mustang travels 25 miles every day and it's quest for food and usually goes to water once every 24 hours. As for for Ponies, dying in a short period of time that happens, horses are prone to a stomach disorder called colic. And it's all lumped together. There are at least a dozen causes, including a simple change in the barometric pressure in the air. I lost my best horse in March at age 28. He was playing outside over the fence at 1 PM in the afternoon by 2:20 PM. He was down curled up in a ball. He receive pain medication right away and an emergency vet out. Horse was treated and 20 minutes later went right back down again. Another emergency call to the vet and I learned that he needed to be euthanized just like that.. I am told they don't feel that he was transparent and reporting the four deaths. I have also learned that it is not required in his lease that he do that. Any horse veterinarian will tell you that in spite of our very best efforts sometimes they just die anyway. Mr. weeks has taken far better care of these animals than most of the horses or ponies in my neighborhood.

When DW Griffith deeded this land to the city of Los Angeles. It was with the understanding that it remain for horses. Please don't take away the only opportunity that our children Especially our low income children will have. I meant parents there today from Compton , Baldwin Park ,Fontana.and Inglewood. They drove great distances to give their children this experience.

Please don't shut down the pony rides. I have had three generations enjoy the pony rides. I have been an equestrian over 50 years. What I have witnessed at the pony rides is children joyful to have a ride and pet the pony. Out of all the historical changes in our world why remove the smile from these children. I pray that the activists that think it is cruel to love on ponies don't cause harm to our officials personal space and pressure them to take this wonderful landmark away.

I urge you to reconsider the misguided decision and to renew the pony ride concession contract. You're setting a horrible precedent by giving in to the uninformed extremists. This will only embolden them to keep harassing people to get their way.

You know the ponies were well cared for, as verified by the veterinarians, and the ponies that passed away died from normal causes, not abuse or neglect.

The pony rides are one of the only opportunities for LA children to spend time with and ride horses at an affordable price. The love and compassion for animals that is fostered by this interaction can't be replicated.

At the least this must continue to be a venue where small children can interact with animals. The model for that interaction can be changed, but the invaluable ability for children to interact with animals must remain.

My name is Kelly Summer. I support the Griffith Park Pony Rides. I strongly oppose the closure of this business.

They treat the animals with the utmost care. Don't be fooled by people who don't know about horses ponies or animals.

Don't be part of the lack of recreation in this new world society. Shame you're letting cry babies with an extreme agenda win your fight. Pony rides are a vital part of a child's experience with nature.

I know, the park department could have a place where children can ride ponies at Griffith Park. well done taking away something nice.

A greater rescue problem has just been created by closing down the rides. How is it humane to suddenly unhouse well cared for ponies? I'm a horsewoman and I feel the owner has been unjustly targeted after caring so well for his animals, now being forced to auction. Most of the time, auctioned ponies = slaughter. I'm against the closure!

Hi my name is savannah ross I am 20 years old and I would like to say that taking away the Griffith park pony rides would be taking away a tradition. These pony rides have been around way before me and they should continue to serve the Los Angeles area for future generations, I first started visiting the pony parks at 3 years old and it sparked my love for horseback riding and showed me a true appreciation for horses and animals as I grew up. The pony rides are a vital part to the Griffith park area and a staple attraction, by shutting down the pony rides underprivileged families and underserved families won't have access to farm animals or let alone have their kids ride a pony so close in the city at the price it is at the pony rides. These animal activist know nothing about horses and their mindsets and how they function as animals. They even admitted to being payed to be there with no real purpose of actually having a cause to be there. Please consider keeping the ping rides open for future generations. It would mean the most to the community and to Steve weeks who takes amazing care of his animals.

Our family is deeply saddened to hear about the closing of the pony rides. My sisters and I grew up going there and it's very sad to know that we won't be able to take our kids there. There are so few opportunities in a big city to see and interact with real animals and nature, and now there is one less resource for the children of Los Angeles. The affordability of the attraction was a big factor too for us working class families. LA is often ridiculed as a city without a history and it's such a shame that the department of parks and recreation have decided that an important part of LA history has no value.

Ponies stay very comfortable and trainers are very take care of ponies well.

Please keep the pony rides in Griffith park. My kids are disappointed to learn the city wants them shut down. Let's find a solution to this that involves keeping the rides while addressing the concerns both in support and those opposed to it. I know we can do better.

Please keep the pony rides and petting zoo open!! These city treasures help give kids and adults a chance to LOVE animals, not just to see them after they have been made into corporate logos or meat.

If the goal is really "animal rights" rather than cost-cutting, PETA should focus on the literally billions of animals kept in breathtakingly horrific conditions.

Seriously after 74 years, please keep it going for all future children.

I was fortunate to grow up with horses and ponys and not everyone is so privileged as I was.

For all I know, maybe there are reasons I am not informed of re: closing this down. However, it is not clear, and that is a problem. So I want to know the following:

*Why wasn't this brought to a public vote?

· Did Jimmy Kim violate the Brown Act (governmental transparency) by refusing to respond to concerned local equestrians who reached out to him?

· Why did the councilmembers claim that protestors outside their homes didn't affect their decision-making, then rush through the Oct 25th motion, which was then followed by Jimmy Kim's November 23 letter to Steve Weeks informing him of their decision?

· Why did the councilmembers and Jimmy Kim ignore the findings of the independent third-party veterinarian who monitored the pony rides for one year, finding that they were in full compliance?

· Who benefits from the lease expiring and this land becoming available?

I am concerned and feel this whole situation needs to be looked into by impartial individuals. What is all the reasonings?

Thank you,

Please keep the pony rides at Griffith Park. The kids love them the parents love them their workers love them and the ponies love to have a drive. It's a historic place and a tradition for so many people!

Comment

This is such a sad thing! Those ponies and their owner do not deserve this! There should have been more input from the general public instead of just what some radical protesters think!

You have messed up a good thing. Still trying to figure out why you have taken one of the best features of the park. I have a great idea, why don't you bring back ponies so that kids in the city get their one and maybe only chance to ride a horse/pony.

Comment

Hello,

I have written to you already voicing my anger at the egregious manner by which the Griffith Park Pony Rides were shut down. You are now soliciting ideas for "reimagining" the venue. I think you need look no further than the recommendations of Dr Rachael Sachar DVM, CVA, the veterinarian hired by the city. In the conclusion her final report she stated

"I suggest there be additional discussions, provisions, and modifications to expand the concession's potential use beyond its current value as a recreational activity and/or place of entertainment. It would be of greater value to the community for the concession to incorporate educational opportunities to the public and collaborate with existing community programs to ensure that it continues to be a viable and sustainable concession and feature for Los Angeles and surrounding communities as well as an important attraction and recreational activity for its residents." This sentiment was echoed by Dr Ramey DVM and President of the Los Angeles Equine Advisory Board who wrote in strong support of keeping a pony ride concession in Griffith Park.

Dr Sachar in her first report says that she was asked to research policies for working animals in other cities which she said was beyond the scope of her initial contract with RAP. She also noted that she has worked with sanctuaries and animals in film and TV that are under intense scrutiny by the most extreme animal rights advocates. They voluntarily follow more intense guidelines. She recommends that Griffith Park Pony Rides do the same. To me this is the win/win answer. The current, mostly older ponies have all gone to good homes, the more reasonable protesters can claim a victory. The most extreme protesters who hold that riding a horse, in and of itself, is a form of abuse, as well as those who continue to attack Mr Weeks personally should have no place in this discussion. We should start again with new ponies and far stricter guidelines and regulations, as well as educational components. No one supports animal abuse, but the vast majority of people do not believe that riding a horse is abusive. If we allow the pony rides to be shut down we embolden Ms Fahim and LAAA to go after other horse related venues. What's next, trail rides, and Griffith Park Mounted Rangers? The LA mounted police horses? What about the Rose Parade? And how do we justify holding the Olympics in Los Angeles if we are not an equestrian friendly city?

Lastly there is Sec. 595 b) Lease of Facilities from the Los Angeles Charter Recreation and Parks Department. I'm not a lawyer, but if this is still current and means what I think it means, then the venue can only be leased as a pony ride.

Thank you so much for taking the time to read this,

~~XXXXXXXXXX~~

Sec. 595. Lease of Facilities.

The Board of Recreation and Park Commissioners may lease for recreational purposes any municipal auditoriums, arenas, sports centers or related facilities subject to the following conditions:

- (a) The term of the lease shall not exceed 35 years. Leases in excess of five years shall be approved by the Council by ordinance.
- (b) The public must be entitled to use and enjoy the property or facility for the purposes for which it was acquired, constructed or completed and any lease shall require the lessee to operate the property or facility so as to furnish the public with that use and enjoyment.
- (c) The board may enter into the lease without inviting bids and may prescribe other terms and conditions as it deems appropriate. First of all thank you for finally allowing public comment on this issue. Losing the Griffith Park Pony Rides, and the way this has been handled upsets me on so many levels. I am a 24 year resident of Los Feliz. When my daughter was little we regularly took her to the Pony Rides, the Train, Travel Town and Shane's Inspirations. Of all of these the Pony Rides were the greatest equalizer, offering a place where city kids from all walks of life and all economic levels could easily give their child the opportunity to ride a pony. Playgrounds and train rides are available inexpensively elsewhere, pony rides are not.

The first thing that upset me was the fact that by the time I heard about this (an LA Times article) it appeared to be a done deal. What I read claimed that the lease had not been renewed because of lack of transparency. That seemed particularly hypocritical considering that there had been no avenue for public comment. Then the claim was made that the lease was not renewed because four ponies had died. But all one had to do was read the third party vet report to learn that reporting the deaths was not required, and they were all retired ponies, none of them died under suspicious circumstances, and that one of them lived into its late 30s. That's comparable to a person living to over 100, a ripe old age that only well cared for ponies reach. After that the reason for declining to re-sign the lease became poor record keeping. That's no reason to shut down a 74 year old much loved historic Los Angeles venue. It sounds suspiciously like someone has an agenda and someone is trying to justify it in anyway you can.

The second thing that upset me was that the public was allowed to believe that these ponies were abused, when nothing could be further from the truth. Your own third party vet report found no abuse. Any suggested improvements to the ponies way of life were made by Mr Weeks who worked in good faith with veterinarians and RAP. I have a friend who has owned horses for over twenty years, at one point during the past year she had gone down to the pony rides expecting to find horrible abuse and found plump healthy ponies, with good teeth and hooves that were well cared for. Any recommendations made by the vet were followed. The ponies do not work in the rain or excessively hot weather, they walk in a circle for short shifts with a small child on their backs. They need to be exercised much as many of us walk on treadmills. It is also troubling that the City's Equestrian Council, and the large equestrian community were not included in this decision.

The third thing that upsets me is that a small group of fanatical "animal rights" protesters have been allowed to ruin something that continues to bring joy to masses of families in Los Angeles. Unfortunately this type of thing is becoming more and more common in the world today. Tiny, vocal extremist groups get to make decisions for the far larger, far more reasonable majority. I know that you all claim that their protests had nothing to do with decision, but your quoted reasons don't actually stand up. I have seen, and heard these protesters. This is not the Women's March where hundreds of thousands of peaceful protesters filled the streets, kindly, respectfully, and joyously. These people are abusive. I have seen them curse at small children, and make them cry with absolutely no remorse. If Los Angeles gives in to these people and shuts down the largest Pony Ride facility in the U.S. we are opening the door to the normalization of yet more dangerous extremist ideology. They find no distinction between use and abuse. They ARE NOT THE SAME THING. They equate the use of a well cared for working animal with slavery, It IS NOT THE SAME THING.

You are looking for suggestions for rethinking the land where the Pony Rides are. I believe the pony rides should stay there. I have heard that the lease agreement might even stipulate that a venue stay as what it was originally built to be. Follow the suggestions made in the conclusion of your own third party vet report. Add more educational aspects to the existing pony rides, open up the sanctuary portion of the pony rides to the public. Several of the more reasonable callers to your zoom meeting named existing sanctuaries such as Kindred Spirit. Partner with them or model the sanctuary portion after them. That will be a compromise with the more reasonable protesters. Please do not consider go carts or automated venues. Someone suggested a roller rink. Moonlight Rollerway is right across the freeway on San Fernando Road. I believe they are a family owned business, please don't compete with them. Griffith Park is a haven of peace and quiet, a magnificent piece of the natural world in the second most populous city in the U.S. Up until a few days ago even had a resident celebrity Puma. I appreciate your decision to include the Equestrian Council and the LA Historic Commission as well. Griffith park is a great gem in our city, please keep the Griffith Park Pony Rides and work with Mr Weeks to make them an even greater asset to Los Angeles than the already are.. Hello, I listened to the December 15th meeting for a second time. I would like to thank Commissioner Nicole Chase. At last someone has realized that the Equestrian Commission and community should have a voice in any decision about keeping the Griffith Park Pony Rides. It is of course a bit late. The December 15th meeting was already too late for the community at large to have a voice in whether or not we wanted the pony rides shut down. So much for representative democracy. The only voices that apparently mattered to Ms Raman and Mr Kim were those of a fringe group of animal rights activists who equate riding a horse with abuse. None of us support animal abuse, but the vast majority of people do not consider riding a horse to be abusive. I shouldn't need to point out that the advice of the third party veterinarian that the city actually hired as an expert was also ignored. Dr Sachar visited the pony rides three times over the course of a year. She made suggestions for improvements that she PRAISED Mr Weeks for following. She advised the city council to RENEW the contract. Earlier meetings which might have given the community at large, and I speak here as a resident of Los Feliz Council District 4, a chance to voice their opinions were canceled. One can hardly blame many of us for thinking that 'the fix was in', something fishy was going on, and that a deal had already been struck behind closed doors. I am concerned with Commissioner Ramey's statements that despite there being no REQUIREMENT for Mr Weeks to let the city know about the deaths of four retired ponies, he should

Comment

I heard there were specific conditions when the Griffith family gave this property to the city. One was about having horses for children to ride. This sounds like the only angle to back off the city.

For urban areas like ours, there is limited access to nature and animals. How will kids discover their love of animals, like horses if they don't have access to a 5 minute pony ride. The future is grim. Kids are on screens all the time. There are no opportunities to interact with animals. The future looks horrible.

This is such a class issue. If you take this away from the lower and middle class, the only people who have access to horses are wealthy individuals.

If the conditions were truly awful, allow the business to improve conditions. A community GoFundme can help raise funds for better conditions.

Closing down the pony rides serves no one but a small tyrannical group. It would be great to see the city leaders be part of solutions for the communities they serve and not just bow down to a tiny minority.

I cannot believe you are doing this to our City and our park. This is exactly the kind of activity the park was slated to have for the community! The pony rides are an opportunity for all children to interact with animals at an affordable price and brings much joy to the community. Those ponies are very well taken care of which has been evidenced time and again by the owner. Shame on you for caving to special interests who would rather take the park in another direction other than that for which it was meant! Keep our pony rides for health and happiness of our children, our park and our city!

To all on the LA City Council Board---Parks And Recs--

I am appalled at the shutting down of the Pony Rides in Griffith Park.

I am a tax paying horse owner here in LA area. I have owned horses , had them in my life from a super young age. You who have zero experience with horses period, listening to over radical people Alliance for Animals to make choices for LA. It is so sad that you have allowed these lunatic people to win this battle that they have promoted, for no reason. I have read the vet reports front to back....there was not anything worthy of being concerned , especially to this level....PLUS--some of the reports were to be expected of ponies that are that age. PLUS what could be taken care of/fixed has been....So explain why the contract is not being renewed???? They are part of the historical vibe of Griffith Park, along with promoting a family activity to share with kids. You talk about all the crime, drugs etc in LA, especially with youth....and yet you take away a family activity?? When children are exposed to horses-ponies at a young age , they can develop a long lived pure passion for the love of a horse in their life. Many many young people have been kept active with stronger moral values, learning values-responsibility from horses. You should be doing what you can to keep them in business, NOT shutting them down.

If any improvements need to be made---it is YOU understanding the value pony-horse riding adds to a life long responsibility that a child can learn from, for their future values.

Have you watched the videos of the nut jobs that you are allowing to sway your decisions?? OMG....Believe me--there are so many horse lovers/owners in this immediate community---and especially around Griffith Park itself....that tons of horse riders ride in , and go by every day/week....If horses/ponies are being mistreated-truly abused everyone in this Equine community would speak out AGAINST it....But don't take the words from people who have no clue what is considered abusive with Equines.

Protestors saying the ponies "looked" sad....My horse lives in a wonderfully clean stall, has fans, misters, exercise rider I pay, person I pay to turn out every day, blankets laundered, blankets on/off as weather changes, premium hay, grains....Gets his butt wiped, literally every day....awesome hay /treats to eat....But I can send you any day of the week/ a "random" picture where you can "portray " him looking "sad".....Its probably cause his owner(me) hasn't gotten there yet, or he wants another "treat"....Dont buy into this garbage they are spewing to you....truly.

Wow---as they say...read between the lines....these are paid protestors...they look like porn stars, or people with anger mental issues.....Stop this nonsense now....

Think about this....truly....

As I stated....I am appalled....that you are even considering this....

The City needs to reverse this ruling, and be helping Steve Weeks or anyone else that will take on the Pony Rides to stay in Griffith Park....for its kids, youth, families and LA.

Your treating this business like they had a dog fighting ring going on....Those ponies are fine, they are cared for....and loved by tons of kids.

DO not take the words of people who do not have any authority knowledge of horses-ponies....The real people who have knowledge are so very disappointed -outraged in your ruling.

~~From Facebook~~

Burbank

Property owner/horse owner/tax paying citizen/raised 2 incredible children-both college graduates..I am appalled and disappointed with the COUNCIL and PARKS REC for this decision. I want to know WHY Steve Weeks was closed with no public hearing prior to any vote of this? I want to know WHY it was decided by NO vote taken from entire COUNCIL. ? I want to know WHY the LA Equine Council was NOT consulted on any of this?? I want to know WHY YOU state reason for closing is due to his transparency on showing 4 ponies passed away when in his contract it does NOT state, and YOU have admitted this also for him to state that?? The vet has shown that their was zero suspicious about any of the deaths!!!! I want to know WHY the entire COUNCIL and PARKS AND REC have let these crazy over the top Animal Activist protest at his business for almost entire year, in there crazy lunatic manner....with CHILDREN FAMILIES present every every time????? Something is not in order here.....this should never have happened....I want to know WHY it states I the Griffith Park by law exchange that a PONY ride has rites to be maintained on GRIFFITH Park property and YOU are closing it?????The reasons YOU have used are pathetic, and truly a cop out....There is something not right with this story....I propose you change the ruling NOW....I can NOT believe you are doing this....Whats the real story here?? It will unfold.... because this can't possibly be the reason for closing this 75 year business that was running just fine till some ludicrous crazies protestors came in that believe just riding a horse pony alone is reason to file abuse charges.....You all need to listen to the horse knowledge community...We run a tight group....if there was any concerns we would already have known about it!!!! We don't need some nut cases to come in and tell us about the skeletal muscular vertebrae on a horse, nor that horse don't even carry their young on their own backs, nor any use of animals is abuse.....or the spot needs a no animal model put there.....Really?? Then what about the LA ZOO....what about ALL the horse riders daily in Griffith Park.... what about the Mounted Police.....what about the Park Rangers that ride thru the park via horseback....This is insane...Take the words of knowledgeable people.....equine owners/riders/veterinarians/the Equine advisory committee.Go back and erase what you have done immediately.I would like answers.....as to WHY the protestors were allowed to shut this business down? I would like to know WHY they were allowed to even be on property for an entire year. I have been there the last 2 week ends, they are atrocious, screaming yelling profanes at family, kids, grandparents.....Crazy....Unacceptable from the City.I would like to know WHY the formality protocols have not been followed as to investigating this business, meetings, voting, public discussions, equine board consulted?? I would like to know WHY you are not taking the opinions-knowledge of vets , equestrians, that have tons of knowledge about horses-ponies?? This should NEVER have been done to the City lower income families that access the Pony Rides Every week-end.... What is the real proposed use for this property, something seems very very questionable in this entire process. I as a tax paying, property owner in area, equestrian owner, horse rider, user weekly of Griffith Park...Would like my opinion to matter. The last meeting you had with the Task Force was a waste of time. You had already decided this business's fate. You only had that meeting to appease us that we were "heard".....We were heard our voices, BUT not listened to at all. Out voices with tons of knowledge and opinions, mattered zero....I am so disappointed and appalled in this being done to Steve Weeks.....This needs to be reversed asap.

More than concerned LA resident--I spent 7 hours on this past Sunday protesting on be half of Steve Weeks and showing support to the public FOR the Pony Rides to stay. The protestors that are against the Pony Rides are an embarrassment to the City. They are paid protestors from not even in LA area. They are over the top activists...Very sad to see them scream the F word repeatedly at family-kids-grandparents--LAPD officers....And you want to believe anything these people support?? Their leader Zohra Fahim 's character is horrendous. Google her name...her own family has a court order against her....She was arrested on property at Pony Rides for threatening to hit a pregnant lady....The general census of everyone, not just a few....everyone I spoke to at the Pony rides said they wouldn't believe not support ANYTHING that crowd was supporting. They felt they were over the top with the mob mentality motions presented to the public. You yourself now they have threatened Steve Weeks family and went to the actual home of Jimmy Kim....

You need to watch all the videos of the protests from this past year...Unbelievable out of our City Council and Parks and Recs.....

You are as appalling as they are by siding with them in any shape or form....

Jimmy Kim has made huge mistakes in his choices, maybe he should be terminated--not Steve Weeks....

Comment

So much to say. What has happened to the Griffith Park Pony Rides is such a sad situation. From everything I've heard, the decision was made without public comment, and with the opinion of the activists only. I have been a horse owner since 2001. I am responsible and certainly an animal lover. The ponies have been well taken care of, but our city's government is not. Please look at your decision again, and reverse it. Thank you for your consideration.

I rode the ponies as a boy. We did not have much money but it was affordable. I am thrilled to see it is still affordable and struggling families can participate. The ponies also still continue to be humanely treated, I understand the vocal few that are trying to shut down the pony rides oppose pony rides of any type at all, despite the proven humane treatment. Please beware of unsubstantiated claims about the ponies.

I think they need to continue with the pony rides. Kids who have no experience with animals for a short time get to experience the pleasure from riding an animal. It is great for the kids

Please keep the pony rides at Griffith Park !

I would like for the Griffith park pony rides to be open i would come here as a young child now im bringing my kids to the park i would be sad to see it go away

I'm sad you're going to close down the pony rides. I've been going to the pony rides since I was 5 I'm currently 33 years old. I started taking my kids here since they were babies. They love coming here the rides are affordable the kids have fun. Please don't close it down?!

Closing the pony rides and bending to the will of protesters are wrong. The parks department/city of LA should be working with the owner to fix problems or concerns rather than just ending a 74 year old institution. There are so many ways of working with the pony rides to maintain operations.

I have been an equestrian for 20+ years , and I can rest assured that these ponies have been cared for and been taken care of . These ponies are happy , and relaxed . They are licking and chewing which a sign that they are happy and relaxed . They have their heads down which means they are relaxed in their environment. My daughter was absolutely happy with her ride on the pony. These ponies are the happiness ponies I have ever seen .

Children need interaction with animals, and not just with dogs and cats. The Pony Rides was not only educational, but hands on experience that will lead children to become animal lovers. Not everyone is rich enough to take equestrian lessons, or even have enough money to go to the zoo. This is a class issue and also racist issue since low income Angelenos are majority Hispanic and Black people. \$5 per child pony rides was DEFINITELY AFFORDABLE, even those who only get government assistance can afford to spend. By not renewing this contract you are actually segregating children from being animal lovers. Many LA residents can't own pets for financial reasons. And once again, Los Angeles with its systematic racism is robbing children of color their future's potential.

We can improve the pony care and still provide this fun adventure for children. Do bBOTH!

Hello - I am a native of Los Angeles and a constituent of council district 13. I am writing in support of the pony rides remaining in Griffith Park . It is an important part of our City's cultural legacy. Generations of Angelenos have been able to have the shared experience of looking back fondly on the memories of this activity with their families. It has been an opportunity for children of all socio economic levels to enjoy time with these beautiful animals and be connected to them and to nature. All the veterinary reports and investigations turned up no abuse. It is clear that this is a purely political decision . My City has caved in to loud pressure from people that do not speak for me - that do not care about or are connected to Los Angeles . The pony ride not only needs to stay , they need to be given all the resources needed to make the animals the happiest ponies anywhere. We do not need bumper cars or educational exhibits - we need the simple pleasures of the joy of a child and a horse in beautiful Griffith Park. I had it, my son had it - everyone should be able to have it.

The pony rides need to be saved. The owners are not cruel, the vets have determined that the ponies are healthy. Please do not give in to knee jerk reactions to an extremist group and look at FACTS before deciding to close down a beloved institution.

I used to take my son to the pony rides in Griffith park when he was younger. It was part of our father son day. After that we would go to the merry go round, train and Observatory.

The pony rides has been a part of LA for 75 years. From what I understand there has been no proof that the pony's have been abused after many inspections. It seems that a few misguided protesters have bullied the owner, parks & recreation into closing the attraction. I believe that there should be more feedback and analysis of this situation to see if the pony rides can be reopened. Also the protester's should be investigated into whether there questionable tactic's were legal.

Would love to see the pony rides come back!! They always seemed very well taken care of and given lots of breaks

Los Angeles Parks & Recreation's purpose is to "provide for the health, inspiration and education of the people of California by helping to preserve the state's extraordinary biological diversity, protect its most valued natural and cultural resources, and create opportunities for high-quality outdoor recreation" ...for ALL citizens and especially the under privileged and lowest of incomes in our Los Angeles community. To inspire children to put down their electronic devices and engage in the outdoors, with their parents, to affordably learn and interact with animals, is a service for the Los Angeles citizens. The Council is taking away a healthy, interactive, outdoor activity, that represents a long standing natural relationship humans and horses have had since the days before the Americas was founded and pioneered. To displace these families of ponies, has created potentially unrepairable emotional stress for them, much like removing a child from their family or siblings and putting them in the foster care system without ANY comfort or information.

Los Angeles citizens' opportunity for high-quality outdoor recreation that help connect children to animals outside of their household, especially if they are economically unable to afford the costs to travel and pay for private interactions and introductions with ponies, horses and other animals, or even to access the referenced miracle sanctuaries from the recent community zoom conversation. Although the suggested "sanctuaries" from the community conversation could be non-profits, they still charge access fees greater than the pony ride tickets cost and are located miles outside of the Los Angeles area.

The counsel's decision is unbalanced and excluded valued equine experts and care givers. It is apparent that the commissioners are cratering or serving their own political agenda's and personal legacy motivations and possibly, undisclosed developer funded influences. This decision does not have the greater number of Los Angeles citizens, families, children and animals in mind and negatively affects more people and animals than the numbers of protestors and uneducated, inexperienced animal rights activists.

Hire a new vendor, if you require a clean start, review and rewrite the contract criteria terms, put a time line around these new terms, add stipulations, timelines and milestones, but do not discontinue the Pony Rides. Innocent, under served and lower income families, who most likely are not aware of the losses being forced upon them, will be the ones who suffer in this decision, along with the ponies.

Bring back the pony rides please

Although transparency is important, LA should have attempted to instill a new manager instead of take away this affordable attraction that connects children with animals. I have been many times with my niece who loves caring for the animals in the petting zoo as well as ride the horses. She knows all of their names and lights up around them. There are so few outdoor activities for kids, especially tangible things and those that involve animals and this is a sad moment for LA. There is no where we know of that offers this at the affordable price this attraction offered.

Comment

This note may be too late as there was very little opportunity for the public to have input regarding the continuation of the Griffith Park Pony Rides contract. As a biologist, animal rescue participant, and equestrian, I support the continuation of the existing contract and allowing the Pony Rides to continue. If the animals are well-cared for, and there are unbiased routine and special inspections, then the animals, children and parents benefit from this unique experience. Horses and ponies are enjoy the company not only of other equines, but also benefit from the interaction with people. These creatures benefit from the exercise and intellectual interaction, and as long as they are on a humane schedule and care, the outcome is positive. Children develop not only physical skills and gain pleasure from the experience, they develop an empathy for animals that is direct and long-lasting.

If this business is halted, then who and where will these ponies be taken care of? Those who claim to be active in support of the welfare of animals do not seem to have a solution to this. These ponies need exercise, feed, veterinary care, and a space to live safely. This is all placed in jeopardy if the pony ride concession contract is not renewed, as the financial resources will not be able to support them.

There have been recent changes in Griffith Park that have had very little, if any, public input. The closure of Griffith Park Rd., is one significant example. There was very little research and study done in that case, and I believe in the case of the pony rides as well. It appears special interests and Ms. Raman's biases are influencing decisions being made in regard to the heritage, usefulness, and accessibility those using Griffith Park. It is very patronizing of those in leadership to determine "what's best" for the public without sufficient input from a broad range of citizens.

The pony rides should be saved. If Steve no longer wants to run it, please let another pony ride operation take its place. These animals are not abused and this is an amazing opportunity for children of all economic and ethnic backgrounds to experience horsemanship. The pony rides and equestrianism are a part of LA history.

It's a shame when a program with a great track record and history in la gets ruined by people that are clueless. Please reconsider bringing back something that has changed and shaped the lives of many angeleños. Make right of your wrong.

Kids need animals especially special needs kids..animals are healers...they also learn compassion and responsibility taking care of them...please don't rob these child of this opportunity..the ponys gave children something to care about and look forward to that the family can afford ..they are possible future horse owners..as i started riding pony 60 years ago and learned that love of horses and have been an owner over 50 years...

The pony rides have helped put my nephew who has autism find a deep love for horses I would take him there every other weekend and he started to talk to the ponys something he didn't do before I think if it wasn't for the ponys he would probably still be non verbal to this day. Please bring them back maybe with new guidelines on how many hours they should "work" but shutting it down completely is a complete monstrosity in the eyes of these children who have grown to love these amazing ponys so much throughout the years.

Why are you giving in to a small group of people. The ride teaches children at a young age Not to be afraid of horses. The ponies are taken care of. Shame on all that voted to close the ride.

Why is Nithya Raman connected to this small extremist group. Why is Jimmy Kim and Bob Blumfield caving to the woman screaming, expletives in front of families with children and should have been arrested. This is who you're listening to over the local equestrian experts who live next door and the vet hired by the city who gave the horses a good report with minor items to fix. We understand that the reason they want to close it was because the horses are not taken care of. If this is it, you are wrong. Or if it's because you want more money, then say that to your citizens. Now your citizens for whom you have been given the job of serving are telling you this is not what they want and they've given you very specific good reasons which include several equine experts and vets. Seems logical that they have proven by majority and proof that it should stay. Do you really think thousands of Angelinos who visit those horses every day would allow them to be mistreated. Tom LaBonge would never have allowed this or have caved to bicyclist who break the law and blow thru every stop sign in our beautiful park because he knew the park he walked in every day and he knew the ponies were well taken care of. He was the best Councilman we ever had and wish he was still here. Look what you have done wrong since he left. Don't send a message to all extremists who don't even live here that if they yell and scream and even be proven wrong, they will get their way. Show them that when the citizens in this town have proof and are proven right is what counts and that is how we run a democracy. Not this sham where Nithya Raman is in cahoots with the big fake boobs woman who is their leader. This is who you caved to??? I was at the pony rides last Sunday with very long lines to ride the ponies. The extremists were there yelling as loud as they could AND THEY WERE PAID \$25 an hour!!! We overheard them say it!!! Does the loudest one win or the ones who have proof of that ponies are well taken care of??? No! Listen to the citizens who have proven this to be the wrong decision and keep the pony rides. Get crazy extremists out of our community. Notice they don't care where these ponies end up-just that they can shut it down. If they're protesting because of the ponies wellbeing, then they would have had a plan for them and they would be concerned where they're going. But it was the owner who worked hard to find them good homes because HE CARES ABOUT THEM. Ever wonder how the 30 year old senior horse got to that age????? If they were not well taken care of, he wouldn't get to that age. If this closes, you will be thought of as the worst board and councilman ever to have the office in 70 years! Don't do the wrong thing by closing them.

Pony rides were a vital part of my childhood and fostering my love of animals. If I were a child now, the closure of GP Pony Rides would have devastated me....and I truly mean DEVASTATED! I can't imagine how many children are going to suffer emotionally from this closure. Pony rides are a stepping stone to riding horses--which I now do weekly & take lessons at my local stable. The ability of introducing city children to becoming equestrians has been lost forever with this closure.

Okay, so what's next? Mark my words...the Los Angeles Equestrian Center will be next. If they are against riding ponies, how do they feel about riding horses? These animal rights activists are extremists. And it's so sad that L.A. Councilwoman Nithya Raman was misled to persuade other council members to close the Pony Rides.

This is all so sick and disgusting, and I'm so sad for the children, and their parents & grandparents who grew up riding the ponies.

One more thing, the activists are making a big deal about four ponies dying this year. Well, how long do you expect a pony to live? Are you going to blame the owner because the pony has reached the end of its life?? They are going to die at some point; people die, everything dies at some point! Ridiculous!!

SAVE THE PONY RIDES!

The pony rides were extremely loved by 99% of people just heartbreaking that just a few people made some thing close down that most people enjoy. this decision was not made by the majority. I don't know how the city let them take the pony rides away when all the animals were taken care of the ones that passed away were retired already, and not being used.

Please keep pony rides. There are children who don't even believe that these animals exist because they have never seen one, as one of daughters classmates voiced this false belief to her.

Why???? I rode there when I was 2 or 3...for years...still have horses....now 75. Cant they leave anything alone that is wholesome and fun ?? Ridiculous. Damn do gooder types ruin everything. If they were unhappy with what they think was going on..why not work with operators to fix it or get new staff on board. Disgusting.

The City of Marina Ca just closed the Equestrian Center there. The only affordable stable in the area...lots of activities.....but some corporation has plans. Shame on them too. Greedy.

Do they both just want families to stay indoors in front of a computer or on their phones ???

No regard for tradition or benefits to the community.

What a sad world we have now.

BRING BACK THE PONY RIDES!!

Please provide an animal free option instead so kids can have a wonderful experience without witnessing the exploitation of animals.

Save the pony rides

Why are you taking away something that had brought joy to children for so many decades? Ruining traditions and family fun because of a few activists even though there was zero evidence of the ponies being harmed. Maybe it can be replaced with a place for people to shoot up, or a new campground for the homeless. Pathetic.....

Please keep the pony rides open, my parents took me to the rides in the early 60s when I was a toddler and I have done the same with my boys. The memories are priceless and would hate to see future generations denied of this amazing experience.

Comment

I ask each and everyone of you to reimagine the long running traditions of our equestrian community. The equestrian community offers an opportunity to a unique experience of interacting with horses and to discover who we are and help us be better people and a more valuable member of society.

I ask cordially to re-consider in keeping Griffith Park pony rides operational indefinitely. We have lost the battle to preserve the Griffith Park Pony Rides and we are losing are our equestrian way of life by a bunch of those damn "animal rights" extremists. They have gotten their way and celebrating our loss of our freedom.

Now those PETA terrorists are now planning on a protest against our equestrian way of life referring to us as "slave owners" and advocating the eventual shutdown of the Los Angeles Equestrian Center.

We equestrians have a responsibility to protect and defend our way of life that is dear to us in our hearts! We must not be intimidated by extremist aggressions! We cannot allow ourselves to be subject to their tyranny and oppression! We equestrians must and we shall stand up and fight for our unique way of life! That way, we shall show the general community that we are the real humans that truly loves animals and nature. Most of all, show the general public the magnificent beauty and connection between horse and human. Therefore we shall live together as one community that respects each other and enjoys the freedom to experience the joy of horseback riding.

Otherwise, Griffith Park will become a symbol of shame and decay. We equestrians must come together to form a fighting force that will protect our way of life! I call upon all of you who cherish our equestrian way of life and horse lovers to voice your concerns to the city of Los Angeles and be not afraid to confront those animal rights extremists!!

I support the well being of ponies and the continuation of the pony rides.

I grew up in Taluca Lake, and Hollywood Hills . The pony rides were a mainstay. People from all walks of life can go there, bring their kids and experience something literally no one else has. I became a successful riding instructor. I owe it to the pony's. They are a tradition. I can't imagine not having the pony rides. We need them.

Please free the ponies

I would like to see the Griffith Park Pony Rides contract renewed to allow pony rides to the public while also looking into possible addition of educational opportunities to be included in the future.

Please save the pony rides at Griffith Park

I am a citizen of the City of Los Angeles, and I attended the protest concerning the closure of the Pony Rides 12-18-22 at Griffith Park. I don't understand why the contract is not being renewed. I implore you to reconsider your position in this matter and reopen the facility for the good of all concerned especially the children of Los Angeles living in an urban environment. These small ventures allow for the first ride on a real pony as I did when I was a child. My first experience was overwhelming wonder for these beautiful animals and led to a lifelong love and respect for them.

I have seen the letter to Matthew Rudnick which finds no wrongs committed by Steve Weeks and with every inspection was found that "the ponies appeared healthy, well-kept and cared for, and appropriately utilized in the riding program; there was no evidence of neglect or abuse". "The Department of Animal Services has found no grounds for a permit revocation or any further action at this time and will continue to evaluate any further complaints." I can't understand what reason can be given for not reissuing the permit. If reasonable additional requirements need to be made, then I'm certain that these can be adhered to.

From the experience on 12-18-22 of (PETA) radical protesters that were screaming falsehoods and misinformation inches from parents, telling them to stop eating meat and become vegetarian, berating them for wanting to have their children ride ponies and using foul language toward supporters and families with children present (and crying from being harassed). In fact-checking, PETA has a kill rate on animals that far exceeds any shelter by a great margin. Their adoption rate according to one source, is less than 1%. They have evolving agendas that include extreme measures about all pet ownership as well. It is unfair to have this harassment happening when parents just want to have a pleasant day with their families.

I would hope that the City of Los Angeles Department of Recreations and Parks would not be swayed by radical groups and would please reconsider the reinstatement of the permit for the pony rides. This could be a threshold to eradicate all horse ownership in Los Angeles. It is my understanding that Griffith Park was given to the city with the understanding that it would be used by and for equestrians:

"Proceedings of the Los Angeles Zoological Society: Volume 1, Issue 1
A PRELIMINARY PLAN FOR THE LOS ANGELES
ZOOLOGICAL PARK AND AQUARIUM
AMUSEMENT, EDUCATION- AND INVESTIGATION
No zoo would be complete without the opportunity given the children to ride upon ponies and donkeys, or even better, to have the thrill of swinging up on the back of a kind old elephant, or go jogging along, clinging to the hump of a camel. There will be a real necessity for saddlehorses and burros to carry adults, as well as children, over the comfortably graded trails from which the various groups of animals may be seen to the best advantage.
Proceedings of the Los Angeles Zoological Society: Volume 1, Issue 1".

While elephants and camels might be impractical, members of the equine family are the perfect choice for children to experience and learn about. Urban areas need to have these facilities available for the children and adults. It gives us the opportunity to relate in a very real way to the natural world, away from the stress of city life. We then live in the moment, relating to this animal here and now as we ride together. Our blood pressure goes down, our muscles relax. Horses, ponies, mules - are our "life" partners. I hope that you can see this or at least try to understand it. Please reinstate the Pony Rides at Griffith Park.

My little granddaughter's first visit to the pony rides was a long-awaited one, since we postponed many things during Covid. The day we finally took her was a very exciting day, and she loved it, but the day was nearly ruined due to the shouting of the animal protesters. They were completely unconcerned about scaring children. They yelled about mistreatment even as we waited in line while the ponies got a 15-minute break with food and water and cooling mist. The ponies seemed very well cared for to me. The protesters went so far as to yell about the parents being Nazis and even called the little children names. I tried going up and speaking peacefully to them, but they refused to interact on a personal level. I did find out that they believe horseback riding should be eliminated entirely, anywhere, which is ridiculous. What is their hope, that all horses should be returned to the wild, where they have no idea how to survive? Crazy. The idea that this type of extremist thinking has won over the city council gives me great concern about the city council. Sadly, my granddaughter only got to ride the ponies that one time. Now, apparently, no more. Shame on the city council. Please reverse this decision.

Bring back the ponies/horses on a more ethical approach. For many City folks this is the only interactions with horses and ponies. Revamp it and bring the herd back.

I hope we can get the pony rides back. They have been there for years and to take them away from the kids for no good reason is wrong please bring them back.

Pony rides. Reinstatement some ponies for kids to get excited about, learn and love.

Comment

If you give your child a pony, they will want to ride. You'll buy them the best pony you can find, followed by a helmet, boots and all the other things pony. You look for a local barn to ride at where you start to socialize with the equestrian community.....And then life as you know it, will end. Before you know it, they want to show so you find a circuitThere will be no more lazy weekends watching tv. You will see more sunrises than you ever thought possible. Every spare minute of your time will be spent hauling campers, horse trailers and horses and enduring a crazy addiction to practice for the next show. Your house may be a mess, and your car will be dirty. All because you gave your child a pony. Your weekends will be spent freezing or burning to death on a fold up chair. And their weekends will be spent gaining confidence and friends, learning new skills and having fun and getting dirty!!!! You will be there the day he or she takes the first few steps of canter, the first taste of a jump, first ribbon, first championship. And they will make you SO proud. Other parents will congratulate you, but you feel weird saying thank you because it's not you on the pony, it's your child. It's everything that they did, they achieved. And right before your eyes, your little boy/girl will be transformed from the baby who bounced around on their rocking horse into an exceptional young horse enthusiast on the hunt for the next pony finals or maybe even the Olympics!

When you give your child a pony, you give them more than just something to ride. You give them a sport, a talent, hope and dreams. Friends, a new family, a place to learn about life, room to grow as a person where they can push their limits, and bravery, and courage, and memories. And they will have ALL of these things, simply because you gave your child a pony.

Because you gave your child a pony, you too will develop new/lifelong friendships, developed solely from the same passion for the sport. You will have a equestrian family because you gave your child a pony.

Then one day, many years from today...they will be in their room and a certain trophy will catch their eye. And they will pick it up and realize instantly that when you gave your child a pony, you also gave them a childhood that they would never forget, at this point, you realize that everything you gave up along the way and sacrificed was totally worth it..... All because you gave your child a pony

I'm very disappointed that there is no more pony ride. This has been something I cherish close to heart. My grandparents used to take me here when I was a kid. I had the best times here. I loved the whole Environment and now it made me feel. Now, I'm able to take my son here and he loves the animals. Seeing his face light up is the best feeling in the world. I was looking forward to taking my daughter here, but unfortunately now this is not possible. I really will miss the pony ride and all it's fun and joy it brought to me and my family. .

The pony rides are the only thing that belong there, screw the activists it is NOT abuse Please consider allowing the Griffith park pony rides to continue. Sharing the privilege of being up close to ponies is not something everyone has access to. And being able to get a chance to experience these animals is very special to children and their parents. The animals are well taken care of and not in danger. Horses ponies dogs can't are all a part of humans lives over hundreds and will continue to be our companions for many more. Please let the rides continue. Sincerely Jeff D

What we need to do is save the pony rides as they are and have been for 70 years! My daughters know these ponies by name and the ponies know these little kids and love what they do. It will be an irreplaceable loss to let this historical part of Los Angeles be ripped away from these children. How dare the council side with these extremists with their false claims and fanatical protesting. These are very happy ponies. I feel sad for our children. I feel sad for Los Angeles. And I feel sad for the ponies. Not to mention the workers out of a job on Christmas.

The pony ride concession was always an abomination, but I don't approve of the zoo either. The old zoo was worse. A zoo should be located somewhere remote in the county if anywhere. Griffith Park has lost sight of its true purpose, to provide natural recreation in concert with education for the people of Los Angeles. Griffith provided funds for the Observatory and the Greek Theater, I believe he would support constructing an education center devoted saving the planet itself, a California "Lighthouse" Conservatory. All this concept needs is leadership.

I'd love to see a low cost, Los Angeles themed miniature golf course. Each hole could feature a different landmark from the city, with a focus on Griffith Park and nearby areas I'm concerned about the way the Griffith park pony rides were shut down. The ponies have been cared for (as third party vet visits have shown). The pony rides provide a critical opportunity for kids to access horses at an affordable price. Protests against the pony rides appear uninformed and based on a lack of comprehension around horsemanship and instead are about a belief that horse ownership is inherently inhumane (false / unsupported). With no public comments the decision to close the pony rides does not take into account community opinion.

As an equestrian, educator and parent living in LA, I support the continuing operation of the pony rides.

Please bring back the Griffith Park pony rides. As an LA native, I remember my sister and I coming here and having a wonderful time. This was 30 years ago. Our parents didn't have much money at the time yet we never felt deprived because we got to experience things like the pony rides. We always had so much fun and loved seeing the ponies. The train rides were great as well. Please bring back the pony rides - the amount of joy that it brings to families of all races, incomes - especially now where it seems it's hard to afford anything in LA anymore - is invaluable. The pony rides were truly a beacon of light for so many families.

I have enjoyed the Griffith Park Pony rides as a child, my kid have, and my grand kids. There are NO substitutes for real animals. There is nothing like the pure joy on a child's face while they are discovering animals, and bouncing on a pony. I am wondering why the City closed the ride down, thus denying this experience. I am also surprised the city allowed customers of the venue to be harassed by these extremist crybabies that were protesting. If the establishment is was out of compliance it was never proved. The goal of the crybabies is to permanently ban the use of live horses. The kids of Los Angeles deserve better than fake mechanical horses and animals. Please email me your response. I emailed the councilwoman for that district and never received a reply.

Thank You, Steven Dennis The Pony rides are a City Historical Landmark and essential to the kids of Los Angeles. How could the city cave in to cancel culture crybabies? They claim the ponies are slaves. Non sense, the owner feeds them, grooms them, provides medical attention when required. Please bring them back for the children of Los Angeles.

~~Steven Dennis~~

Please respond, thank you

For many of us living in a big city, the pony rides are our kid's first and only experience with farm animals. And for kids with sensory problems, this is perhaps one of the few, affordable places where a parent can spend an afternoon. Bring the ponies back!!

I think GP could take some inspiration from The Gathering Place in Tulsa, OK, which has many special, interactive play structures and areas for kids. Beyond that, I think archery or rental bicycles could be a fun idea.

Kids need safer places to bike, this could become a BMX/skate park, and a place for kids to learn how to bike. This would make the park more accessible and inclusive. Don't let extremist shut down pony rides. Exercise is good for animals! These animals will end up on an auction block or in rescue getting no exercise.

I believe that this should still remain open so that lots of other generations can enjoy the ride

Please re-new the lease to keep Griffith Park Ponies open and available for young children. It is a Los Angeles landmark. Children love the ponies.

My children and I have visited and enjoyed seeing and riding the ponies. I came as a child and brought my children after me. I have used this experience to bring awareness to my children about animals and how we use to travel before our new innovations in vehicles and transportation. I feel that if we the public can help in more ways we would gladly do it if given the chance and information. As a minimum wage parent this would be the only opportunity my children would have to touch or even ride these beautiful animals. Many of our children would only have this opportunity due to our current finances or situations. I personally wouldn't be able to afford a horse but allowing my children an experience to ride and touch one is priceless.

Please reinstate the pony rides! It doesn't make any financial sense to close off the ride and lose lease money. The "transparency" is with LA City Rec and parks and NOT the owner of the pony rides. The owner should have been applauded for having a retired pony sanctuary and 4 pony sanctuary deaths were justified. The Equine Advisory Board should have been consulted. Shame on Mr. Jimmy Kim - he should be replaced. Please reinstate our beloved pony rides because there was NEVER any abuse or neglect. Keep out the extremist protesters - have a restraining order against the aggressive protesters making children cry. Please reinstate our treasured historical pony rides ASAP with a RFP IMMEDIATELY!!!

zip line (like riverside park), large fake climbing rocks (like riverside), fake stream, covered bridge (see kidspace)

Comment

Please keep the pony rides! They nurtured my love of horses 60 years ago, and these days its even more important for children to be exposed to animals theyotherwise might never see!

Dear Department of Recreation and Parks,

I am writing in regards to the Griffith Park pony rides.

As an equine veterinary technician and an equestrian of over 30 years, I can assure you that Steve and his staff take very good care of the ponies. In fact, they are very well taken care of. These ponies are well feed, rotated so they can rest, and handled with care.

I've ridden there as a child, and I am a responsible equestrian and have owned horses, and a veterinarian technician professional who can honestly tell you that these ponies ARE NOT abused.

The protesters have no knowledge of horses or ponies. They are neither veterinarians nor veterinary technicians. They only see what they want to see. The pony rides are no different than someone owning a horse and riding it. The pony rides are in important establishment to the Griffith Park community, as well as the equestrian community. The Griffith Park Pony Rides brings incredible amounts of joy to kids, and give them an opportunity that they would otherwise never have. Please do not take this away, because of a few people who scream and yell, and have no validity to their argument.

Thank you for your time and reading this.

Sincerely,

Griffith

Please keep the pony rides in Burbank. These pony rides are a wonderful way for children to experience the horse culture, when they would otherwise not have a chance to do so. This is the essence of BURBANK!

The pony rides are a historic landmark and a rare opportunity for inner children to be able to interact and ride. Please return the pony rides!

They pony rides can't close because of a few activists. I am a vegan and animal rights supporter, but I also understand horses and they are animals that have been domesticated for many years. Some even get sick when they aren't ridden.

Please open back this family friendly tradition in Griffith park.

Comment

To whom it may concern,

I saw Zora screaming at the birthday parties one day so I stopped and I told her she was scaring the children a few were crying.

This was after the vet check passed so I didn't understand why she was still out there screaming her lies.

The vet check debunked her false animal abuse accusations yet she continues to smear his name.
And Then somehow she won?

She screamed at me that I was an animal abuser and owning horses was slavery. She said I was a slave owner.

I tried to explain to her that she should be down at the auction where they sell the overpopulated horses to kill factories.

I asked her if she knew about the mustangs problem?

I asked her where will the horses go?

Sanctuary's s? I asked her if she knew how much it cost to keep a horse... who's going to pay...

A person on a horses back a kid on a pony's back is like a person carrying a backpack.

They think when a pony's head is down it's sad but that's how they relax or rest...or look for food

A simple Google search can tell you this.

Quote. A dropped head is a sign your horse is relaxed and feeling good. If he's standing in his stall or pasture with a lowered head, he's probably either resting, relaxing or asleep.

They have no knowledge.

They have no facts.

They have no solutions.

Griffith Park Pony Rides have been there for 73 years. Packed every weekend with happy little kids.

I've met two and three generations there. Family traditions.

When the ponies retire they get to stay with their herd and receive love and care until they pass.

They have rehomed numerous ponies into our community and I'm sure have been used by the studios over the years.

Her complaints had been addressed and resolved.

A vet came out and inspected and if passed. So what changed?

What facts have been presented?

What were the new legitimate complaints?

I think we deserve to know.

I haven't heard a valid reason yet so my suspicion is they were sick of her coming to their offices screaming so they caved to an obnoxious extremist activist who is uninformed and has zero evidence of anything that supports this action.

Who is fighting for the Equestrian community because I keep reaching out to my local representatives and get crickets and we're losing ground every day.

Activists don't understand and obviously the politicians don't understand that many horses/ponies without jobs or a purpose are often sold for meat or glue or euthanized.

I would like an answer on how this happened. This was wrong.

~~Shirley Harts~~

Please do something with horses or nature in this place that honours the history. No bumper cars or carnival or mini golf. The equestrian nature of Griffith Park is very quickly disappearing. Also why haven't you taken over running the carousel?

<https://www.hmdb.org/m.asp?m=212780>

Do not shut down. This allows for our children to learn and respect animals through interaction.

As a long time resident of LosFeliz I was shocked about the sudden unexplained disappearance of the Griffith Park ponies. When my kids were small we spent many enjoyable hours riding the ponies and trains in Griffith Park.

Replace the pony rides with a non-animal model, like an awesome playground

Could you please build a non-animal venue in the place of the pony ride? Something a family can enjoy like a miniature golf course or a fun zone.

Please provide non-animal alternatives for Griffith Park like FUNBOX, GoCarts etc

I am so very grateful you shut down that horrible pony ride in your beautiful park! My hope is you will replace it with non-live animal activities. Maybe an interactive Interpretive Center honoring P22 and educating about the benefits of mountain lions and other predators like coyotes to the landscape in a way that fosters respect vs fear. Of course, you might want to do something more fun for kids like inflatable obstacle courses etc. Whatever you decide to do, I hope it will be entertaining and informative. Thank you!

Please replace the pony rides with go-karts, or a carousel, or obstacle course. Something that is fun and doesn't require animals. Thank you

Non animal please. No animal use.

Thank you so much for NOT renewing the Pony Rides contract!! PLEASE decide on a fun, affordable attraction for kids & families that does NOT INVOLVE LIVE ANIMALS! No matter who or what, the animals will suffer; they will be confined, depressed, often suffering in pain and basically slaves. Please this is not fair to any animal and not right to teach kids that it's ok to chain and confine them in any way like that. Thank you for your consideration.

Please replace Griffith Park Pony Rides with a non-animal model. There are so many options that do not involve animal exploitation which is not something we should be promoting and teaching children in this day and age

Please choose a non live animal model ! Thank you very much.

It is important to replace the ponyrides with something for kids that does not include live animals, because animals suffer for human enjoyment. As horse and buggies are now going EV, Griffith park could include something fun and electric like bumper cars.

It is absolutely essential that a non-animal model replace the Griffith Park Pony Rides! We are trying to teach future generations that animals are not objects. Go carts, miniature golf, bumper, cars, science museum for kids, nature center, the possibilities are endless!

Comment

I would love to see something that does not involve live animal like a splash pad, putt putt, or go karts.

Please provide a non-animal alternative. Go carts, etc.....

Please do not bring any more cruel animal exploitation back to Griffith Park. Let's normalize and encourage compassion and kindness towards animals and provide non-animal recreation to the park: go-carts, fun equipment to play on/exercise on, horseshoes, go-carts, a big slide, self-pumping merry-go-round, etc.

Thank you.

I want a non-animal model such as FUNBOX. No animals should be used for amusement, it is cruel, High maintenance, should use this opening to implement things that are educational, sustainable, compassionate and fun. I have been to many parks with state of art fun games and interactive activities, swings, turn tables, climbing walls that everyone loves and Never include live animals. Thank you

Thank you for removing that archaic model for entertainment and your willingness to create something special and new. Something as simple How do you do and exciting as A modern looking hi tech jungle gym with cargo nets and suspended obstacles would be fantastic. Interactive themed large art installations would be incredible as well. There have been a tremendous amount of installations from artists that have come out of the burning man festival who have placed their work all over the country with great reception. Thank you for your willingness to do something valuable and humane.

Please use a more compassionate, non-animal model. Animals are sentient beings who cannot consent to their use. They're not here for our entertainment. Please add something fun like go karts!

Please replace the pony rides with a non-animal attraction, such as go karts, mini golf, or an obstacle course.

Strongly advocating for a non-animal option, go-karts or something equivalent, in place of Griffith Park and Pony Rides and Petting Zoo. Animal abuse is not ideal.

Please have a non-animal entertainment such as electric carts, a merry-go around, go-karts, or other fun activities, having animals is sad they are always sad and hurt and they smell, it's very expensive to keep them healthy, please let kids enjoy without seeing sad animals, replace the Griffith Park and Pony Rides and Petting Zoo.

Can we PLEASE STOP USING ANIMALS FOR PROFIT? Why can't they use that space to create a kid friendly go kart facility so the kids can enjoy something related to the existing Merry-go-round? It was be amazing to also EDUCATE the future generations reminding them why we should exploit innocent animals. I used to ride those ponies when I was a kid but I don't think kids these days want to see animals who are not cared for and overworked. Los Angeles banned circuses with animals so why is this pony ride any different?! The space can be leased to evolved people with visions that will not only keep animals out of the equation but also provide something new and improved for the children. Thank you.

Please change the pony ride area into some thing, sustainable and not cruel. We need a non-animal model, and some thing that is environmentally suitable. Electric trains, electric, go carts, something of that nature would be fantastic. Do not bring any animals back as they are not ours to abuse and deserve freedom and compassion, Not being used for profit. Thanks.

Please replace the former Griffith Park Pony Rides with an enjoyable non animal family oriented model, perhaps such things as electric go karts or a roller skating rink for families to participate in activities together.

Please have a non-animal model such as a putt putt course or amusement rides or go carts, replacing Griffith Park and Pony Rides and Petting Zoo. Please do not use animals for any type of entertainment. Thank you.

Please provide non-animal entertainment like go karts or other similar kids rides.

I definitely 1000% percent support a non animal model of engaging fun activities!

Go-Karts, an updated better or futuristic and larger carousel with cooler fictional animals like a Pegasus or unicorns maybe!

Maybe a next level playground with more fun interaction in it like spaceships and big pirate boats they can bounce around in or use their imagination in portraying with cool devices that look real but teach them math and science in how they use the devices on the "spaceship"!

That sounds ten times better than some sad dull looks on a live horse that is depressed and malnourished and obviously not happy.

I remember getting on those ponies as a kid and it wasn't even fun and I thought I might get ticks or fleas because of how dirty they kept the horses...and many people reluctantly go because we all think that's the thing to do and it's passing time and we think it's fun, but let's be honest...it's not a lively good family bonding time with those horses. I bet alot of parents want to give their kids a bath after getting on those horses and don't remember the experience for more than a week.

Even if they did love it, there's better places they could get a ride and lesson from with well treated horses from orgs that don't treat the horses in an entitled way, but an indigenous and respectful way and aren't beaten into submission either like many of the 500,000 animals across the world used for tourism and entertainment.

Thanks for your time and energy in updating our humanity to match up to our society.

Peace~

Thank you for not renewing the contract for the Piny Ride Concession. Thank you for showing compassion for animals. It is 2023 and people are aware that animals are sentient beings who deserve to be treated with respect. They are not in this earth to be used as 'entertainment' for human beings. Please, replace the Pony Ride Concession with a Non Animal Model. Go carts are great and children love them. Obstacle courses, trampolines ,zip lines, bouncy castles, ... there are many fun activities for children. Teaching them to respect animals and care for them is one of the most important lessons we can teach our children. Please, replace the ponies with a Non Animal Model Concession. Thank you so much.

Thank you with all my heart for closing the pony rides and ending their misery! Thank you, thank you, thank you! It's the best news I've heard in a long time. I am incredibly grateful that the suffering of the ponies has finally come to an end. Please replace the cruel rides with non animal concessions that will delight and entertain children without harming animals.

Please replace the Griffith Park Pony Rides and Petting Zoo with a NON-ANIMAL model. It makes absolutely no sense whatsoever to make the decision to stop abusing those poor ponies, only to turn around and put in place some other alternative that forces animals into a similar kind of slavery. This is an opportunity for Los Angeles to demonstrate that it is a city of compassion. There are so many non-animal alternatives like go-karts, inflatable obstacle courses, etc. Please don't cave in to pressure from those people who stand to profit from offering "entertainment" by forcing animals to do the same thing over and over again endlessly, day-in, day-out. There is a better way.

I believe that this area should be used to bring families together and to provide education as well without the use of any animals. Things like a Fun pack bounce area for kids and a bounce (obstacle course) for families and adults. Since P22 just passed, this can also be an area to create awareness about the wildlife in and around Griffith Park.

Please consider bringing a non-animal exhibit or recreation opportunity to this space. As Travel Town has demonstrated, visitors and children are equally engaged and delighted by such areas. Anything from go-kart rides, to an outdoor exhibit that expands on the Autry museum, would be much appreciated!

Please have an attraction that does not have animals and offers kids the chance to get exercise and have unstructured play.

Please whatever you decide to do with the old Pony Rides concession - replace it with a non animal model. Maybe a kids fun zone - something the whole family can enjoy. Thank you. Thank you for bringing that hideous spectacle of animal abuse to an end and once again setting the example for a more compassionate world.

Please replace Griffith Park Pony Rides and Petting Zoo with a non-animal model such as go-karts, sustainable gardening, or an inflatable or corn maze.

Comment

Thank you again for closing down the pony rides & petting zoo. It was the right thing to do. It's sad to see that the horse community cannot accept your decision. I think it's very disrespectful. While I am not surprised that the LA Equine Advisory Board supports the pony rides because they would never object to any kind of riding. But their support of horse racing where 60 horses in California were killed last season as well as rodeos where horses are killed often, only proves that they do not have the equines' best interests at heart. It is obvious that they support any use of them, even if that also entails abuse.

Please make sure that you replace the pony rides with a non-animal model. There are many other kinder activities to offer families. In Woodland Hills, there has the largest bounce park that appeals to the whole family & the many different aged children and doesn't entail animal suffering. It also gets kids to exercise which many do not get enough of these days. It's called FUNBOX.COM. The 9000 foot maze has obstacle courses, dodgeball, a Ninja wall, slides and much more.

I urge you to look into this possibility & others. Thank you again for retiring these poor ponies and farmed animals.

A wonderful use of this space is to offer Go-carts rides for the kids around a track. This will be more popular as children LOVE go-carts. It's been done over decades at many theme parks and would be a welcome edition to the park.

We don't want you to use animals anymore. Find a cruelty free alternative

Please replace the pony rides and petting zoo with non animal entertainment. Thank you.

The future goes beyond using animals for our entertainment, let Los Angeles lead by example. The future is now.

Please do not offer anything that involves live animals. As we have seen from the pony rides, the potential for abuse is possible. I would like to see educational options involving the arts or music or perhaps a playground.

Hello, it is my understanding that the pony rides at Griffith Park were shut down because the ponies were suffering. I applaud this compassionate decision. That said, it does not make sense that the pony rides would be replaced by pony rides. Please replace the pony rides with a non-animal attraction or leave the area as a natural space for the citizens of Los Angeles and wildlife to enjoy. Thank you!

Please do not replace the ponies with more animals. They are subjected to extreme weather, no matter the good intentions, outdoor weather cannot be controlled. We must send a message to our children that animals are to be respected, and should not be used for entertainment.

Please have a non-animal attraction such as mini golfing, replacing Griffith Park and Pony Rides and Petting Zoo. Thank you.

A carousel and picnic tables/area would be a beautiful idea.

Please consider a non-animal attraction to replace the pony rides and petting zoo. Possibly a bounce house playground and/or go-carts and kiddie rides.

Thank you for not extending the contract for the pony rides. Those poor ponies having to do circles for hours. Kids love those inflatable obstacle courses or bounce houses. I know my kids go crazy for them. I think in this day and age something like that would be a huge hit. It gets kids to be physically active and having fun doing it.

I love Griffith Park, but seeing animals exploited honestly ruined it for me. I have 3 kids and I would love to bring them to Griffith Park. Maybe a wall climbing gym. Maybe miniature golf. Maybe a zen garden. It is such a beautiful space for connecting with nature. Don't ruin it by animal exploitation.

Please replace with non-animal attraction such as go karts or expanding train ride.

NO ANIMAL should ever be exploited for human profit greed and or human entertainment. Be the change Please show kindness and compassion towards these Beautiful souls All Animals deserve dignity freedom and life. There's so many other options to build something educational and wonderful for the children like a science center even a water park with slides. They don't need to be a part of Animals suffering due to the ignorance of humans.

This area will be better off without animals being used for entertainment. A recreation area with go-karts and other fixed play areas will serve the community better and provide jobs with no animal abuse in the mix. Thank you!

Please replace the animals with non animal rides .

Please provide non animal activities. The pony rides are cruel! Go karts are much more fun for children

I would like to see go karts instead of the pony rides which I found cruel. or water slides. so many fun things can be set up without using non human animals. I know I would bring the kids and grandkids if fun things are there to do other than what will be stopped

Please no live animals at Griffith Park! There are many alternatives to interesting fun activities that can be provided there without including the exploitation of animals! Thank you

We would like to see non-animal entertainment at the park such as go-karts.

Please provide non animal activities at Griffith Park such as climbing walls, arts and craft booths, inflatable slides, ethnic food booths, go-cart track, walking paths, gift store, merry-go-round with cars (not horses),

electric carts to drive around a track, laser tag, zip lines, panning for 'gold', and expand the train track ride already in place.

Thank you!

Please replace the pony rides with a non-animal model attraction such as go-kart. Other forms of entertainment that exploits animals should not be considered

Please adopt animal-free entertainment models instead of age-old animal enslaving activities. Educational interactive displays such as those kept in children's museums would intrigue younger audience. Riding a mechanical pony would still be more humane than enslaving and forcing actual animals to bear our weights.

Please consider replacing the old pony rides exhibit with a NON-Animal model. I worry people will continue to abuse animals and still not understand that they should not be exploited. Go karts or even a maze would be fun. Extend the train ride to include a longer ride. Even a water / plant exhibit would be exciting to teach children about plant life. Thank you so much and I hope you will never allow animals to be exploited here again!

Please use non animal activities like go karts etc

Please make the change to a kind model for all. Animals for entertainment is a very outdated approach. There are so many options for entertainment which do not include the solicitation of animals. Introducing oppression over animals at a young age leads to less empathy and more violence in our children's' futures.

The ponies do not deserve to live a life of slavery. To have children climbing on their backs all day long kicking their naked bodies for many hours of the day.

Non-human animals are not entertainment.

They have feelings, feel pain, and do not want to be exposed to abuse, just the way we humans would not.

Just leave them alone already, they have suffered enough. Let them have a life of peace. Please be kind to all kinds.

Please reconsider any use of live animals for the purpose of entertainment when determining what to do with the pony ride area at Griffith Park. As a society we have learned from the mistakes of circuses and moved past the idea of using live animals for entertainment. I am confident that several non-animal solutions are available. Thank you for your time and consideration

Please look into a non-animal replacement for the pony rides. We have been conditioned in our society to exploit animals for entertainment. Often, they are mistreated. There are many other options that will not harm living beings and will be more fun for the children. Thank you for your consideration.

Please make Griffith Park a non-animal model. There are countless ways to entertain children that don't have to include animal exploitation. There can be go karts, obstacle courses, tree top adventures, or a carousel.

Please do not allow pony rides or any other animal encounters as entertainment at Griffith Park. Offer cruelty free attractions. Thank you!

Comment

Dear Commissioners and Representatives: As a long time resident of West Los Angeles, I am stunned and concerned about the unfortunate image given this vibrant and progressive city created by the Griffith Park Pony Rides. Surely an activity operating for 75 years is not the means to provide our kids with inventive activities to help secure their future growth. It has been well documented that the Pony Rides were catastrophic to the elderly ponies and to children participating in this archaic, concession. Some ideas about how to change this decades old practice into a modern-day attraction might include: programs focusing on space along with telescopes, fun activities like go-karting, as well as educational and cultural programs for kids to learn and explore.

Thank you for considering other businesses and activities so that Griffith Park is viewed to be a leader for others to follow!

Please do not reopen Griffith Park with pony rides. Please use a non animal model such as go carts.

Nithya Raman I voted for you, but you need to stop cutting back activities at Griffith park and use that energy to address the humanitarian crisis of homelessness here in California, which is what you ran on and promised you would do. So far I have seen nothing! There are still tents pitched up and down along my neighborhood. There's garbage everywhere, needles on the sidewalk, people defecating out in public and dying everyday on the streets.

Your heart beats so sensitively for matters, such as ponies dying well there are human beings dying due to homelessness everyday why don't you do something about that, instead of taking away activities from children at Griffith Park?

It's bad enough you've cut off access to Wilson golf course which has created a traffic jam everyday between the hours of 4:30 to 6:30 PM on Zoo Dr. I'm getting tired of these pony self interest groups that pass themselves off as these bleeding heart activists who in fact really don't care about anything but their own self interests. I can't believe that because one cyclist got hit by an idiotic drunk driver on Crystal Springs Dr, a completely unrelated St. you shut down an entire section of the park off to thousands if not millions of innocent law abiding citizens, who have been using and enjoying this road for decades. People coming from Toluca Lake/Burbank now have to wait in long traffic jams to access Autry Museum, LA Zoo, and Wilson Harding golf course. I have had a long tradition of going playing golf at Wilson Harding golf course after work. Now due to the closure of Griffith Park Dr. I've stopped going. It takes an hour to get there during rush hour, not to mention the ugly traffic jam it has caused through the park every afternoon. What's next? Shut down Travel Town because a kid slips and falls while playing on the trains? That seems to be your logic.

This pony ride has brought joy, happiness and has been a positive experience for the ponies and the families since 1943. An opportunity for kids and animals to come together and share love and appreciation for each other in an urban area. The report came out and said no ponies were being abused so why are you doing this ?

This pony ride at Griffith Park must and better get opened up again or I will personally volunteer and dedicate my time and powers to make sure you will not be reelected!

Commenting

Please do not allow another business that uses animals to open. There were nothing but complaints and law violations with the ponies and this is just another opportunity for history to repeat itself. Please encourage businesses to open using non-animal entertainment practices.

Instead of pony abuse, we would like our children and families to use the area as a mini-golf course. We could always use it as a healthy restaurant, carnival rides and cotton candy, nature walk area, coffee house, mini observatory for kids, rock climbing, or a mini science center.

Pony rides should NOT continue. These poor animals don't need to be used for this purpose. There are many other things that can be done. Let the ponies run free in a sanctuary. PLEASE!

Please support a non-animal event like go-karts in place of the horse rides that were treated inhumanely. Thank you very much!

Commenting

Please have a non-animal attraction to replace Griffith Park pony rides and petting zoo..... Perhaps go carts or an inflatable track/obstacle course.. Thank you..

Please replace the horrendous live animal model with a non animal model. Children love carousels, and living being wants to walk in circles, or work all day without pay.

Hello Please replace real ponies & real horses with a non-animal model such as go-karts, inflatable obstacle courses, etc. Thank you

Please have a non-animal model such as go-karts replacing Griffith Park Pony Rides and Petting Zoo.

There are so many fun and interesting ways to reimagine the pony ride space, but whatever you decide, PLEASE do not use live animals.

A few cool ideas for the space:

<http://ruralstudio.org/project/lions-park-playscape/>

<https://www.onlyinyourstate.com/colorado/denver/peter-pan-park-denver/>

<https://worldlandscapearchitect.com/woodland-discovery-playground-shelby-farms-park-field-operations/>

Try to use sustainable materials. Ask kids what they want.

Please use non-animal forms of entertainment. Animals suffer needlessly when exploited by humans.

Please use non animals models such as go carts.

Please have a non-animal model, like go-karts, a botanical garden, an area for picnics, a putting green, an outdoor workout area with pull-up bars and such, or a chill place to hang out with hammocks.

please have a non-animal model such as go-karts, replacing Griffith Park and Pony Rides and Petting Zoo."

Please do the right thing and chose a NON-ANIMAL form of entertainment at the Griffin Park Pony Ride and zoo. It is disgraceful that it is taking so long for LA to rid of this dated, dangerous and inhumane zoo/pony ride. Thank you.

Please do not bring pony rides back. They are cruel and outdated. Please respect all beings.

Donkeys and mules are intelligent animals that need to be treated with respect and not considered an object! Thank you very much.

Please don't use animals for entertainment! It would be way better to do something else like a beautiful carousel (like the iconic Carrusel de San Sebastián), or go-karts, or trampoline bungee jumping!!! So many wonderful cruelty-free options that don't involve exploiting animals. We need to leave animals alone!!!

Please replace the pony rides with non animal fun instead better for the animals and better for the kids.

Please don't bring back the pony rides, or anything else that involves animals. It's 2023 and we don't need to exploit and abuse animals for entertainment!

There are many other ways to use the space for families to enjoy, such as playground equipment, splash pad/wading pool, or go karts. Thanks for your consideration on behalf of the animals who cannot speak for themselves.

Thank you so much for this platform! Animals were not put on this planet for entertainment!! There lives mean as much to them as ours does to us! Please adopt others forms of entertainment without animals! Compassionately, Joey and animal family

No animals should be used to give kids rides!! Get a carousel, just use a non animal model, please!!

Why not try using go carts or bicycles with carts on the back that people could ride on?

No More Pony Rides. It is Abusive!!

Please replace the horse rides with a non-animal ride! Thank you for your consideration

Please have a non-animal model like go-karts or bumper cars to replace the pony rides & petting zoo

It should be using no animals any more and I prefer something athletic so it will be much nicer for both animals and children.

Abolish pony rides and petting zoo at Griffith Park !

Comment

Having walked past the pony rides many times since I moved to LA in 2007, I was always saddened to see the equine body language and working conditions. Raised in Iowa, equines were a central force in the first 22 years of my life, I have a passion for them, and always enjoy introducing people to horses and helping beginning riders. As I spent so many years around horses, the pony rides were depressing and even at times infuriating. I am quite joyful that animals will no longer be subjected to such terrible conditions in Griffith Park! Thank you so very much for getting rid of the pony rides and please never bring them back!

Anything other than animal abuse. No animals need to be here

Don't renew the contract

Please replace the Griffith Park pony rides with a non-animal alternative. There are so many other choices that could be implemented such as go-carts or climbing wall to name just a couple.

Please replace the pony rides with a non-animal model. These rides are cruel and abusive to the horses who only want their freedom!

Stop!

A Community garden would be a good option

Something like go karts would be cool!

Trampoline park

Do NOT allow any animals to be used at Griffith Park. Children shouldn't be exposed to using animals for profit. It always ends up harming the animals and teaching children to be immune to suffering.

Pony rides subject these horses to heat and being pulled going around in a circle all day with hardly any water or rest.

Please ... leave animal exploitation out of Griffith Park.

I hope you'll consider instead, having a non-animal model such as go-karts, a merry go round, or inflatable obstacle courses... Anything that bring children joy without exploiting and using animals.

Please replace the pony rides in Griffith Park with a non-animal activity or entertainment. Animals are not ours to exploit for profit. Thank you

Thank you for considering my feedback. I'd really love to see a business that does not use animals. It's very hard to regulate to make sure they are treated properly (as you've seen already with the pony rides), animals offer easier exposure to diseases, and they are much more expensive to manage. And much MUCH more expensive to put the animal's welfare first. I want a safe and positive space to share with my family and that means providing activities that don't include animals. I have faith in the committees to be creative and find a great alternative!

I think yall should re-imagine the area into something for children, maybe educational, maybe entertainment, like mini golf, a garden, go karts, a pool, laser tag anything that does not exploit animals so that our beautiful city can progress and we do not have to relive the hostility with concerned citizens and the exploitation of animals. Thank y'all.

Please replace the pony rides with something that does not have animals in it so there is no possibility of animal suffering. Anything like go-karts would be great. The kids and families can still have fun and animals will not suffer.

Thank you so much for closing the pony rides concession, that place was so sad. Please open something without animals, which will always be subject to abuse and neglect. Some thing with sensory engagement would be great—maybe large installations of gears, pipes, etc. Things where you can crank a handle and watch something turn, big pipe sections to crawl through, maybe a water area where kids can put there hands in a water table. All of these things would require minimal maintenance and would be low liability if planned well. Cheers on making the right choice, and best wishes on the design process!

Orta

Please do not do pony rides. Let's have entertainment without animals involved by having go karts or an arcade.

Please establish an animal free venue at GP. Some ideas include go carts, rock climbing gym, art venue/studio, farmers market, mini golf course.

Please stop the abusive mistreatment of these beautiful creatures. This is a profit driven entity that cares nothing for these animals. This is animal cruelty pure and simple - we are better than this. Please be an example for the rest of the country and stop this now.

Stop supporting Animal entertainment

Please don't bring these events back. Pony's don't deserve this and would hate to see it back. Pony's deserve to be respected

Cruelty should never return

The pony rides were cruel and of the past. Stop exploiting animals. Get a carousel if kids want a ride.

Thank you for closing down the Pony Rides and Petting Zoo at Griffith Park. I have been a resident of Los Angeles for over 25 years and I am happy to see the city is moving away from using animals as entertainment. There are so many better ways for children to engage with animals with compassion such as at animal sanctuaries. I kindly ask that you replace the space with a venue that does not involve animals.

I appreciate your consideration.

A non-animal model would be great such as go carts or inflatable obstacle courses or arts and crafts such as drawing/painting/pottery/ or maybe a zip line.

Animals aren't ours to use for entertainment. Please replace the Griffith Park pony rides with a non-animal model.

I think it's highly commendable that this cruelty has been stopped. A permanent ethical and non-animal alternative appropriate in the 21st century

Please find alternate forms of play for children that don't exploit animals.

Please replace pony rides with a non animal model.

We are unfortunately live in 21st century, not Wild West anymore. Let's live in our time and stop continuing Wild West's outdated habits. Lets bring none-animal model fun programs for our new generations and teach them respect humans and animals instead of using and abusing animals and each other.

Hi- Please end the use of animals in city parks. The use of animals causes an increase of air pollution and toxins that pollute the ground and water, as well as fly infestation. The smell from Griffith Park Pony rides was overwhelmingly foul. This triggers asthma. The use of animals as any kind of transportation is unacceptable as there is no "humane" way to force animals to submit and carry humans on their backs. The Griffith Park pony rides regularly committed animal abuse offenses such as denying ponies adequate rest, water, and escape from heat. There was a weight limit of riders which was also ignored on a routine basis. I respectfully suggest bike rentals, electric carriage rides, or recreational sport offerings such as mini gold or lawn bowling to add interest and participation in our city parks and recreation areas. Thank you.

Please don't use animals for entertainment

NO PONY RIDES PLEASE! A rock wall or go-karts or inflatable obstacle course would be way more thrilling without exploiting animals.

Is it unreasonable to not exploit and abuse animals?

Please create a non animal model for Griffith Park.

This will be cost effective and not cruel.

Thank you

Please do not replace Griffith Park pony rides with another animal entertainment venue. This will only result in more animal exploitation and suffering. Please seriously consider non animal forms of entertainment such as a ropes course, go karts, or obstacle course; anything that will provide fun exercise and skill development while causing no harm to animals.

Thank you.

Please provide a non-animal form of entertainment to replace the pony rides in Griffith Park. There are several types of educational and entertaining models to provide activities for children that do not include animals. This is the 21st century and we have discovered that using animals for human entertainment turns out to an exploitative disaster. This would only cause more suffering and more controversy in our community as more people wake up to the reality that animals are not here for us to use and abuse.

Exploiting animals for entertainment is grooming kids to be callous and not nurture empathy towards animals. Growing up lacking empathy is the cause of human demise, conflict and fights. Pleaser don't open another animal exploitive business at Griffith Park. There are so many other fun and attractive operations that teach kids to be well adjusted children and adults. Potato sack racing, arts and crafts center, playground, fun exercise course are all useful and good for kids.

Comment

Hello , I would like to please consider have no animals at your park , it will send a sting message to the public that animals shouldn't be exploited. It would also be more costly and require someone with real knowledge for their care .

The time is now to have non animal events such as a bounce house , go carts , a maze ect around the country many states have banned the use of animals for rides . Please be a leader , it would also show the public that you take their concerns seriously after the bad press the park has received. Thank you . Sincerely Kathy marhefka

Please replace the current model of pony rides at Griffith Park with a non-animal model. They are available now, are far more financially responsible, and the biggest reason..... they're better for animal welfare and the environment.

Please stop forcing animals to provide services for human profit. It's outdated, cruel and unnecessary. These horses are used and worked until they cannot work anymore and then shipped to slaughter in Mexico or Canada. We don't need these practices anymore. Stop petting zoos.

Please have a non animal model such as go kart or inflatable obstacle instead of pony rides or petting zoo.

Please stop pony rides

Please replace these outdated and cruel pony rides with a non animal entertainment option.

Please replace pony rides with a non-animal model. The ponies suffer immensely from being ridden. It is completely unnatural for them to have anyone on their back. It causes them to sustain injuries. Why not have some mechanical rides, or games, or something just as entertaining without hurting another being. Let's bring this attraction into modern times and leave riding ponies in the past. Thank you for your time and consideration.

Publicly abusing animals is bad enough, but to 'teach' children that it is acceptable, is just wrong and evil! Give children THINGS to love, and play with, NOT captive abused living animals.

I think any thing with live animals wouldn't be necessary or useful. Installing some sort of educational center would be amazing. Perhaps a sort of learning annex that would deal with learning about California native plants, rocks or animals. Perhaps a history of what Griffith park was, is and will be. Growing up in the Antelope valley we had something like this for Devil's Punch Bowl and it was very exciting to attend as children.

More pony rides

Please replace the pony rides and petting zoo with non-animal activities such as go-karts

Please replace ponies with non-animal rides such as a natural learning center, amusement park rides, go karts, activities like dance lessons, theater, creative activities. Teaching crafts. End animal cruelty.

I do not want pony rides to be back! Maybe go carts would be a good replacement option!

Take good care of the ponies, keep them safe and happy

Let's stop animal abuse!

Thank you for making this decision. It's what's best for the horses. The pony rides were an outdated form of entertainment. It would be great to replace them with something that doesn't involve animals, like a playground or something!

We don't need Pony rides. Clear violations of animal welfare have been violated in the past over and over. Our community does not want animal acts! Give kids go-carts and fun activities. Fun without cruelty.

Set a good example for our kids please!

Stop all kinds of animal abuse and cruelty.

A skate/bike park and recreation center with info, outdoor gear and bike rentals, guided hikes/rides, and cafe

Please provide non animal options. A park with swings and equipment would be great. Or exercise bars is also great. Even a carousel would be nice. But NO LIVESTOCK!! Its cruel.

Please replace the pony rides and petting zoos at the park with a non animal models. There is no reason in this day and age to abuse animals via pony rides and petting zoo attractions. A better alternative would be go karts, obstacle courses, planting/edible gardens, water play area, etc. Let's do better. We can be leaders here, and show everyone there is a more compassionate way forward that does not rely on the exploitation of animals. Thank you.

I support a non-animal restructure where no one suffers. Or families can congregate and enjoy a day of Coke carts obstacle courses enjoy being outdoors in a beautiful park area.

There are many things that can be done instead of making innocent creatures suffer.

There hundreds of amazing and engaging ways to use this space that do not use animals. The city is ethically obligated to chose one of them. Mini golf, disc golf, interactive playgrounds, and so much more.

Please replace the cruel, unethical, and unnecessary pony roses with another form of entertainment, such as miniature golf, or perhaps some types of art classes.

As sad as I am to see the ponies go, I think it would be a wonderful location for a more public amusement. Maybe a public pool, a skatepark, a bicycle pump track, or a horse stables themed kids playground!

Please have a non-animal attraction, something like go-karts. Thank you General Manager Jimmy Kim for not renewing the Griffith Park Pony Ride contract.

Bike rental, nature center, little amphitheater

Please replace the pony rides at Griffith park with something that doesn't involve animals. I think a little train would be perfect. Thank you for your consideration!

Please do not resume this awful cruelty! There are so many better alternatives and ways to entertain kids and adults like go-karts, inflatable obstacle courses, etc.

Please this cruelty must end!

Please replace the pony rides with a non-animal experience. We need to stop teaching our kids that exploiting animals is acceptable.

I think a community garden with gardening classes for kids would be wonderful. Kids could learn to respect the earth, learn how plants grow, and get to try fresh fruits and vegetables.

It is cheaper to maintain a fake horse than a real horse.

We live in the 21st century and have a responsibility to create a better world for our children. Please have a serious discussion about recreation without exploitation of animals. For example, instead of pony rides, go-karts are a great idea.

Would love to see a family interactive educational center centered around Urban Ecology. NO MORE exploitation of animals please

A community garden would be amazing. Just nothing with animals please!

Please replace the Griffith Park ponies with a non-animal model! It is archaic and cruel to subject ponies of any age to have to stand the entire day and be forced to walk in endless circles with humans on their backs. Ponies can develop hoof ailments and many suffer from sore, chafed skin caused by ill fitting equipment. There are so many other forms of entertainment for children that do not involve animal exploitation.

It is 2023. We can do better!

Thank you,

[Redacted Name]
[Redacted Phone Number]

Please provide a space with forms of entertainment that do not involve the use or exploitation of animals. For example, I'd love to see go-karts, an inflatable obstacle course, put-put golf, water park attractions, etc.

Please choose a non-animal attraction for the space formerly occupied by the ont tide operation at Griffith Park. Any time animals are used for human entertainment it's invariably a bad (cruel) outcome for the animals. Let's not have to do this all over again. Please make a humane choice. Thank you for your time and consideration.

Please replace with go carts, non-animal fun, tricycle course, bocci ball court, pickle ball, bean bag toss

Please use go-karts or other non-animal activities in the park.

Comment

A dog park. We need more in Los Angeles. There are not sufficient options for pets and with many more people with dogs it is the best option. The dog park that is currently present next to soccer fields is almost unknown. Having one at the front of the park would allow for more visitors to explore the many options available. I just returned from Mexico City where there are more dog parks than in Los Angeles city. If a dog park isn't an option then a zen garden for reading as in Parque México in CDMX. This park has a small pond with flowing water, comfortable hanging chairs, a small speaker with low relaxing music and greenery surrounding a small circular area.

Please do not include live animals. We have learned too much to continue this practice.

Thank you for taking out the pony rides. They always looked so miserable and I'm sure they're grateful not to be forced to carry children in circles all day. I would love to see this replaced with something like bumper cars, or maybe a mini racetrack similar to the popular Cars ride in California Adventure or some other children's activity that fosters a love for nature, hiking or the outdoors. Again, I thank you and the ponies thank you.

Please provide a non-animal solution. There are so many out there that would set Griffith Park apart & ahead in entertainment, compassion & tourism. Use the savings from the pony upkeep to provide a more sustainable & employable opportunity. Maybe something like mini electric jeeps, trains, go-carts or other unique empathetic ideas that reflect our areas heart.

THANK YOU for discontinuing the use of ponies at Griffith Park. PLEASE replace that concession with something that does NOT employ the use of live animals!!! Hire a talented artist to create a fun activity for children that does not involve the enslavement of our fellow non-human animals. THANK YOU!!!

THANK YOU!!!! for cancelling this contract, and ending the abuse of elderly horses at Griffith Park! You did the right thing, and you will go down in the history books as being one progressive and compassionate city, that listened to the will of the people, and set an example to other cities that riding elderly over-worked horses, and other animals, is not entertainment and not something humans being should do in the year 2022. It belongs in the past, and that is where it should stay! So THANK YOU!! You are awesome!!! would like to commend you again for ending the pony rides at Griffith Park! As opposed to what the equestrian industry is trying to tell you now, riding a horse or a pony is NOT recreation, it is NOT fun for them, and it is NOT proper "interaction with animals" for children or a way to teach them about compassion to animals! Sitting on an animal's back for 8 hours a day is not fun for them, and they were not put on this earth to do this job for us! There are other ways to teach children about animals, and to let them interact with them in a safe and healthy way, and those are: animal sanctuaries! That is what they do, and there are 10 of them all around LA! (Such as Kindred Spirits Care Fram, Farm Sanctuary, The Gentle Barn, Saving Grace Animal Sanctuary, and others. I can provide you with a list). So those are places where animals are cared for properly, and where no animal is used or abused in any way, and where children and families can come interact with the animals! So let's leave that for them, it's not the job of Griffith Park to do that. A park is a park, and people can enjoy it without using animals.

So... let's keep the good work you have been doing, and not go back to another concession that relies on, and uses, animals. Time to let this practices go and leave them in the past! Otherwise, you will be un-doing and undermining everything you have achieved, and we all have wasted our time. so if you absolutely HAVE to have another concession there, please choose something fun that doesn't involve animals, like go carts, inflated bounce park, theatre performances, etc. Again, there are many forms of entertainment and enrichment for children and families, that do not use animals.

Thank you so much!

Thank you for banning the ponies at Griffith Park. There should be family entertainment that is a non-animal model or perhaps a sanctuary for unreleasable animals to teach custodianship for animals. Thank you for banning the ponies at Griffith Park. There should be family entertainment that is a non-animal model or perhaps a sanctuary for unreleasable animals to teach custodianship for animals. I want a non-animal model for Griffith Park. How about something with physical activities for kids like go carts and trampolines. Something that does not exploit animals and gives families something constructive to do for their kids. You can have a coffee and snack bar and places to interact while monitoring your kids playing.

Thank you for shutting down the inhumane pony rides. Please replace them with a non animal model/attraction. Thank you.

Ponies are antiquated. You should see that "grandfathering" them in means that antiquated traditions are not in line with modern society. The thought sounds like "oh pony rides, how cute" the reality is that it is a BUSINESS and profits mean there are issues in the care and well being of a live animal. Period. Hay belly from poor nutrition, abuse from humans that do not the highest quality of care and frankly, little kid's get HURT when animals have had enough. Put in some slides and merry go round and make it an animal free park and then there will be no controversy. The times for animal acts are changed. Period.

In regard to pony rides at Griffith Park, they are cruel. Children are just as happy to ride a buggy with lights and sounds. Buggys do not suffer in heat and get sub par care that makes us concerned and unite to call attention to it. Would we be here right now if these were mechanical rides? No. Make mechanical ponies and then you get the best of both worlds and no controversy. Get with the times. If you have to allow it to go on because it has always been a tradition then you should understand there are plenty of traditions that have needed to be railed against like slavery. Some things are bad but people want you to believe that since it is a tradition it is ok. It isn't.

Although I think pony rides are a great introduction to horses for many kids, this particular park doesn't keep the animals well-being in mind. Please try a go cart experience or some other form of entertainment and not further the abuse of these kind creatures. Either that or be an advocate for animal husbandry and teach horse care PROPERLY.

Please please replace the Griffith pony rides with healthier humane active children activities such as bounce houses, go karts etc. Ty for consideration.

The Griffith Park pony rides are sick and cruel. I advocate for animals and what I see is cruel and inhumane. The animals are ridden in 90 degree weather, some are lame or sick, most are too old. This practice needs to be banned.

Pony rides are cruel. Those animals do not look healthy. Put up park rides and actual activities that will have the kids moving around and not sedentary. I saw a video of a pony freaking out with a kid on it and it was not a pretty sight. No more pony rides!

Please replace the Griffith Park and Pony Ride with a non-animal model such as go-karts. Thank you!

Please don't use animals as entertainment ever at your park. Bounce houses, sports activities, music/dance, outdoor art, etc would be excellent. Thank you! Animal abuse & exploitation are unacceptable in all forms.

An obstacle course or mini golf would be great. Please provide a model that doesn't involve animal exploitation. Let's teach kids that animals don't exist for our entertainment.

You don't bring back an injustice that's been eradicated. Imagine human slavery being brought back? That would be repulsive and disgusting. Animals are not here to be anyone's slave and pull people around. Animals are not vehicles. Animals are not sources of entertainment. Who cares what people have been doing for decades. I'm sure during human slave liberation, they made similar claims. "Oh, our family has had slaves for many years". So what!!! It's about the rights of the individual. Not the feelings of the oppressors. Leave those ponies alone and tell people to entertain themselves. <https://youtu.be/qGly3Nr7-8o>

Please do the ethical thing and replace the Griffith Park Pony Rides with a non-animal model of family fun. To see these ponies being used as a source of entertainment is heartbreaking and unbearable. We can come up with creative ways to have family fun without abusing animals.

Please replace the Griffin Park and Pony Rides with something not using animals like go carts or something...PLEASE!

Please make the right choice and replace the Griffith Park and Pony Ride with a non-animal model. There are so many less harmful attractions you can choose such as mini train rides, go-karts, a skate park, the alternative kinder options are literally endless. Thank you

Please replace the Griffith pony rides with healthier, humane active children's activities, such as bouncy houses, go karts, etc. Thank you for consideration.

Progressive action requested ... Go-karts are good to use, rather than encouraging the exploitation of animals for entertainment. Thank you.

How in the world are people demanding to bring back this slavery? This abuse, this torture, I bet if it was them forced to carry people around all day every day for no pay they wouldn't like it, smh, this is what we are up against, selfish, egocentric animal abusers, ban all horseback riding and carriages, ban all animal abuse.

When I was growing up my Grandpa would put a quarter into the slot after he helped me climb up onto the pony. And I would go for a ride. It would only last a few minutes, but it made me happy. It didn't matter to me that the pony wasn't real. In fact, it didn't even occur to me. What mattered was that I was there having fun with my Grandpa. So there's really no need to exploit living beings! If I could be made happy on a plastic pony that rocked back and forth for a couple minutes when you put quarters into it, other kids would be too!

Please replace Griffith Park Pony Rides with a non-animal model. These poor geriatric ponies were abused, neglected, and exploited! The ponies had NO medical files for their health.

Some were lame, in pain with arthritis and could hardly walk, but we're still hit, clapped at, spooked, and yelled at to keep moving with the load on them in the drenching 98° heat!

Please don't let this be replaced with more ponies. Ponies lovers WILL be back if this happens! Do the right thing! A hands on Science center should replace this venue! Thanks!!!

Please replace the Griffith Park and Pony Ride with a non-animal model such as go-karts. Thank you.

Comment

Pony rides are totally unnecessary. We are facilitating abuse of animals and teaching kids it's ok to abuse them. This is coming from a mom. Please don't abuse or teach kids to abuse animals.

Thank you,
Neetu

Please, replace the rides with something more active for the children - a fun challenging playground with many slides, go karts, mechanical ride ons, a rope park

Please replace the Griffith Park and Pony Ride with a non-animal model such as a go kart or an inflatable obstacle.

Please replace the inhumane Griffith pony rides with other options for children such as bounce houses, and other fun activities that do not involve the exploitation of animals.

Please replace pony rides with a non animal model so the animals are no longer forced to carry humans.

Hi, my name is Joseph and I'm concerned that you may bring pony rides back to the park. I was so glad to hear that you'd let the contract with pony rides expire. What do you think about some of these alternatives?

Bounce house? Ball pit? Foam pit? Trampolines? Immersive Virtual Reality experience to showcase animals living in natural habitats across the world?

Please use a non-animal form of entertainment / education, however you choose to reimagine this space of Griffith Park

Please end using ponies at Griffith fair and instead have go carts, or a climbing wall (where someone is tethered of course!) Thank you!!!

I would prefer to see other fun options for the family such as go karts

I thank you for not renewing the pony ride contract at Griffith Park. Growing up in Los Angeles, I got to ride the ponies once or twice. If I would of known they were being overworked, geriatric and abused, I would of not ridden them. I think most of us didn't ever think it was an issue because humans don't think of animals as having rights. We see them as food or for us to own as property. It's time for ignorant traditions, heritage and whatever other word abusers stand behind. I do not want to see anymore live animal rides or petting zoos at Griffith park. Or an amusement park. We need to respect the wildlife that is currently living in the park. Their habitat needs to be respected along with the Los Angeles river where birds roost. The best solution would be to have the first and best urban wildlife education center. Similar to the P-22 festival that has the LA natural history zoo educate about local fauna and flora. Thank you for taking my comment.

Replacing the pony ride with a non animal feature would be great. How about those old fashioned carousels with imitation horses. They look beautiful and are quite exciting for kids.

Perhaps a tiny bumper car ride too. So much fun and if you make the little cars big enough a parent can sit in with the child too.

Please replace the Griffith Park and Pony Ride with non-animal games and activities, such as go-karts, inflatable obstacle courses, FUNBOX. Thank you.

Those ponies are in 95 degree heat, fed a substandard diet, have wounds, injuries, and get slapped and smacked and pushed to move.

Please use a non-animal model; great ideas can be go-karts, inflatable obstacle courses, etc which can replace Griffith Park and Pony Rides and Petting Zoo."

Something that doesn't include animal cruelty.

i think it's incredible that pony rides will no longer be taking place at Griffith Park!! some family-friendly, humane alternatives could be e-carriages or animal shelter adoption events! :)

Stop this!

Definitely support closing the pony rides. Animals shouldn't have to suffer for human entertainment. You can design an obstacle course in its place.

Please consider a more compassionate and fun for all species activity. Pony rides are cruel and unnecessary in 2023.

I am NOT in favor of bringing back pony rides, which are inherently abusive and are banned in many areas. Kids and families would be much happier with the type of mechanical rides you'd find at amusement parks. Go carts, bounce houses, teacups for little kids, carousels, live bands, and dancing competitions are all much more fun and cruelty-free.

Thank you for not allowing pony rides. there are plenty of other things that are entertaining without having to base it on animals. Thank you.

I'd love a ropes course with a rock climbing wall or a living museum (endemic wild plants that attract animals) where people of all ages can actually learn from and enjoy nature.

The cruelty of using equines for the purpose they have been used at this public attraction is well established and very clear. The track record of animal welfare is poor. It's time to bring Griffith Park into the 21st century with animal free (cruelty free) versions of entertainment for visitors. No more excuses, please make it happen.

Thank you for discontinuing the pony rides at Griffith Park. I urge you to replace the pony rides with ANYTHING that does not involve animals. I don't care what it is, but there are multitudes of good ideas out there that don't involve forcing animals in captivity to provide entertainment to people.

The equestrian community will try to fool you by talking about private horse ownership and how their horses love to be ridden. They're trying to pull a bait-and-switch of ethics on you. Now if people want to ride horses, and they keep and take good care of their animals that is one thing. But that's NOT what we're talking about here. Any BUSINESS that PROFITS from the use of animals is another thing entirely. So please don't be fooled by human supremacists when they say idiotic things like "Animals like to have jobs." Because if you do not have a mutual agreement of terms, and the ability to consent, i.e. the ability to QUIT whenever you want and walk away, that is NOT a job. So then, what is it? I would direct you to the dictionary to find the appropriate word for this kind of non-consensual "labor arrangement." (Hint: It's under the letter "S".) We as human beings should be better than this. We ARE better than this.

The City of Los Angeles has always been a guiding beacon of progress toward a world based on fairness and equality, always paving the way and setting an example, not just for other cities but for the whole world. While many people still don't recognize that all sentient beings deserve the same respect we give to cats and dogs, this is rapidly changing. There is an awakening happening. People everywhere are starting to realize we humans can't just do whatever we want regardless of the harm and suffering it causes to others, and then expect there to be no consequence. (Hopefully enough people wake up in time before this whole ecosystem is damaged beyond repair—but that gets into a larger conversation.)

I hope the City of Los Angeles knows that the number of people who care greatly about the wellbeing of our non-human co-earthlings is ALWAYS increasing--never decreasing--and that going into the future, ANY business enterprise that uses animals for human entertainment will ALWAYS be fought by people who value Justice and Liberty for all, until such enterprise is DISMANTLED AND DISCONTINUED PERMANENTLY. (All caps here is not to convey anger but for emphasis, so you understand this growing movement is not something you or anyone can make "go away.")

Please replace the pony rides with something that doesn't involve animals. Anything else means you will come down on the wrong side of history when people look back on these times. I know you're smart enough to know what the right thing to do is. You've already done it once by discontinuing the pony rides. The only question now is whether or not you have the courage to follow through, and make sure you don't replace one animal abusing business with another. The only way to ensure that is to stay away from anything that uses captive animals at all. It's actually quite simple when you look at it objectively. Thank you for reading. If any part of this message resonates with you, please share it with others and have an honest conversation about it. Because that's the only way we make the world a better, safer place for everyone. That which we do or allow done to the most vulnerable and powerless among us, those choices are what define who we are.

Re: Pony Rides- I think plans could have been made to improve the situation rather than closing the complete thing down. That was a hasty decision. It could have been improved and fixed.

Comment

Hello, I was very disappointed to learn that LA would close the pony rides. This was one of very few affordable opportunities for city children to get an experience with riding horses, something that is normally reserved for the ultra rich, and hard to even find in an urban area like LA. My daughter absolutely loved it and from what I observed visiting many times, the ponies were well cared for. I wish improvements could have been made where needed rather than a total shutdown. But the decision is past. I hope the park will continue to provide a special experience with animals and nature. I used to live in Berkeley where they have a farm in Tilden park with cows, pigs, sheep, ducks and bunnies. It is free to the public and you can bring lettuce or celery to feed to the cows. Perhaps something like that, an easy accessible experience to get up close and interact with farm animals (something a bit more real and larger scale,, not just a petting zoo) could be offered. I could imagine fun programming around a farm theme and maybe also opportunities for older children to volunteer and help with care and upkeep. Take a look and reach out to the farm at Tilden park for more ideas and inspiration. Thanks for taking input and hope to get to enjoy a new experience for my kids in the near future.

Is there anything that can be done to bring back the pony rides? Surely this can be done in an ethical manner. The pony rides are such an important tradition for Angeleno families. Griffith Park Pony Rides (GPPR) is a HISTORIC place in Griffith Park. It was a cheap place where low income city kids could experience, ride, and come to love horses. It provided a long-standing, valuable service to the community, and made ponies available to kids whose families would otherwise not be able to afford equestrian lessons. I myself have fond childhood memories of the ponies and grew to love horses and riding them through our National Parks.

I denounce the decision of Jimmy Kim and RAP commissioners of not renewing the GPPR contract. It is evident that the ponies were well taken care of from the independent 3rd party equestrian expert, Dr. Rachael Sachar. Steve Weeks, owner of GPPR, has been complying with the recommended improvements Dr. Sachar indicated. The fact that RAP based their decision on poor vet documentation of elderly ponies being cared for in retirement and not reported evidence from equestrian experts reflects thin reasoning.

Shame on Jimmy Kim and the RAP commissioners for not seeking council from the Los Angeles Equine Advisory Committee on this matter. The need for impartiality has been fulfilled by Dr. Sachar. Not consulting with sources of information like the Los Angeles Equine Advisory Committee makes this a poorly informed decision. Not to mention anger your constituents.

I would recommend Jimmy Kim and RAP to not support the animal terrorists who prefer to have mechanical/obnoxious amusements and prove themselves naïve, unfamiliar, or poorly educated by requesting a Merry-Go-Round Carousel or Dog Park when Griffith Park already has those amenities. Bring back the Pony Rides and Petting Zoo so children can experience and come to love LIVE horses, animals, and nature.

I urge you to replace the Griffith Park Pony Rides and Petting Zoo with a non-animal model. There are many options to consider that do not involve harming and exploiting animals, including environmental education programs, recreational activities, and entertainment such as go-karts, obstacle courses, or a FUNBOX (an inflatable bounce park). Please take a stand for animals and make the compassionate choice.

Please...no more exploiting animals. There are numerous activities that can be offered to families that do not involve animals. Arts & crafts, a museum, games, just about anything that doesn't involve abusing animals. We are way beyond this in our culture now. "The greatness of a nation and its moral progress can be judged by the way its animals are treated." ...Gandhi.

I urge you to replace the Griffith Park Pony Rides and Petting Zoo with a non-animal model. There are many options to consider that do not involve harming and exploiting animals, including environmental education programs, recreational activities, and entertainment such as go-karts, obstacle courses, or a FUNBOX (an inflatable bounce park). Please take a stand for animals and make the compassionate choice.

I urge you to replace the Griffith Park Pony Rides and Petting Zoo with a non-animal model. There are many options to consider that do not involve harming and exploiting animals, including environmental education programs, recreational activities, and entertainment such as go-karts, obstacle courses, or a FUNBOX (an inflatable bounce park). Please take a stand for animals and make the compassionate choice.

As an animal lover and a resident of Los Angeles County, I urge you to replace the Griffith Park Pony Rides and Petting Zoo with a non-animal model. There are many options to consider that do not involve harming and exploiting animals, including environmental education programs, recreational activities, and entertainment, such as go-karts, obstacle courses, or a FUNBOX (an inflatable bounce park). Please take a stand for animals and make the compassionate choice.

PLEASE replace the Griffith Park Pony Rides and Petting Zoo with a non-animal model. There are many options to consider that do not involve harming and exploiting animals, including environmental education programs, recreational activities, and entertainment such as go-karts, obstacle courses, or a FUNBOX (an inflatable bounce park). Please take a stand for animals and make the compassionate choice.

I urge you to replace the Griffith Park Pony Rides and Petting Zoo with a non-animal model. There are many options to consider that do not involve harming and exploiting animals, including environmental education programs, recreational activities, and entertainment such as go-karts, obstacle courses, or a FUNBOX (an inflatable bounce park). Please take a stand for animals and make the compassionate choice.

I urge you to replace the Griffith Park Pony Rides and Petting Zoo with a non-animal model. There are many options to consider that do not involve harming and exploiting animals, including environmental education programs, recreational activities, and entertainment such as go-karts, obstacle courses, or a FUNBOX (an inflatable bounce park). Please take a stand for animals and make the compassionate choice.

I urge you to replace the Griffith Park Pony Rides and Petting Zoo with a non-animal model. There are many options to consider that do not involve harming and exploiting animals, including environmental education programs, recreational activities, and entertainment such as go-karts, obstacle courses, or a FUNBOX (an inflatable bounce park). Please take a stand for animals and make the compassionate choice.

I urge you to replace the Griffith Park Pony Rides and Petting Zoo with a non-animal model. There are many options to consider that do not involve harming and exploiting animals, including environmental education programs, recreational activities, and entertainment such as go-karts, obstacle courses, or a FUNBOX (an inflatable bounce park).

I urge you to replace the Griffith Park Pony Rides and Petting Zoo with a non-animal model. There are many options to consider that do not involve harming and exploiting animals, including environmental education programs, recreational activities, and entertainment such as go-karts, obstacle courses, or a FUNBOX (an inflatable bounce park). Please take a stand for animals and make the compassionate choice.

It is time we stop considering animals as our entertainment. There are so many viable options for the community that does not use animals.

I urge you to replace the Griffith Park Pony Rides and Petting Zoo with a non-animal model. There are many options to consider that do not involve harming and exploiting animals, including environmental education programs, recreational activities, and entertainment such as go-karts, obstacle courses, or a FUNBOX (an inflatable bounce park). Please take a stand for animals and make the compassionate choice.

As a proud, life-long Los Angeles native and a citizen of Los Feliz since 2015, I urge you to replace the Griffith Park Pony Rides and Petting Zoo with a non-animal model. There are many options to consider that do not involve harming and exploiting animals, including environmental education programs, recreational activities, and entertainment such as go-karts, obstacle courses, or a FUNBOX (an inflatable bounce park). We are all grieving the loss of our beloved P-22. Everyone needs to realize that ALL animals are sentient, unique, special, and have central nervous systems and the capacity for the full spectrum of feelings. Please do the right thing for animals and make the compassionate choice.

Animals are just trying to live their lives in peace and need you to be their voice. I urge you to replace the Griffith Park Pony Rides and Petting Zoo with a non-animal model. There are many options to consider that do not involve harming and exploiting animals, including environmental education programs, recreational activities, and entertainment such as go-karts, obstacle courses, or a FUNBOX (an inflatable bounce park). Please take a stand for animals and make the compassionate choice.

I urge you to replace the Griffith Park Pony Rides and Petting Zoo with a non-animal model. There are many options to consider that do not involve harming and exploiting animals, including environmental education programs, recreational activities, and entertainment such as go-karts, obstacle courses, or a FUNBOX (an inflatable bounce park). Please take a stand for animals and make the compassionate choice.

I urge you to replace the Griffith Park Pony Rides and Petting Zoo with a non-animal model. There are many options to consider that do not involve harming and exploiting animals, including environmental education programs, recreational activities, and entertainment such as go-karts, obstacle courses, or a FUNBOX (an inflatable bounce park). Please take a stand for animals and make the compassionate choice.

Comment

I urge you to replace the Griffith Park Pony Rides and Petting Zoo with a non-animal model. There are many options to consider that do not involve harming and exploiting animals, including environmental education programs, recreational activities, and entertainment such as go-karts, obstacle courses, or a FUNBOX (an inflatable bounce park). Please take a stand for animals and make the compassionate choice.

I urge you to replace the Griffith Park Pony Rides and Petting Zoo with a non-animal model. There are many options to consider that do not involve harming and exploiting animals, including environmental education programs, recreational activities, and entertainment such as go-karts, obstacle courses, or a FUNBOX (an inflatable bounce park). Please take a stand for animals and make the compassionate choice.

I urge you to replace the Griffith Park Pony Rides and Petting Zoo with a non-animal model. There are many options to consider that do not involve harming and exploiting animals, including environmental education programs, recreational activities, and entertainment such as go-karts, obstacle courses, or a FUNBOX (an inflatable bounce park). Please take a stand for animals and make the compassionate choice.

I urge you to replace the Griffith Park Pony Rides and Petting Zoo with a non-animal model. There are many options to consider that do not involve harming and exploiting animals, including environmental education programs, recreational activities, and entertainment such as go-karts, obstacle courses, or a FUNBOX (an inflatable bounce park). Please take a stand for animals and make the compassionate choice.

Please replace the pony rides at Griffith Park with a non-animal venue.

I urge you to replace the Griffith Park Pony Rides and Petting Zoo with a non-animal model. There are many options to consider that do not involve harming and exploiting animals, including environmental education programs, recreational activities, and entertainment such as go-karts, obstacle courses, or a FUNBOX (an inflatable bounce park). Please take a stand for animals and make the compassionate choice.

As a Los Angeles native born and raised, I urge you to replace the Griffith Park Pony Rides and Petting Zoo with a non-animal model. There are many options to consider that do not involve harming and exploiting animals, including environmental education programs, recreational activities, and entertainment such as a mini roller coaster, train ride, go-karts, obstacle courses, or a FUNBOX (an inflatable bounce park). Please take a stand for animals and make the compassionate choice.

Stop using animals for entertainment!

Please, no more pony rides. Those poor ponies suffer so much in the heat. Especially carrying the fat ass, morbidly obese kids. Thanks.

Thank you for not renewing the contract for Griffith Park Pony Rides and Petting Zoo. I kindly urge you to help teach children to respect animals as sentient beings by replacing the old concession with an animal-free form of entertainment that provides youth and families with an affordable and enjoyable experience. Thank you for your time and consideration.

STOP ABUSING ANIMALS PLEASE. HAVE YOU SEEN THESE POOR OVERWORKED PONIES?

I have lived in Los Angeles for forty years. I have raised my son, now 13 here. I do not support incarceration or enslavement of animals for human entertainment. I have never taken my son to the LA Zoo nor the Griffith Park pony rides. I deplore the exploitation of animals subjecting them to unnatural conditions that exploit them for human pleasure and entertainment. There is nothing educational about the LA Zoo -- except that it teaches children that people have the right to enslave and hold wild animals captive to be stared and squealed at by humans. Enough. Please cease to allow any new entertainment or exhibits in Los Angeles City property, and find ways to phase out / discontinue any that already exist.

Please provide only animal free entertainment in Griffith Park. Thank you

Please do not use any animals for any kind of entertainment it is wrong. maybe talk about planting a garden, or things related to nature, hiking or have someone come and speak about learning to have compassion for animals and why.. Or have someone come to talk about Climate and Environmental issues.

As a long time resident of Los Feliz and park enthusiast, I would urge you to commit to accept only animal-free forms of entertainment in Griffith Park. The park is an ideal place to let people experience wildlife in their own habitat- wild. Thank you for not renewing the pony ride contract.

No more pony rides!

Hello, as a long-term resident of Los Angeles and someone who understands that all creatures should be treated with kindness and respect, I ask that you only consider animal-free forms of entertainment to replace the pony rides at Griffith Park. Thank you.

Thank you so much for not renewing the pony rides. Our hope as a family is not to see animal related recreation. guided nature walks would be so fun for young and old. We also love seeing groups learning how to care for the environment through activities that care for the vegetation - learning and productive. Could there be an inclusion of Native American / First Nations people and their ways of life to garner mutual respect? Accounting concerts and children's live entertainment would also be great. Kindly alethea Jones and PK Hooker

There should be many choices for entertainment in Griffith Park which do not require animals.

Please NO MORE animal entertainment. Let's stop the abusive practices. Animals are not here to entertain us. Be a Solution.

Thank you for not renewing the contract. Now let's teach children to respect animals as sentient beings by replacing the old concession with an animal-free form of entertainment that provides youth and families with an affordable and enjoyable experience.

You need to stop the pony rides. they are a form of Animal cruelty and should not be allowed to continue

I am very happy that you are no longer using animals for entertainment at the park. Instead of using animals to entertain kids and their parents how about them a merry go around or any other form of entertainment not using animals.

Please only have animal-free entertainment!

Please stop pony rides at Griffith Park. 38 years ago I took my daughter there. And she didn't like it due to the sadness of the horses. It has never changed, just more sad horses without a life.

Animals should not be exploited for our entertainment. We should not be teaching the younger generations that it is okay to do that.

Thank you for not extending the contract for the live pony rides it is much appreciated. As you continue to strategize for educational activities for our youth remember that animatronics AI computer-based and fun motion based attractions are sufficient no live animals should be utilized in the future. Thank you.

I cannot express in words how happy I am to hear that the pony rides at Griffith Park were shut down! It stressed me out to see those poor animals laboring in the heat and extreme weather conditions that they had to endure. The people who ran it, did not express any regard for these ponies and I applaud you for stopping it once and for all.

Please seize the opportunity to provide an alternative that does not exploit animals and can enrich and provide children with educational entertainment.

Southern California is simply too hot most of the year for the safety of the animals. It's also heartbreaking to watch any animals exploited and trapped in torment. It makes me avoid the park all together. Animal free is the way to go. Thank you!!

Please accept only animal-free forms of entertainment for the space previously used for Griffith Park pony rides. Thank you.

I politely request that an alternative to the animal entertainment be provided in the park. The little ponies are tired and bored...something we attend to in our children, so let's extend that care to the animals. :) Thank you. Respectfully, Mary Nadler

Please accept ONLY ANIMAL FREE FORMS OF ENTERTAINMENT...STARTING NOW!

Thank you for caring.

Respectfully,

~~_____~~

PLEASE - No more animals as entertainment in Griffith Park. It's been HELL for those horses/ ponies.

Since your subcontractors clearly can't be trusted to deliver MINIMAL care, i.e., food, water and rest periods to any animal they want to submit to public use in our parks, and JUST AS CLEARLY, none of you can be trusted to oversee the subcontractors YOU hired, stop allowing ANY animals for use by the public to be allowed in our parks! Good management consists in CARING what goes on. Not one of you qualifies for that description, so just end any possibility of animal abuse by ending animals in our parks!

Thank you so much for not continuing this contract, it is the compassionate thing to do. Those animals don't deserve a life of lugging people around. Please do not replace this activity with another animal based activity. That would be one step forward and two steps backward. Thank you for your consideration.

As long as it doesn't involve animals, I'd be thrilled!

Comment

I own the non-profit called Coalition for Animal Compassion. I help ALL ANIMALS across the world. My main GOAL is to stop animal cruelty at ALL levels and at all places. I am cordially asking you to please stop your pony rides and all other activities that involve live animals. I understand children truly enjoy the pony rides, but please have the vision to see how much more joy they will have to know that they helped, but not hurt, all animals by the decisions that they helped others make.

California and Los Angeles have been leaders in animal protection. I would like to see that responsiveness to evolving understanding as to what constitutes abuse, be applied to Griffith Park as well. Pony rides and other forms of "entertainment" that deny other- than -human animals agency, basic needs and comfort or the ability to exercise their species - specific needs, are archaic. These archaic practices need to be permanently done away with. Thank you for your consideration.

Please offer Animal Free entertainment...It is NOT fun for the animals..Choose humane treatment over greed...

Please consider NOT having any animal entertainment at Griffith Park, especially pony rides, caged animals, or attractions where children and adults are able to touch living animals. Not only is this unsanitary and unhealthy, it puts ADDED STRESS on Animals being fondled and have people noisily talking in their faces and ears. Animals are much more sensitive with their enhanced senses, than people are. They react to things much more easily than people and these sounds, sights and touching can damage the psyche and personality of an animal for life, making it unruly or feral. Please let the City of Los Angeles lead the way in treating animals with KINDNESS, COMPASSION and SAFETY as they are entitled to. Also we need to make California and all of the United States a NO-KILL COUNTRY. The carriage rides in New York City which were extremely dangerous and abusive to horses have been stopped. Please think of other activities that would be advantageous to the Park and the City that

DO NOT

involve the Abuse and Use of Living ANIMALS. They deserve safe, secure and happy lives. To do less than that diminishes us as human beings. Serial murderers ALL start their lives abusing and killing animals. We could minimize and reduce possibly totally these heinous crimes if we treated animals with sensitivity, concern and PROTECTION.....This is something that has been proven but not put in use by law. We can start now by giving the STATUS of PROTECTION, CARE, CONCERN and SAFETY in order to make a better safer society for everyone.....and it starts with our treatment of the entire ANIMAL WORLD.

Please take this well-researched information to heart. We have everything to gain.....for us and for ALL ANIMALS!

Thank you.....

I'd like to see animal free activities such as batting cages, go carts, climbing wall.

Please! No animal live entertainment in Griffith Park. The park must do something to provide entertainment that is not abusive to live animals!

Please teach children to respect animals as sentient beings by replacing the old concession with an animal-free form of entertainment that provides youth and families with an affordable and enjoyable experience.

As a LA resident and grandmother, I thank the park for not renewing the contracts with companies using animals. It's a bad message to send to our kids that riding on the backs of animals is a form of entertainment. We can send a better message.

Please stop this cruel form of entertainment. Millennials and Gen Z consumers don't want this.

Please have entertainment that is animal free. Please have compassion towards those that can't speak for themselves.

When we sow compassion toward every animal from every species in every corner of this earth, we reap compassion for ourselves and others.

May Compassion expand.

I urge you to end the pony rides in Griffith park

I think other fun things can be put together for children. Maybe educate them on how to treat animals with compassion and kindness

Please provide only animal-free entertainment/recreational activities at Griffith Park. Any entertainment or activities involving animals demonstrates a cruel exploitation of sentient beings and is unacceptable in any public or private location. Thank you in advance for supporting a humane choice that will benefit both people and animals.

Please use only non-animal forms of entertainment in the parks.

Thank you so very much for not renewing the contract for the pony rides and petting zoo. I ask that you replace these with an animal-free form of entertainment that provides youth and families with an affordable and enjoyable experience.

Leave the animals alone and don't torture them... god sees everything..... karma will come to you

Thank you for ending the pony riding contract. It is vital that we recognize that these animals are sentient beings that are not there for our entertainment. I would therefore like to see this replaced with an animal-free form of entertainment that provides youth and families with an affordable and enjoyable experience.

Please don't include animals

First, thank you for not extending the contract for the Griffith Park Pony Rides. Using/exploiting any animal for the entertainment of people/children is morally wrong. Worse, it teaches children that animals are expendable and usable at our command and raises disrespect and insensitivity for animals. This must be changed.

While I understand how much children love horses, and ponies perhaps especially, I am however much heartened to learn that this activity will cease. It may be fun for kids, but I've little doubt that the animals themselves don't appreciate it much. So I simply wanted to thank those responsible for reaching this decision. Truly, Thank You!

Please end the animal "entertainment" at Griffith Park and teach kids that animals should be treated with respect just like humans should treat each other. Thank you!

I respectfully urge you to not replace the pony rides with yet another animal activity. Animals should not be forced to work for our entertainment. There are other ways families can provide animal interaction for their kids than exposing animals to work. You could expand the train route to include going into caves or up hills; arts & craft stations; obstacle courses. There are countless ways to provide education and entertainment for children and families that don't require animal abuse.

Save the animals

Please, please, please replace the pony rides with a form of entertainment that doesn't include animals. I have witnessed animal cruelty and abuse there several times. Even if you got another vendor, the venue is not fit for animals. There are so many options that would be better replacements. As a psychotherapist, I believe strongly that we need to teach our youngsters to not be cruel to animals. Animal cruelty is often a precursor to violent and antisocial behavior. Thank you for your consideration. I truly appreciate your kindness in this regard.

Animal free entertainment only

Dear Task Force,

As a Los Angeles resident, I'm watching this decision closely in order to determine where we stand, as a community. Are we self-centered barbarians who subjugate and abuse animals for our own "entertainment?" Or, are we compassionate, forward-thinking individuals who understand that using other sentient beings for our own purposes serves neither those beings, nor us. Please consider for this space an alternative to pony rides such as an obstacle course, playground, or community garden. As Emma Lazarus said, "Until we are all free, we are none of us free."

Thank you,

Comment

Good afternoon,
I would like to thank you, for not renewing the contract. Now let's teach children to respect animals as sentient beings by replacing the old concession with an animal-free form of entertainment that provides youth and families with an affordable and enjoyable experience.

Please let's move forward to a society without the need to abused or use animals as entertainment, this is the year 2023.

Thank you
██████████

First I'd like to thank the department for not renewing the contract. Now let's teach children to respect animals as sentient beings by replacing the old concession with an animal-free form of entertainment that provides youth and families with an affordable and enjoyable experience. Teaching children not to support the exploitation of innocent non-human animals is a step closer towards better humanity.

I've lived in and near Griffith Park for decades. Animals don't need to suffer for entertainment. Please stop this inhumane practice.

Let's teach children to respect animals as sentient beings by replacing the old concession with an animal-free form of entertainment that provides youth and families with an affordable and enjoyable experience.

Thank you for not renewing the contract for the pony rides. Live animal entertainment is not fair to the animals. Let's teach children to respect animals as sentient beings by replacing the old concession with an animal-free form of entertainment that provides youth and families with an affordable and enjoyable experience.

Thank you for ending the pony rides. Could the space be used for a sanctuary for rescued animals?

Hi, I'm writing to express my support for animal-free entertainment at Griffith Park and any other LA Parks and Recreation site. Let's teach our children that animals are to be respected and not used for our amusement. Thank you.

Leave them alone

Please don't allow animals to be used as rides or "entertainment" at Griffith Park. The days of pony rides have passed. Please have an ethical approach to developing the park without exploiting animals. Thank you.

I was very happy when the Pony Rides in Griffith Park finally closed down since I have personally witnessed on countless occasions the poor treatment of the ponies, lack of water and food, exposure to heat with no shade, having to work hours on end without rest.

In today's world many people have realized that using animals in any form of entertainment is really exploitation of the animals for the sole benefit of the company and never of the animals.

I hope I can count on you to never allow entertainment with the use of animals in Griffith Park or any other park in your jurisdiction ever again. The zoo is right there.

Respectfully,
██████████

Thank you for not renewing the contract of the animal abuse which masqueraded as "children's entertainment", the Griffith Park Pony Ride. And Petting Zoo..

There are many fun-filled rides, such as merry-go-rounds, go carts and mini trains which provide fun and entertainment for children and parents, while not degrading and abusing animals.

Please consider these in your plans for any future installation.

Thank you again for putting a halt to egregious animal abuse, which the majority of your constituents were firmly against.

Please do not use live animals at Griffith Park

With respect, may I please strongly suggest a NON-ANIMAL exhibition be introduced to take the place of the PONY RIDES which had been questionable as to their humane care of the animals for some years. Perhaps something educational involving gardens, the environment or climate. It is imperative that children learn to respect and protect those entities and while an involvement with animals is wonderful, the animals must be treated with the upmost care and protection from ALL potential harm, which the previous EXHIBIT failed to do.

Thank you!

I, along with so many people, would love to see a permanent ban and end of the pony rides. No more animal "entertainment" at Griffith Park. We need to show that we have a respect of the dignity of other animals, and to teach that to our children. Thank you for your time and consideration. Please do the right thing.

Comment

Hi, We want a non-animal model business at the Griffith Park. The Pony Rides caused so much suffering and unnecessary death to many of these beautiful, innocent animals that it has to be treated as criminal animal abuse and investigated. The people responsible must be punished not rewarded. We don't want animal exploitation in Los Angeles. There are many intelligent and creative ways to do business, animal exploitation and using animals is not a business it's a crime. No excuse for animal abuse. Please send the rest of the animals to accredited sanctuaries. Don't let the abusers decide the animals' fate. Thanks Parents are racing to get their kids injured even possibly killed at the Griffith Park Pony Rides, in Los Angeles.

We were told 2 kids were already dragged by the horses. Are they waiting for another kid to be injured to end this misery?

They are making money by abusing kids' love for animals. And setting a terrible, cruel example as adults.

It's child abuse and legalized criminal animal abuse.

Rangers complaining about an activist having "argued with some parents, next to their kids". Parents "worrying about their child's safety" due to an argument about compassion and safety??? If they are worried about their kid's safety then don't put them on any animal. Animals get scared and run off which may cause injury or death to the kids and the animals. There's no excuse for abuse.

Not doing anything to stop a possible injury due to using sentient beings as vehicles is neglect and a crime.

There are many other ways to have fun there without using animals. People already submitted great ideas. We want the animal exploitation to be replaced with compassion.

Animals are not vehicles, couches or things.

These ponies, horses and other animals at this facility must be sent to a proper sanctuary.

Horses don't even carry their own kids.

Horse riding is as absurd as riding a dog.

Get off animals' backs.

It's time Los Angeles and the world to end these archaic and barbaric entertainment models.

We want compassion and 21st century entertainment without using and abusing animals.

We want sanctuaries where kids can interact with and help animals, not places to contribute to their abuse.

Train the adults, not the animals.

Animals are not entertainment.

Teach kids kindness not abuse or violence.

Ban all entertainment that uses animals now.

Thank you

Please I would like the park free from animal cruelty, we can have different kind of entertainment.

Please don't replace the inhumane and abusive pony rides with other other forms of abusive, mindless entertainment for some thoughtless persons.

Please stop animal entertainment in Griffith Park. It's inhumane to force animals into recreational entertainment under these circumstances. No living creature should be forced into entertainment under conditions like this.

Please do not exploit animals for entertainment. Please furnish playground rides, etc, instead.

Those and mímala are mistreated overworked and deserve to have a better life. They can go to a sanctuary.

Thank you for not renewing pony rides. There's so many things for kids to do; Maybe playground type of things, or growing vegetables in boxed raised beds or something like open stage where kids. can present something Thank you again

Please do not use animals for entertainment

I urge the department to accept only animal-free forms of entertainment.

THANK YOU SO MUCH FOR CONSIDERING THE AGED PONIES AND NOT WORKING THEM ANYMORE. GOD BLESS YOU FOR SAVING THESE BEASTS OF BURDEN.

Stop exploiting animals!

Please consider all animal-free entertainment. Animals have been abused and exploited for far too long in the name of entertainment. If Los Angeles doesn't lead by example, not many cities will. Thank you for your time.

Please accept animal-free form of entertainment

The Griffith Park Pony Ride concession contract will expire on December 21, 2022. After careful consideration, the Department of Recreation and Parks (RAP) has decided not to extend the contract. Pony rides will therefore be closed to the public beginning December 22, 2022. At the request of the City Council, the Department will undertake a community input process to re-imagine the recreational and educational activities offered at this location in Griffith Park to continue providing youth and families an affordable and enjoyable experience.

We hope you will not allow live animals to be any part of entertainment or education in Griffith Park. Surely slide show, films, great speakers can help the public learn about and appreciate animals, domestic and wild, with whom we share the Earth.

Thank you.

How about creating a fun maze for the families to travel through, or some kind of activity that helps foster appreciation of nature?

Comment

Please provide safe, wholesome entertainment that does not involve the domination or work or petting of animals. We are all trying to move past these old days of roadside attractions and petting zoos where the bedraggled animals must stand and tolerate children's screams and unnatural interactions. There are robotic full-size dinosaur exhibits that kids LOVE! These exhibits increase attendance wherever they go. Please add educational components and teach children that animals are not here to serve and entertain us. Please!

If you're determined to involve live animals for some reason, organize rotating pet adoptions w reputable rescues who are vetted through the city. Or off-site adoptions with dogs from our city and county shelters. The shelters are equipped and prepared for mobile adoptions.

I work in animal rescue and have volunteered in the animal shelters for years. Children — and their parents! — desperately need to learn humane animal treatment. Please be open to new ideas. This is an opportunity to step up LA's game. I'm happy to help or advise as would many others in local rescue.

Thank you.

Animal-free entertainment for kids please, and no more animal cruelty for these poor creatures!!

Stop exploiting animal life please

An idea that doesn't involve animals used for entertainment would be great. Maybe an extension of the train or a playground?

Hey, why not put exercise equipment there. Burbank does that and it works out real well.

Please don't overwork these poor animals

We don't want or need pony rides. Stop the abuse.

Thank you for being on the right side of history and not renewing this contract and releasing these defenseless and voiceless animals from this misery.

I know this is quite a contentious issue, people saying what a shame to lose the pony entertainment they grew up with etc. But they are not considering that those ponies were *allegedly* mistreated in various ways. That is the great risk that any animal-related entertainment faces. Even under "good" living conditions, no animals should be made to work long, difficult hours providing entertainment. Some sort of hands on kids activities at all age ranges, learning more about the park's flora and fauna, even geology, could be fun.

Treasure hunt trail walks?

I am ecstatic that you are finally doing away with the cruel pony rides at Griffith Park and encourage you find other ways of providing entertainment for children that are not at the expense of the welfare of animals. These poor creatures don't have a say in what you are asking them to do - all for the sake of entertainment.

Thank you for not renewing the pony ride concession. I hope more folks take your lead.

First, thank you so much for not renewing the contract for pony rides at Griffith Park. Kids have so many activities to choose from these days, even if they're not the same ones as years ago. No doubt some reimagining will be needed, but there are plenty of fun and educational things to do in the world. It may seem that contact with these ponies is a positive thing, but how can showing children that it is ok to be cruel to living creatures be, in any way, a good thing. Thanks again for listening.

Thank you for not renewing the Griffith Park Pony Rides contract. Now let's teach children to respect animals as sentient beings by replacing the old concession with an animal-free form of entertainment that provides youth and families with an affordable and enjoyable experience. Please allow only animal-free forms of entertainment. Thank you.

Please no more exploiting these animals for money

Thank you for not renewing the contract. Now let's teach children to respect animals as sentient beings by replacing the old concession with an animal-free form of entertainment that provides youth and families with an affordable and enjoyable experience.

Any form of entertainment should be used with exception of live animals. Animals should not be in any part of entertainment use at all. Thank you

I would like to thank you for not using animal entertainment since it is cruel. I also urge you to keep the ban on using animals for entertainment purposes.

Thank you for not renewing Pony Rides and Petting Zoo's contract. Please consider only animal-FREE forms of entertainment to provide children and families with enjoyable time and educational experience to respect animals as sentient beings.

PLEASE OFFER ANIMAL-FREE ENTERTAINMENT

Thank you for not renewing the pony ride contract at Griffith Park. Animal cruelty for entertainment needs to stop and I really appreciate this step.

Please stop abusing animals in the petting zoo and donkey rides.

It's abusive and needs to stop.

Please no more animal entertainment

Please replace the old pony rides with an animal-free form of entertainment. Maybe go-karts or a state of the art learning center (for education on native plants/animals) or an obstacle course with a rock climbing wall?

I am very happy that the pony rides are discontinued in Griffith Park. It is too hot and it is a stressful environment for the animals. Please continue to keep animal events out of Griffith Park in the future. Thank you.

This is an outdated tradition, and reflects bad on Griffith Park. When I started taking my son in 2010 to ride the train, he was just a toddler, so he wasn't old enough to ride the ponies. But as we circled around on the train, we could see the stables, and the horses who were off duty. I noticed the conditions for these horses were not good. When my son was old enough to ask, he asked me why the ponies are sad. I knew at that moment we would never take part in this outdated and abusive circus ride. Bottom line, that's what it is. Please don't re-establish this horrible attraction. Just because people in their 30's to 70's look fondly on it, doesn't make it right. Griffith Park and Los Angeles is better than that. Those ponies were not taken care of, and that was obvious. It was just a depressing and sad attraction.

Please - NO animal entertainment events. Thank you

Please stop permanently the Griffith Park pony rides. Animals must not be exploited for human's temporary pleasure. Thank you.

Please do NOT replace the pony rides with more animals! How about some pickleball courts?

Hello, I am hopeful that this is a unique opportunity for the Department of Recreation and Parks to reimagine the recreational and educational activities offered at this location in Griffith Park. I do worry that officials may be considering animal entertainment options, and a decision could be made as soon as Thursday, February 16th. I respectfully urge the Department to only consider, and accept, animal-free forms of entertainment going forward. Now is the time to teach children to respect animals as sentient beings by replacing the old concession with an animal-free form of entertainment that provides young people and families with an affordable and enjoyable experience. A chance for learning and fun.

Thank you in advance for your time and consideration.

Please don't use animals for entertainment.

Hello, I am contacting you to thank you for not renewing the Griffith Park Pony Rides and Petting Zoo's contract.

I sincerely hope that you will accept only animal-free forms of entertainment in the future.

Please help teach children to respect animals as sentient beings by replacing the old concession with an animal-free form of entertainment that provides youth and families with an affordable and enjoyable experience.

I would really prefer we retire this operation. There are other activities in the park that can be organized for children.

Please, no animal entertainment at Griffith Park.

Please help stop animal exploitation

I urge you to replace the Griffith Park Pony Rides and Petting Zoo with a non-animal model. There are many options to consider that do not involve harming and exploiting animals, including environmental education programs, recreational activities, and entertainment such as go-karts, obstacle courses, or a FUNBOX (an inflatable bounce park). Please take a stand for animals and make the compassionate choice.

God will judge all men who acts against His innocent creatures, in the name of Jesus Christ!

Comment

Thank you for not renewing Griffith Park Pony Rides and Petting Zoo's contract. Please choose to teach children to respect animals as sentient beings by replacing the old concession with an animal-free form of entertainment that provides youth and families with an affordable and enjoyable experience.

Thank you for closing the contract. If animal interaction is a must, maybe there's an opportunity here to partner with local animal rescues to help find homes for the many cats and dogs in need around LA.
Please consider implementing only animal-free forms of entertainment so that the youth can still enjoy spending fun times with their families without having to do so at the expense of animals. Some examples of these forms of entertainment are mini-train rides and an outdoor playground and climbing maze with safety nets surrounding it. Thank you for considering my message, I appreciate that you value our input.

Please only consider a form of non-animal entertainment moving forward. It's critical that the community understand ethics in regards to the treatment of animals. Children are especially vulnerable to impression on how animals are used and treated. Animals are not ours to create entertainment for ourselves. Thank you-

Provide only animal-free entertainment only!

Thank you for not renewing Griffith Park Pony Rides and Petting Zoo's contract.

Please accept only animal-free forms of entertainment. Let's teach children to respect animals as sentient beings by replacing the old concession with an animal-free form of entertainment that provides youth and families with an affordable and enjoyable experience.

Thank you.

thank you, for helping them!!!

Thank you for not renewing the contract. Now let's teach children to respect animals as sentient beings by replacing the old concession with an animal-free form of entertainment that provides youth and families with an affordable and enjoyable experience.

As a society, we should have advanced to a level where animals are no longer required for our entertainment. Using animals opens the door to abuse as the animals cannot speak and tell us when they are hurting. Please provide safer and kinder alternatives for our children.

As an employee of Griffith Observatory and Griffith Park, I URGE you to leave the exploitations of animals out of your decision making process! Stop teaching kids that it's okay to hurt other living beings. Find some other activities to give them. Believe me, it's not hard entertaining kids.

Dear Leaders: I am a constituent and long time resident of West Los Angeles. Please consider a non animal model for the next concession in Griffith Park. As you know, the previous Pony Rides caused many problems, such as children's safety issues and death of several ponies. It also created negative publicity and public relations issues for the Park and City. Instead, choose a non animal model that will provide fun, exciting and educational activities for children and families. Thank you so very much.

Please accept only animal-free forms of entertainment!! It's sad that I even have to ask!

No animal should be exploited and forced to do something against their will. Please do not replace the next entertainment involving animals. Geez no more.

Thank you for not renewing the contract. Now let's teach children to respect animals as sentient beings by replacing the old concession with an animal-free form of entertainment that provides youth and families with an affordable and enjoyable experience.

A five minute ride on a half dead animal will not teach children who have never had exposure to ponies what the animals are really like. As far as the children are concerned, they're riding an alternative to merry ground horses.

Their parents, let alone, small children, have no idea that this is not what ponies are really like.

An interactive children's museum might be a better alternative. If the children had a chance to go to the country and see the ponies with their heads up, trotting around, and they had to feed and groom them, that might give them an idea of what the ponies are really like.

Overheated, saddle sore, dehydrated ponies with no chance to graze freely is an exposure to how to torture animals, not interact with them in a positive educational manner.

Therefore, I very highly recommend that no animal alternatives be provided. If the equestrians want to take these children to their ranches and let them ride their own horses, let them. At least those horses are taken proper care of.

Is there any plans to re-open this?

Thank you for not renewing the pony ride/petting zoo contract. If possible, please replace them with an animal-free form of entertainment that provides kids & families with an affordable and enjoyable experience. Thank you!

I believe there must be a way to provide pony rides to children in a humane way for the animals. I grew up riding the ponies at Griffith Park. I took my kids. Please do not let extremists take away an important traditional activity associated with growing up in Los Angeles

Move the carousel with building and put in place of the pony ride

Please accept only animal-free forms of entertainment and stop supporting animal cruelty !

Please animal-free rides or entertainment. End the suffering

This decision to shut down such a historic icon is disgraceful! People have been bring their children there for over 60 years! I am outraged and will do what ever I can to fight against what ever group of evil people came up with this. Los Angeles has gone down the toilet due to leftism policies. I wouldn't be surprised if this too had something to do with some illogical political reason. Sickening

Animals are not entertainment

I am disappointed and dismayed that a small vocal group has caused the wonderful pony rides to end. I took my daughter and son there when they were little many times. It was so special. The pony staff were careful to limit the weight on the ponys. They were kind to children and animals.

My grandchildren were in town last week. We went to Griffith Park and were so sad to see the empty space. They did enjoy the train, but we always did both.

I was born in Los Angeles, and lived most of my life here. Why should we let a small group make our wonderful Griffith Park less than it was?

We are so sad that the pony rides have been 'cancelled' - there must be a way to ensure quality of life for the animals while providing a positive encounter and enriching experience for the children of our city. Please find a way to bring back the ponies and petting zoo!

Would like to see pony rides back and more kids activities

Comment

Greetings,

First please accept my appreciation and respect for shutting down the pony rides at Griffith Park.

Between the extreme heat, the lack of fresh water, saddle sores, lameness, overwork, use of geriatric horses, foot, mouth and tooth problems, and the utter torment of walking in circles all day, the horrific torture that these helpless trusting ponies were subjected to has finally ended.

In addition to the lack of care and the torment of the ponies, children were in danger from the rides, this was caught on video, a child was dragged around because the proprietors of the pony rides cannot be bothered to ensure that the saddles are working properly.

There are many entertaining and profitable ways to utilize the space formally occupied by the pony exploitation. Mechanical rides like merry go rounds, mini golf, radio controlled mini boats and cars, trampolines, things for kids to jump around in, and more.

So many options that are not only cruelty free, but also much more engaging for youngsters than being mindlessly carried around in a circle by a tired and thirsty pony.

Please stay strong and do not reinstate the cruel pony rides.

Thank you for your kind attention

Thanks for being open to allow the public to give feedback to express what the possibilities are for the future of this location. If there was something of an animal sanctuary in which children and adults could interact with animals and plants that teaches harmony with nature, instead of benefiting from it. The space would serve not only to educate, but also provide a deeper connection with other sentient beings.

During the time that my daughters used the services to ride a Pony, never we saw the workers do something wrong or be neglect with the horses. We hope they come back to bring this services again.

My 6 year old daughter very much liked the pony rides. She feels robbed of the opportunity her older sister benefitted from. She never made it to the fast ponies. And she wishes she lived somewhere where the pony experience exists.

Her older sister, now 13 years old, very much enjoyed the pony rides when she was younger. The older girl was proud to advance from slow to medium to fast ponies. In fact, she has taken a week of horse husbandry and trail riding summer camp, each of the last few years.

Please bring back the ponies.

Please bring back the pony rides! This is the only affordable way for children to experience horseback riding in LA. With the removal of the pony rides, only wealthy children will be able to experience the joy of riding a horse meanwhile the "regular" kids are stuck with nothing. It's absolutely unfair and discriminatory to discontinue this amazing LA tradition.

Please bring the pony rides back. My kids were devastated when they found out that it is been closed. I have been ringing them here since they were 2 years old.

I am shocked and saddened to hear about the pony rides closings. Please bring the pony rides back to our community as this was something that all the children really look forward to and enjoyed. Escape them an opportunity to be outdoors and not in front of screens. Bring the pony rides back!!!!

I am 9 years old and I have been coming here since I was a baby. Today was spring break and my mom tried to bring me here and we realized that the pony rides is closed. Such a sad day. Please bring the ponyrides back. We missed the pony ride very very very very very very very very very very very very very very very very very much. Thank you! Crying

Hello there, I have two questions regarding this topic - where did all the ponies go?

Are they still available to rent for a birthday party? Thank you very much

Pony rides should come back!

What will you be replacing pony rides with?

When is the next recreation and commission task setting up the next community feedback session to get public opinion on what should happen with the former pony ride location? I would like to participate.

Why did you take one of the most popular things that kids can do on the weekend and close it? It is unconscionable. The ponies were better cared for at Griffith Park than most places. You listened fake animal rights activists who knew nothing and were only there to self-aggrandize themselves. Shame on you. Reopen the amazing experience.

Hello I am A 20 year resident of Los Angeles City. Throughout the years we have enjoyed using Griffit park. One of the best part of it as i myself and my kids my family members were coming here to enjoy pony rides animal in general. After the animals are gone my kid lost interest in this place, and there are not much options for us to choose from. I am writing this in hopes that we can have the ponies back and start coming back and see the jo in my kids eyes again. Thank for your time

Greetings: I am semi local, Orange County, but grew up in Los Angeles, specifically Los Feliz. All of my life, since I was old enough to ride, the ponies were and still are a part of me. I took all 3 of my daughters as well to the ponies for years. And I recently, took my 90 year old father, to the last day the ponies were operating.

We are in full support of keeping/bringing back the pony rides, as the lifetimes of experiences and memories to be taken away for all the young children today, would be an injustice to Los Angeles, the children, a simplicity in upbringing. We need to find a way to keep the ponies there.

We have heard many stories regarding treatment of the ponies, and though we can't confirm or deny, we can say that we do not believe these rumors and accusations. We witnessed first hand the activists and protestors who were standing their ground at the park, and believe with all of our hearts, that these people are confused, mixed up, and advocating for the removal of something they have little to no knowledge about. And have little regard for anything outside their own realm of thinking

With the current vendor being removed, there is great opportunity, regardless of the inaccuracies of the accusations, to find a new vendor as well, if the old one isn't regarded highly. Though I believe he/they were.

Though our world is ever changing, places like these must be kept and preserved, not just as part of our history, but to give to our young children, experiences that they are being robbed of in modern times. We simply must not erase everything good due to a group of people that either do not know what they have missed, may possibly be from outside the area, or simply just have an agenda, and/or give in to a Ranger(s) that from our understanding took no public viewpoint from pony advocates in his/their decisions. Eliminate the ponies in our opinion is truly a tragedy in so many ways as we will lose such a beloved part of Los Angeles and the gift of simplicity and animals to our children.

Save the ponies and give our children a world of wonder.

My daughter still asks if she can go see the ponies & pet the goats. We were so saddened & heartbroken to hear this was shutting down & went the closing day. We were regulars. For kids growing up in a big city like Los Angeles it was invaluable to give them the learning opportunity of seeing farm animals in person & especially at such an affordable rate. To get a similar experience we have to drive an hour away. Not to mention this was an LA institution. We have home movies of myself riding the ponies when I was 2 years old. Disappointed in our city & leadership for this decision of caving to a couple animal rights activists. Let's prioritize our kids & think of their benefits instead of what domestic livestock are bred to do.

Our neighborhood council opposes your decision.

Comment

Greetings, First please accept my appreciation and respect for shutting down the pony rides at Griffith Park. Between the extreme heat, the lack of fresh water, saddle sores, lameness, overwork, use of geriatric horses, foot, mouth and tooth problems, and the utter torment of walking in circles all day, the horrific torture that these helpless trusting ponies were subjected to has finally ended. In addition to the lack of care and the torment of the ponies, children were in danger from the rides, this was caught on video, a child was dragged around because the proprietors of the pony rides cannot be bothered to ensure that the saddles are working properly. There are many entertaining and profitable ways to utilize the space formally occupied by the pony exploitation. Mechanical rides like merry go rounds, mini golf, radio controlled mini boats and cars, trampolines, things for kids to jump around in, and more. So many options that are not only cruelty free, but also much more engaging for youngsters than being mindlessly carried around in a circle by a tired and thirsty pony. Please stay strong and do not reinstate the cruel pony rides. Thank you for your kind attention,

Dear Commissioners,

We, the members of the Griffith J. Griffith Trust, urge a reconsideration of the decision to end the Pony Ride concession in Griffith Park. For three-quarters of a century, it has been an accessible and

affordable way to introduce children to the equestrian world.

One can only imagine the anticipation and excitement of children from across the Los Angeles Area converging upon the Griffith Park Pony Rides. For some, it is carrying on a family tradition, as the

Pony Ride concession has been an integral part of the Griffith Park experience since 1947. How many Angelenos have photographs and memories of several generations of family members riding the ponies across the decades?

For others, the Pony Rides are a way for children from less-affluent families to sample a lifestyle that might otherwise be closed to them. Col. Griffith J. Griffith meant for his park to be a refuge for the "plain people." The affluent will always have stables, many outside the city, to take their children to for a significant price. The Griffith Park Pony Rides-along with Shane's Inspiration a mile or so down the road-are notably inclusive children's attractions, accessible by public transportation.

We also want to point out that Los Angeles Historic-Cultural Monument #942 designates the Griffith Park Pony Rides as Item #4, a contributing element for its city designation. As such, it is worth fighting for-but not without change.

We are not blind to the concerns of those in opposition to the Pony Ride. We are not in favor of maintaining 1947 standards of animal care and welfare. But we are sure that similar attractions are

in operation in other cities that follow contemporary standards. We urge Recreation and Parks to adopt those state-of-the-art standards and find a concessionaire willing and able to live by them.

Why are so many amenities for underserved children closed at Griffith park ???

Please request a RFP for the pony rides as soon as possible !!! It should have never been closed in the first place.

Fix the plunge pool! Open the merry go round!! Fix the Griffith park Fountain!!!

What is going on ???

Hello,

I was on the list at today's 8:30 AM meeting to speak regarding the pony ride venue via my phone number 818-515-3916 and could not get the volume to work on my device. So I send this email in the hopes it is shared.

I am a nurse and animal lover who is in favor of keeping pony rides at Griffith Park for the children and families of Los Angeles. I grew up in Los Angeles and a love of horses was initiated with pony interaction as a child. Horses have definitely enhanced my life.

I visited the park over three days during the last week of the venue's operation and spoke with activists, horse lovers, employees, and patrons who were there.

The activists I spoke to knew nothing of horse care, conditions, or life expectancy. Ponies die in sanctuaries as well. One activist said she was against owning animals of any kind and another, a man, said parents should just take their kids to Disneyland. He did not know the cost. A dad stepped from the line and asked this man "do you have children?" and the answer was "no."

There is no comparison to the experience of an amusement park vs a pony ride though. The pony rides being out of doors in the beautiful Griffith Park setting and affordable to the community at large was very special. I saw an endearing group of five boys in cowboy boots making their way to a birthday party and talked to a mom who brought her daughter regularly to ride her favorite pony.

The patrons who come for this type of interaction are not going to come for a mechanized activity. This was a beloved experience spanning generations and I think sadly of its demise. It fostered a connection with nature and animals. That connection has just lost another link with the closure.

I think the vocal minority (activists against) has swayed the commission who don't want to deal with dissention. If I am mistaken, please correct me.

Sincerely,

~~XXXXXXXXXXXX~~

Dear Public officials,

Please RFP pony rides ASAP! Isn't this the usual process to obtain another pony Concession? Why is this a long drawn out process ??

As a public official, you should be listening to the majority of LA residents and not the minority who are outside LA extremist.

Fix this disaster you have created with an RFP for pony rides immediately!!

Thank you.

Dear Los Angeles Recreation and Park Commissioners and Executive Team,

I am calling upon your resignation for allowing ongoing animal abuse at Griffith Park and Pony Rides. It is egregious that you're allowing for this park to remain open when Stephen Week is in violation of the law and his current contract.

Resign immediately. You're providing a disservice to all Angelenos by excusing animal abuse! You pass inspection reports when laws are being violated, you don't answer public act request, and you're allowing for a concessionaire to operate when he is in violation of his contract.

Every single one of the animals at Griffith Park need to be at a sanctuary, immediately!

Dear Recreation and Park Commissioners Recreation and Park Commissioners,

As a Los Angeles resident who cares about the wellbeing of animals and an In Defense of Animals supporter, I urge you to stop animal suffering in your district by eliminating the Griffith Park Pony Rides and Petting Zoo's contract, replacing Griffith Park with a non-animal model and sending all of the animals to a sanctuary.

For five years, your agency has passed inspection reports for the concession, while the owner Stephen Weeks has been breaking California Health and Safety Code 25998. Elderly ponies and horses at Griffith Park Pony Rides have documented depression. Spot the pony has lameness, yet is forced to carry people on his back.

Recently an overweight sheep was in distress with no worker attending to her needs, and many horses and ponies were itching due to their halters, which appear to be on all the time. Elderly ponies and horses were also seen being hit and chased for almost eight and half hours on the weekend.

No amount of improvement will ensure that these animals are not suffering from depression. Independent equine expert Rachael Sacher DVM, CVA reported elderly ponies working with saddle sores, elderly ponies with no dental treatment, no identification methods for any of the animals, and an elderly pony with a fever undetected by this concession while your department and Stephen Weeks make millions off the backs of these elderly ponies. Griffith Park Pony Rides pays Recreation and Parks a revenue-sharing fee of 25 percent of their gross income, and as a Los Angeles constituent, I oppose city funds generated from animal abuse.

Pony rides exploit animals for amusement and profit. This practice teaches children the wrong lessons about animals as objects for amusement instead of appreciating our animal neighbors as sentient beings.

This concession also poses a risk to children. Last year, a child was reportedly dragged by a pony after her saddle slipped, and the pony continued dragging her body because the pony was spooked.

I respectfully request that the pony ride contract be canceled rather than renewed. Please undertake a study to consider alternative proposals that are generated from a non-animal model for the site that would engage children and families. Lastly, I urge you to send all of the animals to a sanctuary, which advocates have already arranged and confirmed.

Thank you for considering the well-being of animals in our community. Please make compassionate choices to improve the quality of life for our animal neighbors.

Sincerely,

~~XXXXXXXXXXXX~~

Comment

Dear Commissioners -

I am writing to express my feelings and opinion regarding the Griffith Park Pony Rides. It would be an injustice to fail to renew or extend the contract with Mr. Weeks to continue to operate this long-standing (73 years!) operation. The pony rides have provided joy and exposure to ponies to generations of children who would otherwise have no such experience. Mr. Weeks provides excellent care of both the currently used ponies and the retired ponies, who live out their lives in the same location and with no disruption that would cause them distress. Mr. Weeks has even hired a welfare officer to ensure the proper care is given to these ponies.

The extremists who have been protesting the pony ride operation have threatened Mr. Weeks, his employees and even the parents who have brought their children to enjoy riding the ponies. Members of this group of radicals have been arrested and even threatened the lives of those employees and Mr. Weeks. It would be a terrible shame to reward such behavior. These extremists have the ultimate goal of eliminating all pet ownership. As ponies and horses are not native to North America, what would be the alternative? Euthanize all ponies and horses in North America as an invasive species? What will happen to the ponies of Mr. Weeks' operation if you shut it down? It is doubtful that they will benefit.

Please decide on the basis of reason, common sense and the facts to extend the contract with Mr. Weeks and the Griffith Park Pony Rides operation.

Thank you for your consideration.

Sincerely,

~~Eric Von Boren~~

Dear Recreation and Park Commissioners and Executive Team,

I am calling upon your resignation for allowing ongoing animal abuse at Griffith Park and Pony Rides. It is shocking that you're allowing this park to remain open when Stephen Week is in violation of the law and his current contract.

It appears you are providing a disservice to all Angelenos by allowing animal abuse to continue and that is why we are asking you all to resign if you cannot get this simple but urgent matter resolved ASAP!!!

You pass inspection reports when laws are being violated, you don't answer public act requests, and you're allowing a concessionaire to operate when he is in violation of his contract.

This is a humanitarian concern above all! These innocent ponies are suffering terribly and for NO good reason!!!

Every single one of the animals at Griffith Park need to be at a sanctuary, immediately!

Respectfully,

~~Geoffrey Connelly~~

Dear Los Angeles Recreation and Park Commissioners and Executive Team,

I am calling upon your resignation for allowing ongoing animal abuse at Griffith Park and Pony Rides. It is egregious that you're allowing for this park to remain open when Stephen Week is in violation of the law and his current contract.

Resign immediately. You're providing a disservice to all Angelenos by excusing animal abuse! You pass inspection reports when laws are being violated, you don't answer public act request, and you're allowing for a concessionaire to operate when he is in violation of his contract.

Every single one of the animals at Griffith Park need to be at a sanctuary, immediately!

Dear Los Angeles Recreation and Park Commissioners and Executive Team,

I am calling upon your resignation for allowing ongoing animal abuse at Griffith Park and Pony Rides. It is egregious that you're allowing for this park to remain open when Stephen Week is in violation of the law and his current contract.

Resign immediately. You're providing a disservice to all Angelenos by excusing animal abuse! You pass inspection reports when laws are being violated, you don't answer public act request, and you're allowing for a concessionaire to operate when he is in violation of his contract.

Every single one of the animals at Griffith Park need to be at a sanctuary, immediately!

Dear Los Angeles Recreation and Park Commissioners and Executive Team,

I am calling upon your resignation for allowing ongoing animal abuse at Griffith Park and Pony Rides. It is egregious that you're allowing for this park to remain open when Stephen Week is in violation of the law and his current contract.

Resign immediately. You're providing a disservice to all Angelenos by excusing animal abuse! You pass inspection reports when laws are being violated, you don't answer public act request, and you're allowing for a concessionaire to operate when he is in violation of his contract.

Every single one of the animals at Griffith Park need to be at a sanctuary, immediately!

Dear Los Angeles Recreation and Park Commissioners and Executive Team,

I am calling upon your resignation for allowing ongoing animal abuse at Griffith Park and Pony Rides. It is egregious that you're allowing for this park to remain open when Stephen Week is in violation of the law and his current contract.

Resign immediately. You're providing a disservice to all Angelenos by excusing animal abuse! You pass inspection reports when laws are being violated, you don't answer public act request, and you're allowing for a concessionaire to operate when he is in violation of his contract.

Every single one of the animals at Griffith Park need to be at a sanctuary, immediately!

Dear Los Angeles Recreation and Park Commissioners and Executive Team,

I am calling upon your resignation for allowing ongoing animal abuse at Griffith Park and Pony Rides. It is egregious that you're allowing for this park to remain open when Stephen Week is in violation of the law and his current contract.

Resign immediately. You're providing a disservice to all Angelenos by excusing animal abuse! You pass inspection reports when laws are being violated, you don't answer public act request, and you're allowing for a concessionaire to operate when he is in violation of his contract.

Every single one of the animals at Griffith Park need to be at a sanctuary, immediately!

Dear Los Angeles Recreation and Park Commissioners and Executive Team,

I am calling upon your resignation for allowing ongoing animal abuse at Griffith Park and Pony Rides. It is egregious that you're allowing for this park to remain open when Stephen Week is in violation of the law and his current contract.

Resign immediately. You're providing a disservice to all Angelenos by excusing animal abuse! You pass inspection reports when laws are being violated, you don't answer public act request, and you're allowing for a concessionaire to operate when he is in violation of his contract.

Every single one of the animals at Griffith Park need to be at a sanctuary, immediately!

Dear Los Angeles Recreation and Park Commissioners and Executive Team,

I am calling upon your resignation for allowing ongoing animal abuse at Griffith Park and Pony Rides. It is egregious that you're allowing for this park to remain open when Stephen Week is in violation of the law and his current contract.

Resign immediately. You're providing a disservice to all Angelenos by excusing animal abuse! You pass inspection reports when laws are being violated, you don't answer public act request, and you're allowing for a concessionaire to operate when he is in violation of his contract.

Every single one of the animals at Griffith Park need to be at a sanctuary, immediately!

Dear Los Angeles Recreation and Park Commissioners and Executive Team,

I am calling upon your resignation for allowing ongoing animal abuse at Griffith Park and Pony Rides. It is egregious that you're allowing for this park to remain open when Stephen Week is in violation of the law and his current contract.

Resign immediately. You're providing a disservice to all Angelenos by excusing animal abuse! You pass inspection reports when laws are being violated, you don't answer public act request, and you're allowing for a concessionaire to operate when he is in violation of his contract.

Every single one of the animals at Griffith Park need to be at a sanctuary, immediately!

Dear Recreation and Park Commissioners and Executive Team,

In 2022, how can anyone think that using ponies to haul around kids in the heat is humane? These equines have been stripped of the ability to do anything that comes naturally to them. Beasts of burden have no place in modern day society. Please do the right thing by shutting down this archaic, exploitive concession and sending the animals to a sanctuary.

Thank you.

Comment

Dear Los Angeles Recreation and Park Commissioners and Executive Team,
I am calling upon your resignation for allowing ongoing animal abuse at Griffith Park and Pony Rides. It is egregious that you're allowing for this park to remain open when Stephen Week is in violation of the law and his current contract.

Resign immediately. You're providing a disservice to all Angelenos by excusing animal abuse! You pass inspection reports when laws are being violated, you don't answer public act request, and you're allowing for a concessionaire to cooperate when he is in violation of his contract.
Every single one of the animals at Griffith Park need to be at a sanctuary, immediately!

Dear Los Angeles Recreation and Park Commissioners and Executive Team,
I am calling upon your resignation for allowing ongoing animal abuse at Griffith Park and Pony Rides. It is egregious that you're allowing for this park to remain open when Stephen Week is in violation of the law and his current contract.

Resign immediately. You're providing a disservice to all Angelenos by excusing animal abuse! You pass inspection reports when laws are being violated, you don't answer public act request, and you're allowing for a concessionaire to cooperate when he is in violation of his contract.
Every single one of the animals at Griffith Park need to be at a sanctuary, immediately!

Hi, I am texting to encourage you to support the ponies at Griffith Park. The horses and ponies of the world need people who love them and care for them. This ride is the starting point of many new horse enthusiasts that will care for horses and ponies all their lives. Animal activists are the people who do nothing of what they do, and will end the love and care of future horses and ponies. Please stop them. Kids need animals to learn love of all living things in many different ways. These ponies are well cared for by people who know what they are doing. Stop the crazy animal activist that know not what they are doing.

Dear Commissioners,

I am writing to ask that you grant Stephen Weeks another 1 year extension on his operating permit for the pony rides. I've been up there since the fiasco with the animal extremist groups started. I'm a registered veterinary technician, experienced with working with all breeds of horses, a horse owner until my own horses passed on, and a former employee of Disneyland's Circle D Ranch, which housed horses, ponies, draft breeds, burros, goats, as well as many other species.

The Pony Rides are kept in a manner very similar to Disneyland's Big Thunder Ranch- employees cleaning, interacting with guests, animals calm and well-behaved. The ponies are not being forced to work, in fact, several ponies would take a trip around their track even when it wasn't their turn.

The fact that Mr. Weeks has complied with all of the recommendations made, plus hired a full time Animal Welfare Officer to oversee each pony's health daily, says a lot about his commitment to provide a safe, well-run facility in which Angelenos can spend quality family time. Ponies are not treated as commodities- if they were, they would be sent to auction the second they became infirm, or ill. Ponies are treated as the valuable partner in an entertainment field. Please don't take that away from the children. This may be their only chance to interact with a horse.

Thank you,

~~Katharine Phillipson~~

Dear Los Angeles Recreation and Park Commissioners and Executive Team,
I am calling upon your resignation for allowing ongoing animal abuse at Griffith Park and Pony Rides. It is egregious that you're allowing for this park to remain open when Stephen Week is in violation of the law and his current contract.

Resign immediately. You're providing a disservice to all Angelenos by excusing animal abuse! You pass inspection reports when laws are being violated, you don't answer public act request, and you're allowing for a concessionaire to cooperate when he is in violation of his contract.
Every single one of the animals at Griffith Park need to be at a sanctuary, immediately!

Dear Los Angeles Recreation and Park Commissioners and Executive Team,
I am calling upon your resignation for allowing ongoing animal abuse at Griffith Park and Pony Rides. It is egregious that you're allowing for this park to remain open when Stephen Week is in violation of the law and his current contract.

Resign immediately. You're providing a disservice to all Angelenos by excusing animal abuse! You pass inspection reports when laws are being violated, you don't answer public act request, and you're allowing for a concessionaire to cooperate when he is in violation of his contract.
Every single one of the animals at Griffith Park need to be at a sanctuary, immediately!

Dear Los Angeles Recreation and Park Commissioners and Executive Team,
I am calling upon your resignation for allowing ongoing animal abuse at Griffith Park and Pony Rides. It is egregious that you're allowing for this park to remain open when Stephen Week is in violation of the law and his current contract.

Resign immediately. You're providing a disservice to all Angelenos by excusing animal abuse! You pass inspection reports when laws are being violated, you don't answer public act request, and you're allowing for a concessionaire to cooperate when he is in violation of his contract.
Every single one of the animals at Griffith Park need to be at a sanctuary, immediately!

Dear Los Angeles Recreation and Park Commissioners and Executive Team,
I am calling upon your resignation for allowing ongoing animal abuse at Griffith Park and Pony Rides. It is egregious that you're allowing for this park to remain open when Stephen Week is in violation of the law and his current contract.

Resign immediately. You're providing a disservice to all Angelenos by excusing animal abuse! You pass inspection reports when laws are being violated, you don't answer public act request, and you're allowing for a concessionaire to cooperate when he is in violation of his contract.
Every single one of the animals at Griffith Park need to be at a sanctuary, immediately!

Dear Los Angeles Recreation and Park Commissioners and Executive Team,
I am calling upon your resignation for allowing ongoing animal abuse at Griffith Park and Pony Rides. It is egregious that you're allowing for this park to remain open when Stephen Week is in violation of the law and his current contract.

Resign immediately. You're providing a disservice to all Angelenos by excusing animal abuse! You pass inspection reports when laws are being violated, you don't answer public act request, and you're allowing for a concessionaire to cooperate when he is in violation of his contract.
Every single one of the animals at Griffith Park need to be at a sanctuary, immediately!

Dear Los Angeles Recreation and Park Commissioners and Executive Team,
I am calling upon your resignation for allowing ongoing animal abuse at Griffith Park and Pony Rides. It is egregious that you're allowing for this park to remain open when Stephen Week is in violation of the law and his current contract.

Resign immediately. You're providing a disservice to all Angelenos by excusing animal abuse! You pass inspection reports when laws are being violated, you don't answer public act request, and you're allowing for a concessionaire to cooperate when he is in violation of his contract.
Every single one of the animals at Griffith Park need to be at a sanctuary, immediately!

Dear Los Angeles Recreation and Park Commissioners and Executive Team,
I am calling upon your resignation for allowing ongoing animal abuse at Griffith Park and Pony Rides. It is egregious that you're allowing for this park to remain open when Stephen Week is in violation of the law and his current contract.

Resign immediately. You're providing a disservice to all Angelenos by excusing animal abuse! You pass inspection reports when laws are being violated, you don't answer public act request, and you're allowing for a concessionaire to cooperate when he is in violation of his contract.
Every single one of the animals at Griffith Park need to be at a sanctuary, immediately!

Dear Los Angeles Recreation and Park Commissioners and Executive Team,
I am calling upon your resignation for allowing ongoing animal abuse at Griffith Park and Pony Rides. It is egregious that you're allowing for this park to remain open when Stephen Week is in violation of the law and his current contract.

Resign immediately. You're providing a disservice to all Angelenos by excusing animal abuse! You pass inspection reports when laws are being violated, you don't answer public act request, and you're allowing for a concessionaire to cooperate when he is in violation of his contract.
Every single one of the animals at Griffith Park need to be at a sanctuary, immediately!

Comment

Dear Los Angeles Recreation and Park Commissioners and Executive Team,
I am calling upon your resignation for allowing ongoing animal abuse at Griffith Park and Pony Rides. It is egregious that you're allowing for this park to remain open when Stephen Week is in violation of the law and his current contract.

Resign immediately. You're providing a disservice to all Angelenos by excusing animal abuse! You pass inspection reports when laws are being violated, you don't answer public act request, and you're allowing for a concessionaire to cooperate when he is in violation of his contract.

Every single one of the animals at Griffith Park need to be at a sanctuary, immediately!

Dear Los Angeles Recreation and Park Commissioners and Executive Team,

I am calling upon your resignation for allowing ongoing animal abuse at Griffith Park and Pony Rides. It is egregious that you're allowing for this park to remain open when Stephen Week is in violation of the law and his current contract.

Resign immediately. You're providing a disservice to all Angelenos by excusing animal abuse! You pass inspection reports when laws are being violated, you don't answer public act request, and you're allowing for a concessionaire to cooperate when he is in violation of his contract.

Every single one of the animals at Griffith Park need to be at a sanctuary, immediately!

Dear Los Angeles Recreation and Park Commissioners and Executive Team,

I am calling upon your resignation for allowing ongoing animal abuse at Griffith Park and Pony Rides. It is egregious that you're allowing for this park to remain open when Stephen Week is in violation of the law and his current contract.

Resign immediately. You're providing a disservice to all Angelenos by excusing animal abuse! You pass inspection reports when laws are being violated, you don't answer public act request, and you're allowing for a concessionaire to cooperate when he is in violation of his contract.

Every single one of the animals at Griffith Park need to be at a sanctuary, immediately!

Dear Los Angeles Recreation and Park Commissioners and Executive Team,

I am calling upon your resignation for allowing ongoing animal abuse at Griffith Park and Pony Rides. It is egregious that you're allowing for this park to remain open when Stephen Week is in violation of the law and his current contract.

Resign immediately. You're providing a disservice to all Angelenos by excusing animal abuse! You pass inspection reports when laws are being violated, you don't answer public act request, and you're allowing for a concessionaire to cooperate when he is in violation of his contract.

Every single one of the animals at Griffith Park need to be at a sanctuary, immediately!

Dear Los Angeles Recreation and Park Commissioners and Executive Team,

I am calling upon your resignation for allowing ongoing animal abuse at Griffith Park and Pony Rides. It is egregious that you're allowing for this park to remain open when Stephen Week is in violation of the law and his current contract.

Resign immediately. You're providing a disservice to all Angelenos by excusing animal abuse! You pass inspection reports when laws are being violated, you don't answer public act request, and you're allowing for a concessionaire to cooperate when he is in violation of his contract.

Every single one of the animals at Griffith Park need to be at a sanctuary, immediately!

Dear Los Angeles Recreation and Park Commissioners and Executive Team,

I am calling upon your resignation for allowing ongoing animal abuse at Griffith Park and Pony Rides. It is egregious that you're allowing for this park to remain open when Stephen Week is in violation of the law and his current contract.

Resign immediately. You're providing a disservice to all Angelenos by excusing animal abuse! You pass inspection reports when laws are being violated, you don't answer public act request, and you're allowing for a concessionaire to cooperate when he is in violation of his contract.

Every single one of the animals at Griffith Park need to be at a sanctuary, immediately!

Dear Los Angeles Recreation and Park Commissioners and Executive Team,

I am calling upon your resignation for allowing ongoing animal abuse at Griffith Park and Pony Rides. It is egregious that you're allowing for this park to remain open when Stephen Week is in violation of the law and his current contract.

Resign immediately. You're providing a disservice to all Angelenos by excusing animal abuse! You pass inspection reports when laws are being violated, you don't answer public act request, and you're allowing for a concessionaire to cooperate when he is in violation of his contract.

Every single one of the animals at Griffith Park need to be at a sanctuary, immediately!

Dear Los Angeles Recreation and Park Commissioners and Executive Team,

I have cared for elderly horses and ponies for over a decade, horses that have been given a kind retirement when too old to carry riders. I am deeply saddened by what I see going on at Griffith Park. A rider much too large for a small pony sitting on her cell phone while the pony labored under the excess weight. Horses' backs and joints are not meant to carry excessively heavy loads, and I often see these ponies walking with obvious lameness in their gates. Any time you use animals like this for profit, it is always the animals who pay. Making these ponies labor in the heat as I have seen is cruel and only teaches children that it's OK to abuse animals for their pleasure.

How can you allow this operation to remain open when Stephen Week is in violation of the law and his current contract?

I am calling upon your resignation for allowing ongoing animal abuse at Griffith Park and Pony Rides.

You are providing a disservice to all Angelenos, and to these poor ponies, by excusing animal abuse! You pass inspection reports when laws are being violated, you don't answer public act requests, and you're allowing for a concessionaire to operate when he is in violation of his contract.

The animals at Griffith Park should be retired to a suitable sanctuary immediately.

~~Dear Los Angeles Recreation and Park Commissioners and Executive Team,~~

Dear Los Angeles Recreation and Park Commissioners and Executive Team,

I am calling upon your resignation for allowing ongoing animal abuse at Griffith Park and Pony Rides. It is egregious that you're allowing for this park to remain open when Stephen Week is in violation of the law and his current contract.

Resign immediately. You're providing a disservice to all Angelenos by excusing animal abuse! You pass inspection reports when laws are being violated, you don't answer public act request, and you're allowing for a concessionaire to cooperate when he is in violation of his contract.

Every single one of the animals at Griffith Park need to be at a sanctuary, immediately!

Dear Los Angeles Recreation and Park Commissioners and Executive Team,

I am calling upon your resignation for allowing ongoing animal abuse at Griffith Park and Pony Rides. It is egregious that you're allowing for this park to remain open when Stephen Week is in violation of the law and his current contract.

Resign immediately. You're providing a disservice to all Angelenos by excusing animal abuse! You pass inspection reports when laws are being violated, you don't answer public act request, and you're allowing for a concessionaire to cooperate when he is in violation of his contract.

Every single one of the animals at Griffith Park need to be at a sanctuary, immediately!

Dear Los Angeles Recreation and Park Commissioners and Executive Team,

I am calling upon your resignation for allowing ongoing animal abuse at Griffith Park and Pony Rides. It is egregious that you're allowing for this park to remain open when Stephen Week is in violation of the law and his current contract.

Resign immediately. You're providing a disservice to all Angelenos by excusing animal abuse! You pass inspection reports when laws are being violated, you don't answer public act request, and you're allowing for a concessionaire to cooperate when he is in violation of his contract.

Every single one of the animals at Griffith Park need to be at a sanctuary, immediately!

Dear Los Angeles Recreation and Park Commissioners and Executive Team,

I am calling upon your resignation for allowing ongoing animal abuse at Griffith Park and Pony Rides. It is egregious that you're allowing for this park to remain open when Stephen Week is in violation of the law and his current contract.

Resign immediately. You're providing a disservice to all Angelenos by excusing animal abuse! You pass inspection reports when laws are being violated, you don't answer public act request, and you're allowing for a concessionaire to cooperate when he is in violation of his contract.

Every single one of the animals at Griffith Park need to be at a sanctuary, immediately!

Comment

Dear Los Angeles Recreation and Park Commissioners and Executive Team,
I am calling upon your resignation for allowing ongoing animal abuse at Griffith Park and Pony Rides. It is egregious that you're allowing for this park to remain open when Stephen Week is in violation of the law and his current contract.

Resign immediately. You're providing a disservice to all Angelenos by excusing animal abuse! You pass inspection reports when laws are being violated, you don't answer public act request, and you're allowing for a concessionaire to cooperate when he is in violation of his contract.

Every single one of the animals at Griffith Park need to be at a sanctuary, immediately!

Dear Los Angeles Recreation and Park Commissioners and Executive Team,

I am calling upon your resignation for allowing ongoing animal abuse at Griffith Park and Pony Rides. It is egregious that you're allowing for this park to remain open when Stephen Week is in violation of the law and his current contract.

Resign immediately. You're providing a disservice to all Angelenos by excusing animal abuse! You pass inspection reports when laws are being violated, you don't answer public act request, and you're allowing for a concessionaire to cooperate when he is in violation of his contract.

Every single one of the animals at Griffith Park need to be at a sanctuary, immediately!

Dear Los Angeles Recreation and Park Commissioners and Executive Team,

I am calling upon your resignation for allowing ongoing animal abuse at Griffith Park and Pony Rides. It is egregious that you're allowing for this park to remain open when Stephen Week is in violation of the law and his current contract.

Resign immediately. You're providing a disservice to all Angelenos by excusing animal abuse! You pass inspection reports when laws are being violated, you don't answer public act request, and you're allowing for a concessionaire to cooperate when he is in violation of his contract.

Every single one of the animals at Griffith Park need to be at a sanctuary, immediately!

Dear Los Angeles Recreation and Park Commissioners and Executive Team,

I am calling upon your resignation for allowing ongoing animal abuse at Griffith Park and Pony Rides. It is egregious that you're allowing for this park to remain open when Stephen Week is in violation of the law and his current contract.

Resign immediately. You're providing a disservice to all Angelenos by excusing animal abuse! You pass inspection reports when laws are being violated, you don't answer public act request, and you're allowing for a concessionaire to cooperate when he is in violation of his contract.

Every single one of the animals at Griffith Park need to be at a sanctuary, immediately!

Dear Los Angeles Recreation and Park Commissioners and Executive Team,

I am calling upon your resignation for allowing ongoing animal abuse at Griffith Park and Pony Rides. It is egregious that you're allowing for this park to remain open when Stephen Week is in violation of the law and his current contract.

Resign immediately. You're providing a disservice to all Angelenos by excusing animal abuse! You pass inspection reports when laws are being violated, you don't answer public act request, and you're allowing for a concessionaire to cooperate when he is in violation of his contract.

Every single one of the animals at Griffith Park need to be at a sanctuary, immediately!

Dear Los Angeles Recreation and Park Commissioners and Executive Team,

I am calling upon your resignation for allowing ongoing animal abuse at Griffith Park and Pony Rides. It is egregious that you're allowing for this park to remain open when Stephen Week is in violation of the law and his current contract.

Resign immediately. You're providing a disservice to all Angelenos by excusing animal abuse! You pass inspection reports when laws are being violated, you don't answer public act request, and you're allowing for a concessionaire to cooperate when he is in violation of his contract.

Every single one of the animals at Griffith Park need to be at a sanctuary, immediately!

Dear Los Angeles Recreation and Park Commissioners and Executive Team,

I am calling upon your resignation for allowing ongoing animal abuse at Griffith Park and Pony Rides. It is egregious that you're allowing for this park to remain open when Stephen Week is in violation of the law and his current contract.

Resign immediately. You're providing a disservice to all Angelenos by excusing animal abuse! You pass inspection reports when laws are being violated, you don't answer public act request, and you're allowing for a concessionaire to cooperate when he is in violation of his contract.

Every single one of the animals at Griffith Park need to be at a sanctuary, immediately!

Dear Recreation and Park Commissioners Recreation and Park Commissioners,

As a Los Angeles resident who cares about the wellbeing of animals and an In Defense of Animals supporter, I urge you to stop animal suffering in your district by eliminating the Griffith Park Pony Rides and Petting Zoo's contract, replacing Griffith Park with a non-animal model and sending all of the animals to a sanctuary.

For five years, your agency has passed inspection reports for the concession, while the owner Stephen Weeks has been breaking California Health and Safety Code 25998. Elderly ponies and horses at Griffith Park Pony Rides have documented depression. Spot the pony has lameness, yet is forced to carry people on his back. Recently an overweight sheep was in distress with no worker attending to her needs, and many horses and ponies were itching due to their halters, which appear to be on all the time. Elderly ponies and horses were also seen being hit and chased for almost eight and half hours on the weekend.

No amount of improvement will ensure that these animals are not suffering from depression. Independent equine expert Rachael Sacher DVM, CVA reported elderly ponies working with saddle sores, elderly ponies with no dental treatment, no identification methods for any of the animals, and an elderly pony with a fever undetected by this concession while your department and Stephen Weeks make millions off the backs of these elderly ponies. Griffith Park Pony Rides pays Recreation and Parks a revenue-sharing fee of 25 percent of their gross income, and as a Los Angeles constituent, I oppose city funds generated from animal abuse.

Pony rides exploit animals for amusement and profit. This practice teaches children the wrong lessons about animals as objects for amusement instead of appreciating our animal neighbors as sentient beings.

This concession also poses a risk to children. Last year, a child was reportedly dragged by a pony after her saddle slipped, and the pony continued dragging her body because the pony was spooked.

I respectfully request that the pony ride contract be canceled rather than renewed. Please undertake a study to consider alternative proposals that are generated from a non-animal model for the site that would engage children and families. Lastly, I urge you to send all of the animals to a sanctuary, which advocates have already arranged and confirmed.

Thank you for considering the well-being of animals in our community. Please make compassionate choices to improve the quality of life for our animal neighbors.

Dear Recreation and Park Commissioners Recreation and Park Commissioners,

As a Los Angeles resident who cares about the wellbeing of animals and an In Defense of Animals supporter, I urge you to stop animal suffering in your district by eliminating the Griffith Park Pony Rides and Petting Zoo's contract, replacing Griffith Park with a non-animal model and sending all of the animals to a sanctuary.

For five years, your agency has passed inspection reports for the concession, while the owner Stephen Weeks has been breaking California Health and Safety Code 25998. Elderly ponies and horses at Griffith Park Pony Rides have documented depression. Spot the pony has lameness, yet is forced to carry people on his back. Recently an overweight sheep was in distress with no worker attending to her needs, and many horses and ponies were itching due to their halters, which appear to be on all the time. Elderly ponies and horses were also seen being hit and chased for almost eight and half hours on the weekend.

No amount of improvement will ensure that these animals are not suffering from depression. Independent equine expert Rachael Sacher DVM, CVA reported elderly ponies working with saddle sores, elderly ponies with no dental treatment, no identification methods for any of the animals, and an elderly pony with a fever undetected by this concession while your department and Stephen Weeks make millions off the backs of these elderly ponies. Griffith Park Pony Rides pays Recreation and Parks a revenue-sharing fee of 25 percent of their gross income, and as a Los Angeles constituent, I oppose city funds generated from animal abuse.

Pony rides exploit animals for amusement and profit. This practice teaches children the wrong lessons about animals as objects for amusement instead of appreciating our animal neighbors as sentient beings.

This concession also poses a risk to children. Last year, a child was reportedly dragged by a pony after her saddle slipped, and the pony continued dragging her body because the pony was spooked.

I respectfully request that the pony ride contract be canceled rather than renewed. Please undertake a study to consider alternative proposals that are generated from a non-animal model for the site that would engage children and families. Lastly, I urge you to send all of the animals to a sanctuary, which advocates have already arranged and confirmed.

Thank you for considering the well-being of animals in our community. Please make compassionate choices to improve the quality of life for our animal neighbors.

Comment

Dear Commissioners and Michael Shull, Last weekend horses and ponies were hit and overworked for 8 ½ hours. Sheep in the petting was in distress with no worker attending to her needs, and many horses and ponies halters were itching.

<https://youtu.be/Ob0pD58k4E0>
<https://youtu.be/DGcWj9Gik3Y>

As a LA constituent, I do not want city funds generated from animal abuse. Pony rides regardless of who is operating them, are no longer acceptable in these modern times when we reject the exploitation of animals for amusement and profit. The institution, itself, the pony rides are problematic because they inevitably teach children the wrong lessons about animals, that they are not sentient beings but objects for amusement. I am requesting from you that the pony ride contract not be renewed, and that a study be undertaken to consider alternative proposals for the site that would engage children and families, that are generated from a non-animal model. Thank you

Good morning,
Please consider our letter regarding the pony rides concession in Griffith Park, attached.
Best regards,

Hello,

I have written to you already voicing my anger at the egregious manner by which the Griffith Park Pony Rides were shut down. You are now soliciting ideas for "reimagining" the venue. I think you need look no further than the recommendations of Dr Rachael Sachar DVM, CVA, the veterinarian hired by the city. In the conclusion her final report she stated

"I suggest there be additional discussions, provisions, and modifications to expand the concession's potential use beyond its current value as a recreational activity and/or place of entertainment. It would be of greater value to the community for the concession to incorporate educational opportunities to the public and collaborate with existing community programs to ensure that it continues to be a viable and sustainable concession and feature for Los Angeles and surrounding communities as well as an important attraction and recreational activity for its residents." This sentiment was echoed by Dr Ramey DVM and President of the Los Angeles Equine Advisory Board who wrote in strong support of keeping a pony ride concession in Griffith Park.

Dr Sachar in her first report says that she was asked to research policies for working animals in other cities which she said was beyond the scope of her initial contract with RAP. She also noted that she has worked with sanctuaries and animals in film and TV that are under intense scrutiny by the most extreme animal rights advocates. They voluntarily follow more intense guidelines. She recommends that Griffith Park Pony Rides do the same. To me this is the win/win answer. The current, mostly older ponies have all gone to good homes, the more reasonable protesters can claim a victory. The most extreme protesters who hold that riding a horse, in and of itself, is a form of abuse, as well as those who continue to attack Mr Weeks personally should have no place in this discussion. We should start again with new ponies and far stricter guidelines and regulations, as well as educational components. No one supports animal abuse, but the vast majority of people do not believe that riding a horse is abusive. If we allow the pony rides to be shut down we embolden Ms Fahim and LAAA to go after other horse related venues. What's next, trail rides, and Griffith Park Mounted Rangers? The LA mounted police horses? What about the Rose Parade? And how do we justify holding the Olympics in Los Angeles if we are not an equestrian friendly city?

Lastly there is Sec. 595 b) Lease of Facilities from the Los Angeles Charter Recreation and Parks Department. I'm not a lawyer, but if this is still current and means what I think it means, then the venue can only be leased as a pony ride.

Thank you so much for taking the time to read this,

Sec. 595. Lease of Facilities.

The Board of Recreation and Park Commissioners may lease for recreational purposes any municipal auditoriums, arenas, sports centers or related facilities subject to the following conditions:

The Bronson item I would like to suggest a DG path instead of concrete sidewalk. Aesthetics, and less infringing on next-to sycamores.

Please reinstate pony rides !! They are beloved and a historical treasure.

To whom it may concern,

I saw Zora screaming at the birthday parties one day so I stopped and I told her she was scaring the children a few were crying.

This was after the vet check passed so I didn't understand why she was still out there screaming her lies.

The vet check debunked her false animal abuse accusations yet she continues to smear his name.

And Then somehow she won?

She screamed at me that I was an animal abuser and owning horses was slavery. She said I was a slave owner.

I tried to explain to her that she should be down at the auction where they sell the overpopulated horses to kill factories.

I asked her if she knew about the mustangs problem?

I asked her where will the horses go?

Sanctuary's s? I asked her if she knew how much it cost to keep a horse... who's going to pay...

A person on a horse's back a kid on a pony's back is like a person carrying a backpack.

They think when a pony's head is down it's sad but that's how they relax or rest...or look for food

A simple Google search can tell you this.

Quote. A dropped head is a sign your horse is relaxed and feeling good.

If he's standing in his stall or pasture with a lowered head, he's probably either resting, relaxing or asleep.

They have no knowledge.

They have no facts.

They have no solutions.

Griffith Park Pony Rides have been there for 73 years. Packed every weekend with happy little kids.

I've met two and three generations there. Family traditions.

When the ponies retire they get to stay with their herd and receive love and care until they pass.

They have rehomed numerous ponies into our community and I'm sure have been used by the studios over the years.

Her complaints had been addressed and resolved.

A vet came out and inspected and passed. So what changed?

What facts have been presented?

What were the new legitimate complaints?

I think we deserve to know. I haven't heard a valid reason yet so my suspicion is they were sick of her coming to their offices screaming so they caved to an obnoxious extremist activist who is uninformed and has zero evidence of anything that supports this action.

Who is fighting for the Equestrian community because I keep reaching out to my local representatives and get crickets and we're losing ground every day.

Activists don't understand and obviously the politicians don't understand that many horses/ponies without jobs or a purpose are often sold for meat or glue or euthanized.

I would like an answer on how this happened. This was wrong.

Comment

I am Steve Scauzillo, staff writer, with Southern California News Group. I've covered the closing of the Griffith Park Pony Rides during these past few weeks. I will put my questions below. I would certainly like to hear back from you or your designated spokesperson regarding any future plans, ideas, concepts for the now closed Pony Rides location within the Park.

1. Can you tell me about what I've learned are some historic structures there? I believe it is the ticket kiosk and the customer waiting area, as well as the pony path and fencing. Weren't these original (circa 1946 or 1947?)
 2. Can you tell me more about these structures?
 3. Would any new use, development, concession have to keep these structures? Or can they be taken down?
 4. Can you or your spokesperson tell me what ideas, concepts are being planned or thought of for this area no longer in use? What do you personally think might be a good use there in the future? If none, can you tell me about that and perhaps explain.
 5. Is there an upcoming RAP meeting agenda that has future of this area of Griffith Park as a discussion or action item? Please, if you will be so kind, to let me know.
- I have a deadline for my story on Wednesday, Jan. 4, at 2 p.m.

Sincerely, Steve Scauzillo, Southern California News Group, The Daily News Group

Dear Los Angeles Recreation and Parks Los Angeles Recreation and Parks,

As someone who cares about the well-being of animals and one of over 250,000 In Defense of Animals supporters, I thank you for not renewing the Griffith Park Pony Rides and Petting Zoo contract and ending the prolonged suffering of the ponies and farmed animals at the facility. Not only do pony rides involve animal suffering, but they also teach children that it's acceptable to use animals for entertainment instead of teaching them to respect and appreciate animals as sentient beings.

I urge you to replace the current concession with a non-animal model. There are many options to consider that do not involve exploiting animals, including environmental education programs, where families can learn how to respect and care for native plants and animals within the park. Creating an opportunity for children to learn about respecting nature and wild animals at the iconic Griffith Park would provide an enriching and positive experience. Ideas that involve entertainment include go-karts, inflatable obstacle courses, or a FUNBOX (an inflatable bounce park). Now is the perfect time to switch all city parks to non-animal entertainment models. Thank you for your consideration, and for continuing Los Angeles' legacy as leaders of humane animal welfare policies.

Sincerely, Ms. Anita Caspell

The Board of Commissioners must step up to the plate and help to stop these fanatics. More arrests? More of a presence? Something must be done before something bad happens. These are fanatics that will not control themselves. It's up to you to stop this insanity.

To Whom It May Concern:

I am writing in support of the Griffith Park Pony Rides as an area resident, equestrian and animal lover. While extreme opinions about animal welfare and wellbeing will always exist, I feel strongly that some basic education about horses and ponies should be made available to all concerned.

Far from wanting to protect some elitist "equestrian lifestyle", I know how rare and how meaningful the opportunities for children's early encounters with horses can be. Besides being an essential part of the history of mankind, horses are an important part of our local history, and the history of film and television. Unfortunately with no first-hand knowledge of horses, many people form their impressions based on film, tv and literary caricatures - any horse in a harness is suffering a la Black Beauty, happy horses run and neigh constantly like The Black Stallion.

I would propose distributing something like the following.

Atwater Village

Horses and Ponies

Horses and Ponies like knowing everything is alright. As prey animals, their primary concerns are food and safety. They like the comfort of a herd or group, and like having leaders to protect them and alert them to any danger. Because of these traits, they become our willing partners.

Horses and Ponies often rest and relax with their heads low and their necks long. It does not mean they are unhappy or exhausted.

Horses and Ponies will often choose to stand in the rain, sun, wind or cold rather than use a shelter provided to them. Unlike us, they are designed to tolerate some variations in weather.

Older Horses and Ponies who are not in regular athletic work may look slightly bony. Like us, they show their age. Also like us, they are subject to metabolic issues and crippling diseases when overweight. Walking and carrying a tiny child is not athletic work for an equine.

Horses and Ponies do not like sudden movements, waving signs, yelling or other disruptions to their regular routine. They do not like people around them to be upset or angry. **THEY DO NOT LIKE BEING AROUND ANGRY PEOPLE.** As herd animals, they are sensitive to any changes in their environment.

For many children and families, pony rides are a first accessible experience with these beautiful and generous animals - helping instill a lifelong love and respect for all of our animal companions.

Signs of Abuse or Neglect -

Long, curled, overgrown hooves that are painful to walk on.

Not getting regular food and water.

Hello,

I want to voice my support for the on-going operation of the Griffith Park Pony Rides. I went to the rides as a child in the early 1950's. I even ended up buying one of their ponies in the mid 1950's. I know many children do not have the opportunity to have a pony or horse of their own. This ride gives the children a chance at riding a pony. Where else could they do that in Los Angeles? The attacks that the rides have suffered in the last months are terrible. I know some things have been done, but more needs to be done to protect one of the few joyful experiences left for the children. The violence expressed by these "activists" is truly frightening. I am attaching a picture of myself on my pony, Copper, that I had in the 1950's. He was a Welsh pony and was too big and too active for the rides. I had years of fun riding and caring for him!

John Reingier

Dear RAP Commissioners:

The outrageous lies and acts of violence against the Griffith Park Pony Rides by extremist animal rights groups must stop.

There must be some action that can be taken to keep them away from the pony rides where they harass and threaten employees and members of the public who are simply trying to enjoy some peace and pleasure the way we all have done for many decades.

There is no place for violent protests by people who simply do not have any knowledge of horses or the situation that they are protesting against.

Perhaps it is necessary to station security personnel at the rides and allow only legitimate customers to enter the area.

If these people are allowed to continue to harass employees and customers, at some point, there will be an ugly incident.

Thank you for your consideration of this matter.

John Reingier

horse rider, horse owner for many decades and a local resident of the Glendale Rancho

Comment

Dear Recreation and Park Commissioners Recreation and Park Commissioners,

As a Los Angeles resident who cares about the wellbeing of animals and an In Defense of Animals supporter, I urge you to stop animal suffering in your district by eliminating the Griffith Park Pony Rides and Petting Zoo's contract, replacing Griffith Park with a non-animal model and sending all of the animals to a sanctuary. For five years, your agency has passed inspection reports for the concession, while the owner Stephen Weeks has been breaking California Health and Safety Code 25998. Elderly ponies and horses at Griffith Park Pony Rides have documented depression. Spot the pony has lameness, yet is forced to carry people on his back. Recently an overweight sheep was in distress with no worker attending to her needs, and many horses and ponies were itching due to their halters, which appear to be on all the time. Elderly ponies and horses were also seen being hit and chased for almost eight and half hours on the weekend. No amount of improvement will ensure that these animals are not suffering from depression. Independent equine expert Rachael Sacher DVM, CVA reported elderly ponies working with saddle sores, elderly ponies with no dental treatment, no identification methods for any of the animals, and an elderly pony with a fever undetected by this concession while your department and Stephen Weeks make millions off the backs of these elderly ponies. Griffith Park Pony Rides pays Recreation and Parks a revenue-sharing fee of 25 percent of their gross income, and as a Los Angeles constituent, I oppose city funds generated from animal abuse. Pony rides exploit animals for amusement and profit. This practice teaches children the wrong lessons about animals as objects for amusement instead of appreciating our animal neighbors as sentient beings.

This concession also poses a risk to children. Last year, a child was reportedly dragged by a pony after her saddle slipped, and the pony continued dragging her body because the pony was spooked.

I respectfully request that the pony ride contract be canceled rather than renewed. Please undertake a study to consider alternative proposals that are generated from a non-animal model for the site that would engage children and families. Lastly, I urge you to send all of the animals to a sanctuary, which advocates have already arranged and confirmed.

Thank you for considering the well-being of animals in our community. Please make compassionate choices to improve the quality of life for our animal neighbors.

To Whom This Concerns,

I am writing the City of Los Angeles and the Department of Recreation and Parks to suggest a way to compromise and keep the ponies and the petting zoo at Griffith Park. As with all compromises, not everyone will be happy but I'm hoping that something like this could work:

The Pony Rides could be mandated by an oversight committee. This committee could be a group of licensed or otherwise certified professionals to assure that the science in decision-making is adhered to. The facility could be inspected on demand and/or at least four times per year. Any corrections could be made in a reasonable amount of time set by these professionals.

1. Licensed Equine Veterinarians – at least two.
2. Animal Services for the humane treatment of all animals – Los Angeles certificated personnel.
3. Stable management professional – minimum 10 years documented experience with stables preferably with ponies. Responsible for the physical structure inspections and waste management.
4. A pony training and management professional – minimum ten years documented experience.
5. Historical Cultural impact – Griffith Park Heritage Committee.
6. Environmental Health Inspections – County of Los Angeles.

Additionally, I would have someone to evaluate the positive community impact of returning the ponies and petting zoo animals to the facility. The activity was a favorite of lower to middle income families that would have difficulty paying for riding lessons available to the higher income.

The age limit for the ponies and mini horses should be older than six years (for full physical development) and a mandatory retirement age of twenty-five years or sooner depending on the veterinarian input. At retirement the pony would be rehomed to a safe-vetted stable to live out its life. Any and all health concerns of the animals would be reported along with the quarterly inspections.

The average life expectancy of a horse is 25-30+ years; the average life expectancy of a pony is usually 10 years longer. Also notable is that it is more common to see ponies ridden later in life than their full-sized counterparts. There are theories that ponies are hardier/healthier than horses, contributing to both a longer lifespan and a longer under-saddle career. While genetics and a little luck play a factor in determining a pony's lifespan, there are many things within the owners' control to promote a long, healthy life. This is in the form of regular vet-checks, especially the teeth, digestive system and hooves. The addition of these inspections would make the ponies and other animals under such scrutiny that may seem overdone but would move toward satisfying the allegations of misuse and cruelty (which were never founded).

There is no substitute for firsthand pony experiences for the children of Los Angeles especially in the urban areas. Everyone I've spoken to has had a very positive experience in participation of the Griffith Park Pony Rides. Many children respond to the more kinesthetic interactions with animals. They also learn that these animals are sensitive creatures and respond to calmness and kindness. When this is learned at an early age, it can carry through to adulthood. Domestic animals help children develop their own sense of humanity and responsibility. In this controlled environment, the children and the ponies and the petting zoo animals all benefit from the experience. Domestic ponies have been bred since the middle-ages for riding and cart pulling. Carrying a tiny human is a part of their forte.

In conclusion, I'm urging all Los Angeles city government decision makers involved in this situation to use these and other ideas to bring back the Griffith Park Pony Rides. The oversight of seasoned, licensed professionals - those in the profession of the Animal Sciences can help assure full accountability of the activities with more fact and less speculative opinion.

I am a citizen of the City of Los Angeles I would hope that the City of Los Angeles Department of Recreation and Parks would please reconsider the reinstatement of the pony rides. Thank you for your time and consideration.

Sincerely,

~~Charmaine Robinson~~

Comment

Hello,

I took part in your meeting last night. I am not a horse owner, I have lived in Los Feliz for about 24 years. If you are in need of someone from the surrounding community on the ad hoc pony ride group I am interested.

When my daughter was little we used to take her to the pony rides, the train, Travel Town and Shanes Inspiration a lot. She is now about to graduate from college. I first learned that the Pony Rides were being shut down from a FB post looking for homes for the ponies. I think my first assumption was that something horrible must have happened in the years since we had been there for it to be shut down for animal abuse. Shortly thereafter an acquaintance who is a horse owner told me that she had gone down there with someone from the equestrian center expecting to see horrible abuse and instead found, and I'm paraphrasing, 'fat, healthy ponies with good teeth and hooves'. So I went back myself on a weekday to check it out. My first impression was that it was just as I remembered it, except that it was set up even better for kids birthday parties. It was like a trip down memory lane, toddler birthday parties, happy kids, happy families. As before the pony rides were a great equalizer, a venue used by folks from walks of life. I talked to the girl selling tickets who pointed me to another woman who worked with the ponies. She showed me video of one of the protesters screaming obscenities at a man holding his young child in his arms. She also told me about the Burbank Glendale Griffith Park FB Group. I am one of those people who joined to support the pony rides.

I am also a member of Al Gores Climate Reality Project (more on that later). I had reason to call my Council Member Nithya Raman's office to ask her position on the Wildlife Ordinance which some of us were following, I also asked her position on the pony rides. Her office wrote back and sent me the Vet report from Dr Sachar which Council Member Raman had requested, and told me that Mr Weeks had decided not to renew. I have since learned that Ms Raman had already written the Council Motion to not renew the lease two months earlier, and that it was not Mr Weeks who ended the lease. Let's just say that my respect for Council Member Raman, who I had voted for, diminished. I could share more, everything about the way that this was handled was disturbing. Full disclosure I was at the pony rides the last two weekends before they were shut down as part of the Save the Pony Rides contingent. It was quite the experience and I don't feel the the media coverage was very good. Be that as it may, I believe we now have to move forward. If you would like my perspective I'm here and would love to help.

As to the question of continuing meetings on zoom. I joined a Climate Reality Legislative Group during the pandemic. On several occasions we would take part via zoom in legislative committee meetings. The process is very simple, you give your name, group association if you have one, and position, that's it. The meetings were hybrid, the State Senators and Representatives were there, but people could call in as well as show up in person. We of course appreciated this option because the meetings are obviously held in Sacramento, and short of flying up or hiring a lobbyist this, and writing letters, was our only option. It's not exactly the same thing but that's my two cents.

Thank you all for the work that you do. I am incredibly happy to know that you are all here for us and for Griffith Park. I am especially pleased to hear that Griffith Park has an urban ecologist. That is excellent news.

Thank you again,

~~Sharon Gorman~~

I can't make it to the meeting tomorrow, but want to email my support for bring back the pony rides as detailed in the new proposal.

I hope to make the next meeting.

Thank you!

~~Emily Strauss~~

Hello

My idea is to bring back pony rides and perhaps add more animals for kids to visit with. Add information about how the ponies are cared for and make it educational so that there is no doubt that they are very well cared for and kept healthy and be transparent. Also add the history of the pony rides and how it came to be. How Griffith donated the land and how they've been a part of many LA childhoods for 75 years.

I've loved the piny rides for the last 60 years. Keep the tradition and improve it.

Thanks

~~Valerie Timmer~~

So, I showed up at the Visitors Center tonight because I thought there was going to be a GRIFFITH PARK ADVISORY BOARD Ad Hoc meeting about the Pony Ride venue. But nobody was there. That was frustrating.

So, I guess I'll give my opinion in this email:

The Pony Rides should be brought back. They were a wonderful way to connect children to animals in a safe setting. And they were a great tradition for over half a century.

As a lifelong animal advocate, I feel strongly that the protestors who shut this venue down were completely wrong, and ignorant of the Ponies' welfare. Their misguided agenda was out of touch with reality. And I'm disappointed that the city and park department bent to their false accusations.

I have several friends who are avid horse people and animal advocates, and they all believed the Ponies were NOT mistreated. Those are equestrian experts who think that! And yet mis-guided protestors who think a 40-pound child is a burden to a 500-POUND animal were able to shut down the venue?! Ridiculous.

Can you advise me whom else I can contact about this issue?

Please restore these rides:

People who live in public housing cannot own animals as pets. This is harmful to children in developing compassion for animals and others.

The public availability of animal rides provides and husbandry is crucial.

Many options such as sponsorship, a go-fund-me page, animal naming honoring heroes or the deceased as we do on freeways, volunteering (with vetting) can improve availability.

Comment

Dear L.A. Parks and Rec,

I want to thank you, from the bottom of my heart, for choosing NOT to renew the contract for pony rides in Griffith Park, and instead choosing a non-animal form of recreation, such as obstacle courses, that can also provide exercise to children + more jobs for adults in Los Angeles.

I'm born and raised in Los Angeles. I've been ethically against the Griffith Park pony rides for my entire life. My son, who is 7-years-old, feels the same way. When he passes these rides, his heart aches for the animals, as even he can see that they're in pain.

I hope that you can find it in your hearts to empathize. These ponies are being exploited for human entertainment. This animal abuse does not align with 2023 Los Angeles culture. Let's move forward, not backward.

Thanks so much for taking the time to read this note.

Sincerely,

~~XXXXXXXXXX~~

Hi—

I'm a thirty year Los Feliz resident, and some of our fondest memories were of our kids at the pony rides. The animals were well cared for and not abused in any way. This sudden decision to close the rides, while perhaps well-intentioned, is frankly unwarranted and deprives the community of a beloved recreation.

Best,

~~XXXXXXXXXX~~

~~XXXXXXXXXX~~

Appendix B.

Public Comments Summary Report

December 19, 2023





Reimagining the Griffith Park Pony Rides Site

Summary of Public Comments Received between December 2022 and August 2023

Background

Over the past 75 years, the Park Pony Rides had been a highly used activity in Griffith Park. The City of Los Angeles Department of Recreation and Parks (RAP) held a concessions agreement that oversaw the operations with a private business whose contract expired in December, 2022. After careful consideration RAP decided not to extend the concessions agreement to operate the Pony Rides and requested feedback from the public regarding the future use of the site.

At the time of the closure, RAP established a Feedback Form to gather ideas, input, and comments from the public regarding the future of the Pony Rides Site while the Department initiated a more comprehensive public engagement effort with the broader public (which is currently under way). As of August 2023, RAP has received and reviewed over 1,000 comments, emails, and letters from members of the public regarding the future of the Pony Rides site through the online public Feedback Form.

The Feedback Form was closed on August 31, 2023. Nine hundred forty (940) comments were received, and 83 additional letters and emails sent directly to RAP staff. Together, these public comments provide over 1,000 points of public input immediately following the closure of the pony rides that have served as a starting point for discussions on the reimagining of the site.

In addition, a list of 11,588 names in support of a non-animal model was presented to the RAP Board of Commissioners at a meeting held on November 2nd, 2023. This list will be provided to decision makers as part of the compilation of public comments and input received over the duration of the outreach process.

This summary document provides a high-level overview of the key themes and ideas shared in the public comments and is intended to be a companion document to the full set of public comments (with names and emails redacted for privacy) that can be found in in a separate companion document for a complete public record of initial feedback.

Overview of Comments Received

In general, the responses received mentioned one of five general topics:

- Support for a Pony Ride use
- Support for another use
- Mention of site's historic and/or cultural value
- Mention of need for affordability/accessibility
- Mention of need education

In addition, comments were identified with a responder's affiliation if identified (i.e. equestrian community or another formal organization or group). Figure 1 shows the number of comments either supporting or opposed to the return of a pony riding activity of some kind. The split is close to equal, with 419 commenters against pony riding of any kind, and 432 commenters in support of the return of a pony ride concession. 22 commenters did not have a clear opinion either for or against pony riding.

Figure 2 shows the three additional "big ideas" most frequently appearing in the comments received, by order of frequency. Historic and/or cultural heritage was the most frequently mentioned topic, appearing



Reimagining the Griffith Park Pony Rides Site

Summary of Public Comments Received between December 2022 and August 2023

in 136 comments (15.5 percent of all comments). Affordability and/or accessibility was the second most frequently mentioned topic, appearing in 124 comments (14.2 percent). Education (85 comments, 9.7 percent) followed.

Figure 1. Position on the Pony Rides

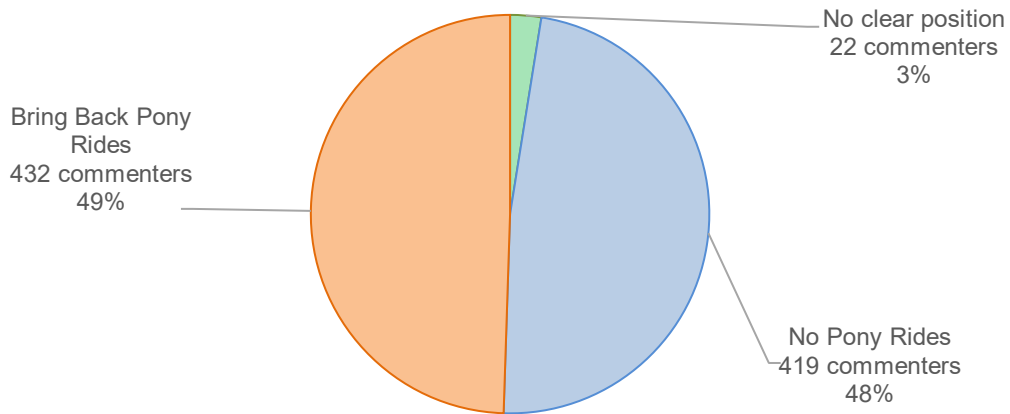
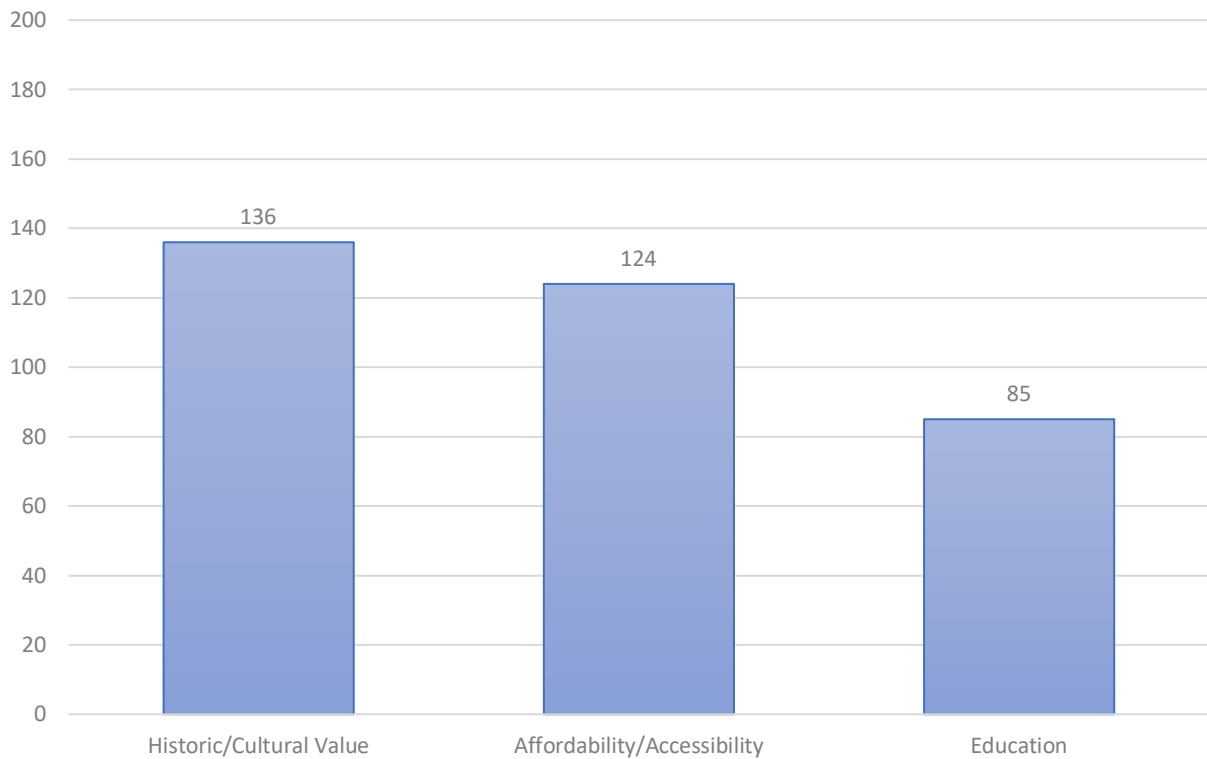

Figure 2. Number of Comments Related to Each General Topic





Reimagining the Griffith Park Pony Rides Site

Summary of Public Comments Received between December 2022 and August 2023

General Community Sentiment

SUPPORT FOR A PONY RIDE USE

Comments shared a range of reasons for their support of a pony ride concession. Commenters frequently cited their perception of the ride's positive impact on children and families. Thirty-one percent also mention historic/cultural values, 26 percent also mention affordability and accessibility, 12 percent also mention the commenter's affiliation with the equestrian community, and 8 percent mention the educational benefits of human interaction with animals. Many comments express a desire to restore the pony rides exactly as they were, or do not mention the previous concession, but focus on ponies and perceived benefits of pony riding more generally. Several comments recommend improvements to a potential new pony ride concession.

SUPPORT FOR ANOTHER USE

Comments in this group mainly express concern regarding the general wellbeing of ponies and ethical principles about the use of animals for human-centered recreational purposes. Comments also discuss perceived problems in the management and regulation of the treatment of animals generally and specifically, as well as rider safety. Nearly 80 percent of the comments in this group recommend specific alternatives to a pony riding concession. While most of these comments advocate for a completely non-animal use, several comments recommend other animal-related activities, primarily animal sanctuaries or rescue/adoption centers.

Observations Moving Forward

The initial feedback received by RAP was open-ended and was not conducted as a statistically valid survey representing the mix and diversity of residents and park users in the City. It does, however, start to paint a picture of the issues that are most important to the community and helps to serve as a starting point for discussions in the current outreach effort.

Many of the comments offered suggestions that related to the need to provide an educational component, made requests for better management and oversight of any new vendors and called for accountability of new vendors to the City and the community. This feedback was used to develop the RAP Priorities and Considerations that are serving as the overarching guideposts for the review and consideration of new uses.

Appendix C.

RAP Board Presentation #1

September 7, 2023



Reimagining the Griffith Park Pony Ride Site

City of Los Angeles

Recreation and Parks Commission Board Meeting

September 7, 2023



Background

- The Pony Rides were a popular attraction in Griffith Park over the past 75 years
- RAP Pony Ride concession expired in December 2022 and was not renewed
- Based on feedback from the City Council, the RAP General Manager initiated a new process to re-imagine future recreational and educational activities on the site

Project Tasks

- » Historic Resources Assessment
- » Focus Group Meetings (up to 10)
- » Community Workshops (2)
- » Online Survey
- » Public Opinion Poll (statistically valid)
- » Pop-ups (4)
- » Best Practices Research
- » Rec and Parks Commission Meeting Attendance

RAP Priorities and Considerations

RAP has received and reviewed over 1,000 comments, emails, and letters from members of the public (Feedback Form now closed)

Comments generated a set of RAP goals and considerations for future projects that will be used to review the appropriateness of future uses (how do they respond to the RAP priorities and considerations?)

RAP Future Use Priorities

- Youth and Family-oriented
- Affordable (with a focus on low-income and underserved communities)
- Accessible
- Educational
- Fun!

Other Considerations



- Compatibility with existing and planned attractions in Griffith Park
- Priority Audience
- Accountability
- Cost, maintenance, liability
- Timeframe to implement

How We Are Engaging the Public



Future Use of the Griffith Park Pony Ride Site: Opportunities to Engage

Goal: Identify a fun, family-friendly, affordable, accessible, and educational future use to operate at the Pony Ride site.

	PHASE I	PHASE II	PHASE III
	LISTENING AND VISIONING Fall 2023	CONSIDERING OPTIONS Winter 2023 /Spring 2024	NEXT STEPS Spring 2024
 WHAT WE'RE TALKING ABOUT	<ul style="list-style-type: none"> Comments received so far: the community's priorities and concerns. An overview of the current visioning process, what decisions are being made, and how the public can engage. Goals that will be considered in the process of identifying options for the site. The criteria we will use to evaluate options being considered. 	<ul style="list-style-type: none"> What we heard: An overview of survey results, public comments, and focus group feedback. Presentation of potential options that will be presented to the Board to consider: did we miss anything? Gather input and feedback on options to share with Recreation and Parks Board. 	<p>We will present a summary of public feedback from all surveys and potential options for the Recreation and Parks Board of Commissioners and City Council to consider.</p> <p>The Board of Commissioners and City Council may recommend one option and request staff move forward with the process to identify a vendor, or they may ask staff to evaluate more than one use and return with more information before making a final action.</p>
 HOW TO PARTICIPATE	<ul style="list-style-type: none"> Initial Online Feedback: 940 comments and emails received since December 2022. New Online Survey: A new survey will be conducted in English and Spanish to learn more about the community's priorities, preferences and concerns. Focus Group Meetings: Listening sessions with local groups and organizations. Pop-ups: In-person events - more info to come! Community Workshop: A workshop to gain insights on uses to consider and ways to meet RAP goals. 	<ul style="list-style-type: none"> Opinion Poll: A random sample of residents will be contacted online or by phone as part of a statistically-valid poll. Community Workshop: A second workshop will be held to share public input and receive feedback on options under consideration. 	



Four pop-up events will be held across the City. Come share your vision! Dates and locations to be announced.



OTHER STUDIES

A team of historic preservation experts is evaluating the site's historic value and features that may be integrated into future uses. The project team will also conduct research on best practices for youth and family recreation activities in the region and nationwide to use as comparison.



FOCUS GROUP OUTREACH We will meet directly with groups including:

- Griffith Park Advisory Board
- LA Alliance for Animals
- LA Equine Advisory Committee
- Friends of Griffith Park
- LA Equestrian Coalition
- Parents and Families
- Faith and Community Based Organizations

For more information visit: www.laparks.org/griffithpark/pony-rides or email comments to: rap-reimaginingtheponyride@lacity.org

General Timeline and Process

September 2023

- Focus Group Meetings
(currently underway or scheduled)

October 2023

- Focus Group Meetings
 - CBOs
 - Faith-based Organizations
- Historic Resource Assessment

November 2024

- Community Workshop #1
- Online Community Survey (Spanish and English)
- Pop-ups

Winter 2023/Spring 2024

- Remaining Pop-ups
- Public Opinion Poll
- Community Workshop #2
- Recreation and Parks Board of Commissioners Meeting
- City Council

Note: Timeline is tentative and subject to change.





For Questions, Comments or to Sign up for Notifications

Website:

www.laparks.org/griffithpark/pony-rides

Email:

rap-reimaginingtheponyride@lacity.org

Appendix D.

RAP Board Presentation #2

February 15, 2024



Reimagining the Griffith Park Pony Ride Site

City of Los Angeles

Recreation and Parks Commission Board Meeting

February 15, 2024



Background

- The Pony Rides were a popular attraction in Griffith Park over the past 75 years
- RAP Pony Ride concession expired in December 2022 and was not renewed
- Based on feedback from the City Council, the RAP General Manager initiated a new process to re-imagine future recreational and educational activities on the site

Project Tasks

- » Historic Resources Assessment
- » Focus Group Meetings
- » Community Workshops
- » Online Survey
- » Public Opinion Poll (statistically valid)
- » Pop-ups
- » Best Practices Research

Outreach Completed

Statistically Valid Telephone and Online Survey of Residents

February 2024

- Over 500 residents
- Telephone and invite-only online survey

Pop-Up Booths

December 2023 through January 2024

- Talked to over 350 park-goers
- Locations across the city including:
 - Shane's Inspiration Playground at Griffith Park
 - Griffith Park Railroad #1
 - Discovery Cube
 - Lincoln Park
 - Pan Pacific Park
 - Westchester Recreation Center
 - Griffith Park Railroad #2
 - Sherman Oaks Castle Park
 - Westwood Recreation Center
 - Saboroff Sports Field at EXPO Center

Focus Group Meetings

September through October 2023

- Seven meetings:
 - Los Angeles Equestrian Coalition
 - Los Angeles Equine Advisory Committee
 - Los Angeles Alliance for Animals
 - In Defense of Animals,
 - PETA
 - Animal Legal Defense Fund
 - Griffith J Griffith Trust, Friends of Griffith Park
 - Griffith Park Advisory Board
 - Los Feliz Improvement Association
 - Los Feliz Neighborhood Council
 - Hollywoodland Gifted Park
 - Motherhood Alliance Equity Village Empowerment (MAEVE) Los Feliz

Online Survey Public Comments

December 2022 through June 2023

- Over 1,000 comments
- Summaries and comments posted online



Emerging Ideas

- Seeing valid comments from both perspectives
 - Need for transparency
 - Modernize operations (any use)
 - “Natural” versus “Urban” type uses
 - General interest in wellbeing for animals
- May be opportunities to combine a variety of uses to create a new district or destination in Griffith Park

What's New & What's Next

Community Open House

March 6th, Friendship Auditorium

From 5:30 pm - 8:30 pm

New Online Survey

Survey opens February 19 and closes March 22, 2024

- Same questions that were asked in the random telephone and invite- only online surveys

Historic Structures Report

Completed and will be posted to the website in the upcoming week





For Questions, Comments or to Sign up for Notifications

Website:

www.laparks.org/griffithpark/pony-rides

Email:

rap-reimaginingtheponyride@lacity.org

Appendix E.

Summary of Focus Group Comments

February 7, 2024





Reimagining the Griffith Park Pony Rides Site

Focus Group Meetings: Summary of Key Takeaways

February 7, 2024

Introduction

A series of six focus group meetings were held with a variety of community organizations in September and October of 2023. The groups provided their insights about the future use of the Pony Rides site. Below is a summary of notes about what participants shared during these focus groups meetings. These serve as high level reporting out of ideas shared, and do not represent direct transcriptions of conversations, and do not represent any formal recommendations of the focus group participants or opinions held by RAP or PlaceWorks.

Each group was asked the same set of questions:

- What do you/your group believe to be the biggest opportunities for reuse of the site moving forward?
- Who do you/your group feel the audience to be served should be?
- What uses would you/your group recommend for reuse on the site?
- What do you/your group feel are the biggest considerations or lessons learned should be kept in mind for future uses?
- Are there other groups/audiences that we should be reaching out to?
- What other things would you like to share with RAP as we move forward in this process?

Key Takeaways from Focus Group Meetings

LA Equestrian Coalition Meeting

September 1, 2023

- Key Considerations
 - Vital community benefit
 - Care for ponies comes first (animal welfare)
 - Educational, therapeutic, mental health, and social/emotional benefits of human-animal interaction
 - Multicultural and multilingual priorities (specifically low-income communities of color)
- Ideas Shared
 - “Children’s Gold-Standard Pony Experience” concept
 - Include educational components (possibly while waiting in the line to enter)
 - Create facilities for special needs/neurodivergent park goers (read aloud to a horse, non-judgmental audience)
 - Large thermometer to measure when ponies can/cannot work
 - Consider use of composite rubber flooring, shade structure over entire area (also required by law to address heat and climate change)
 - Underwriting for an endowment/trust and equestrian licensing fund
 - Murals, shade sails, color, art

- General
 - Didn't go wrong, but in operation for 75 years and just didn't evolve
 - Needed checks and balances on processes (upgrade from physical tracking to computer, etc.)
 - Nowhere you can take toddler (1-2 years) that is animal-specific
 - There is an opportunity to create multilingual educational exhibits for patrons waiting in line
 - Equus Outreach program as model
 - Programming for at-risk teens
 - Ensure consistent oversight of concessionaires (cleanliness and service)
 - Examples (Las Vegas, San Bernardino County, Ventura)
 - Undocumented families may not be willing to fill out a survey but are a big user group
 - Equestrian community can fundraise

LA Equine Advisory Committee

September 11, 2023

- Key Considerations
 - Reposition and reimagine; not just as entertainment
 - Mission – demonstrating and teaching about animal welfare
 - Recommend the “5 domains system” of animal welfare assessment.
 - Use the site to demonstrate and teach exceptional care.
 - Therapeutic benefits (especially neurodivergent youth)
 - Pony and Petting Zoo
 - Consider pony demonstrations: ferries, braids for shows, etc.
- Ideas Shared
 - Include history, STEAM opportunities: evolution, ecology, animal classification, etc. in educational component.
 - Care and health records need to be transparent
 - There are different standards of care in the equine community, including the appropriate methods to feed animals, that should be further explored
 - Cost to use is important (private lessons can be \$80 per hour vs. \$5 pony ride)
 - Want a safe venue “no-bullying zone”
 - 3rd party veterinarian spot checks
- General
 - Concrete, pavement-based activities don't support Griffith J. Griffith's vision
 - Human/animal interaction can help with empathy, patience, motor skills and balance
 - Minimum standards of care are legal federal/state minimum standards. Most horse owners care for their horses better than the minimum standard: beyond the minimum standards, there are "Gold Standards"
 - Not just “ponies in circles” – housed safely, interactions benefit animals and users
 - Often serve as entry point/first step to becoming an equestrian
 - Include choice, behavioral enrichment
 - See “Taking Reins” as a good example of inner-city enrichment program with a good track record

Friends of Griffith Park & Griffith J. Griffith Trust

September 20, 2023

- Key Considerations
 - Would like state-of-the-art equestrian experience with riding and improved oversight (Friends & Trust support this)
 - How to care for ponies
 - Attendants better educated about children's safety
 - Backyard stable (also for therapy)
 - Should contain educational components
 - Multicultural significance for various local communities with equestrian traditions
 - Maintain consistency with Griffith's vision for urban wilderness
 - Equestrian tradition important to members of Latino and Black communities
- Ideas Shared
 - Encourage unannounced vet visits
 - Create a safe venue where people can enjoy equestrian activities without judgement
- General
 - Group feels that Griffith Park Vision (2014) was not a good document
 - Commercialization of the park
 - Re-wrote the master plan (urban wilderness)
 - Would like state of the art equestrian experience
 - Pony rides are many kids' first introduction to Griffith Park; as they get bigger they evolve into hiking and other activities
 - Riding/volunteer opportunities for school kids
 - Picnic in place, hikers, walkers, and baby strollers still have space
 - There are few areas in Los Angeles where you can put child on an animal for a brief period of time
 - Lengthy queue lines demonstrated that it was a popular attraction
 - Would like trees/shade

Griffith Park Advisory Board (GPAB)

September 9, 2023

- Key Considerations
 - Compassion towards animals
 - Should have interaction with animals and horses specifically
 - Not committed to riding horses, but to providing equestrian experience of some kind
 - Education should be central and incorporate all kinds of local animal life
 - Sanctuary ok – never ridden
 - Could help teach about disabilities (rescued animals with ongoing special care needs)
 - Should be Family-friendly. However, family-friendly generally means kid-centric, but we should consider other family formations. "Kid Centric" should also not exclude others (married, retired, etc.)
 - One of the main questions to answer is if there are ponies: To ride or not to ride?

- Ideas Shared
 - Gentle Barn/Animal rescue (where animals are not ridden)
 - Theme-park style attraction highlighting urban wildlife in the park
 - Incorporate LA River (adjacent river access)
 - Train ride needs to relate in some way
 - “Adopt a Pony” – not committed to ride, committed to horses and children’s access to animals (Pony ride, Pan Pacific Park, goats, and chickens that people can feed)
 - Missing opportunity: snakes, coyotes, hawks/raptor program (barn owls, coopers hawks, ground squirrels). History of P-22, education of native and domestic animals (example: raccoon eating cat food)
 - Paint a pony, photography sessions, composting
- General
 - Against turnstile/pony sweep
 - Zoo expensive now, need to have a low-cost entry point
 - Indigenous people and histories are under-represented
 - Accountability and transparency are critical and desired by everyone
 - Journey of Water example from Epcot (imaginative, inclusive, not expensive)
 - If we had 100 ponies on site and just 40 giving rides, that would be ok. Some animals are domesticated to work, but the ponies did not have options. Should be that if the horse rejects, then they should be able to not give a ride that day. Problem was that the ponies were not treated well enough

Animal Advocates Meeting

October 17, 2023

Attending: Representatives from Los Angeles Alliance for Animals, In Defense of Animals, Animal Legal Defense Fund, and PETA

- Key Considerations
 - A non-animal model is preferred
 - There is no animal entertainment model that is humane. There are problems intrinsic to the model no matter the scale (business model benefits by number of rides given)
 - Animal exhibits are never a good idea because the needs of the animals will never come first
 - Animals in petting zoos live in a perpetual state of stress and are subjected to a constant barrage of strange noises and activities as many people try to touch them
 - Concern regarding zoonotic diseases; potential for transmissible diseases resulting from animal-human contact
 - Potential exposure of users to E. coli (see San Diego Fair) – is this a liability to the City?
- Ideas Shared
 - Who should use site: toddlers to 10 years of age
 - Something to do with kids on a Sunday such as:
 - Science/Reading Area
 - Archeology/dinosaurs

- Arts and crafts
 - Planting Trees, Community Gardening, Pottery
 - Pattern Wall
 - Ballet
 - Earthquake Testing
 - Mommy and me music interaction
- A reputable, accredited sanctuary puts the animals first. The public visits through carefully guided tours that do not cause the animals stress, highly structured environments, and animals have the choice to engage or not. Advocates believe a reputable animal sanctuary would not be possible at Griffith Park, where animals would be confronted by noisy crowds of strangers all day long, and therefore do not support this use in Griffith Park.
- Possibly explore expansion of Junior Ranger program (badges with educational programs, talk about animals in the park already such as owls and coyotes). See “agents of discovery” app.
- General
 - Animal exhibits are never a good idea; animal needs never come first and they teach children that it’s ok to confine them
 - Enforcement never happens; animal shelters are in crisis
 - No turnstiles – animals not happy walking in circles
 - Animals are in perpetual state of stress from everyone touching them
 - Takes a large amount of resources to manage effectively
 - Shared that a local Petting Zoo (seasonal) was under investigation for zoonotic pathogens and soil contamination
 - Concerns about equine cruelty, no water in heat, dirty water, pony lameness (from walking turnstile in same spot)
 - Examples referenced: Olympic Park, netting/shade structures in Encinitas Park (go above track)

Workshop: Friendship Auditorium Focus Group Notes

November 9, 2023

Attending: Community residents including members of the Los Feliz Improvement Association, Los Feliz Neighborhood Council, MAEVE Los Feliz, Hollywood Gifted Park

- Key Considerations
 - Attend to animals needs first and foremost
 - Animal-oriented history in Griffith Park (work horses, etc.)
 - Integration with train ride concession, history of trains as related to development of the area
 - Parents appreciate activities that offer supervised engagement for kids and allow them to take a break
 - Affordability is important
 - Rebuilding trust will be essential for any new concession
 - Opportunity to educate on food chain and farm-to-plate cycle, composting, etc.
 - Profit-driven businesses can compromise quality of life for the animals involved

- Everyone is against the “pony-go-round”/turnstile
- Opportunity to partner with veterinary education ; veterinarians are in short supply and it’s a field with serious minority underrepresentation. Exposure to animals at a young age is the #1 factor for entering the career path.
- Keep this area a natural environment and invest in more active uses in the riverside area of the park.
- “Reading to animals” programs
- Look at Underwood Family Farms (Thousand Oaks, apple picking, pumpkins), Lacy Park (ring to ride bicycles on a bike track), Sunset Stables – Paddock (Atwater) Irvine Park as models.
- Any pony experience needs a much larger number of ponies to ensure sufficient rotation and rest.
- One resident concerned about animal welfare (did not generally support animal-based uses) said that riding could potentially be ok if the animals came first, but does not believe that is possible in a for-profit business model.
- Any animal experience must be holistic; if riding is the only way kids interact with the animal, they don’t learn to consider the animal’s existence beyond riding it.
- Helmets and safety are important.
- Age – focused on elementary school (up to 11-12, not teens)
- Maybe Senior Center Partnership?
- Ideas Shared
 - No turnstile/sweep
 - Gentle Barn
 - Animal rescue/education center (until people get an opportunity to interact with animals, they don’t understand them)
 - Equine/animal therapy center (with reading to animals)
 - Food lifecycle; farm to table (where does our food come from? This is how a farm works, how horses and cows are used, etc.)
 - Farm/garden with agricultural activities, fruit/vegetable picking
 - Zoo partnership/satellite area
 - Animal rehabilitation center with activities and education opportunities
 - Site with multiple nonprofit vendors operating different animal and wildlife education programs
 - Urban ecologist – hikes
 - Celebrate the biodiversity of Griffith Park – Wildlife rehab; bring in wildlife rescue site?
 - History around P22
 - Veterinarians? Gap medical access to pets? Partner with community colleges and expose kids to animals early on? Free vet care for low-income residents?
- General
 - This side of park is natural; better to support and enhance active recreation on the other side of the par
 - Potential for public private partnership and partnership with Autry Museum, indigenous peoples living history

Appendix F.

Open House Presentation - English

March 6, 2024





Reimagining the Griffith Park Pony Ride Site

City of Los Angeles

Community Open House

March 6, 2024

Presentations at 6:00 pm and 7:15 pm



Purpose of Tonight's Open House

- Provide overview of project background
- Provide overview of process and next steps
- Give the public an opportunity to provide input in person
- Provide a listening session to understand different ideas
- Generate awareness of next steps



Project Site



Approximately
the size of two
football fields

Located
adjacent to
the train rides



Background

- The Pony Rides were a popular attraction in Griffith Park over the past 75 years
- RAP Pony Ride concession expired in December 2022 and was not renewed
- Based on feedback from the City Council, the RAP General Manager initiated a new process to re-imagine future recreational and educational activities on the site

Project Tasks

- » Historic Resources Assessment
- » Focus Group Meetings
- » Community Workshops
- » Online Survey
- » Public Opinion Poll (statistically valid)
- » Pop-ups
- » Best Practices Research



RAP Priorities and Considerations

RAP received and reviewed over 1,000 comments, emails, and letters from members of the public on the initial survey

Comments generated a set of RAP goals and considerations for future projects that will be used to review the appropriateness of future uses (how do they respond to the RAP priorities and considerations?)

RAP Future Use Priorities

- Youth and Family-oriented
- Affordable (with a focus on low-income and underserved communities)
- Accessible
- Educational
- Fun!

Other Considerations

- Compatibility with existing and planned attractions in Griffith Park
- Priority Audience
- Accountability
- Cost, maintenance, liability
- Timeframe to implement



How We Are Engaging the Public

Reimagining the Griffith Park Pony Ride Site: Opportunities to Engage

Goal: Identify a fun, family-friendly, affordable, accessible, and educational future use to operate at the Pony Ride site.

	PHASE I	PHASE II	PHASE III
	LISTENING AND VISIONING <small>Fall 2023</small>	CONSIDERING OPTIONS <small>Winter 2023 /Spring 2024</small>	NEXT STEPS <small>Spring 2024</small>
 WHAT WE'RE TALKING ABOUT	<ul style="list-style-type: none"> Comments received so far: the community's priorities and concerns. An overview of the current visioning process, what decisions are being made, and how the public can engage. Goals that will be considered in the process of identifying options for the site. The criteria we will use to evaluate options being considered. 	<ul style="list-style-type: none"> What we heard: An overview of survey results, public comments, and focus group feedback. Gather input and feedback on options to share with the Board of Recreation and Park Commissioners. Did we miss anything? 	<p>We will present a summary of public feedback from all surveys and potential options for the Board of Recreation and Park Commissioners and City Council to consider.</p> <p>The Board of Recreation and Park Commissioners and City Council may recommend one option and request staff move forward with the process to identify a vendor, or they may ask staff to evaluate more than one use and return with more information before making a final action.</p>
 HOW TO PARTICIPATE	<ul style="list-style-type: none"> Initial Online Survey: 940 comments and emails were received at the close of the survey in December 2022. A summary of comments can be found on the website. Focus Group Meetings: Listening sessions with local groups and organizations. Pop-ups: In-person events held at parks and recreation centers. 	<ul style="list-style-type: none"> Opinion Poll: A random sample of residents will be contacted online or by phone as part of a statistically-valid poll. (Jan/Feb) New Online Survey: A new survey will be conducted in English and Spanish to learn more about the community's priorities, preferences and concerns. (Feb/Mar) Community Open House: An open house to gain insights on uses to consider and ways to meet RAP goals. 	
 POP-UP EVENTS	<p>Several pop-up events were held across the City between Dec 2023 and Jan 2024. Thanks to all who participated!</p> <p>A team of historic preservation experts is evaluating the site's historic value and features that may be integrated into future uses. The project team will also conduct research on best practices for youth and family recreation activities in the region and nationwide to use as comparison.</p>		
 OTHER STUDIES	<p>FOCUS GROUP OUTREACH We will meet directly with groups including:</p> <ul style="list-style-type: none"> Griffith Park Advisory Board LA Alliance for Animals In Defense of Animals Friends of Griffith Park PETA LA Equine Advisory Committee LA Equestrian Coalition Parents and Families Animal Legal Defense Fund Faith and Community Based Organizations 		

For more information and to join the mailing list, visit: www.laparks.org/griffithpark/pony-rides

Updated: 02/16/2024

General Timeline of Project

September 2023

- Focus Group Meetings

October 2023

- Focus Group Meetings
 - CBOs
 - Faith-based Organizations
- Historic Resource Assessment

December 2024

- Pop-ups

Spring 2024

- Remaining Pop-ups
- Public Opinion Poll
- Community Workshop
- Recreation and Parks Board of Commissioners Meetings
- City Council



Outreach Completed To Date

Online Survey Public Comments

December 2022 through June 2023

- Received over 1,000 comments
- Summaries and comments posted online

Focus Group Meetings

September through October 2023

- Seven meetings:
 - Los Angeles Equestrian Coalition
 - Los Angeles Equine Advisory Committee
 - Los Angeles Alliance for Animals
 - In Defense of Animals,
 - PETA
 - Animal Legal Defense Fund
 - Griffith J Griffith Trust, Friends of Griffith Park
 - Griffith Park Advisory Board
 - Los Feliz Improvement Association
 - Los Feliz Neighborhood Council
 - Hollywoodland Gifted Park
 - Motherhood Alliance Equity Village Empowerment (MAEVE) Los Feliz

Pop-Up Booths

December 2023 through January 2024

- Talked to over 350 park-goers
- Locations across the city including:
 - Shane's Inspiration Playground at Griffith Park
 - Griffith Park Railroad #1
 - Discovery Cube
 - Lincoln Park
 - Pan Pacific Park
 - Westchester Recreation Center
 - Griffith Park Railroad #2
 - Sherman Oaks Castle Park
 - Westwood Recreation Center
 - Soboroff Sports Field at EXPO Center

Statistically Valid Telephone and Online Survey of Residents

February 2024

- Over 500 residents
- Randomized telephone and invite-only online survey



Emerging Ideas

- Seeing valid comments from both perspectives
 - Need for transparency
 - Modernize operations (any use)
 - “Natural” versus “Urban” type uses
 - General interest in wellbeing for animals
- May be opportunities to combine a variety of uses to create a new district or destination in Griffith Park



What’s New & What’s Next

Now Open! New Online Survey

Survey opened February 19 and closes March 22, 2024

- The same questions that were asked in the random telephone and invite- only online surveys

Historic Structures Report

Completed and will be posted to the website soon

Evaluate Results

The team will review the public input gathered to evaluate what uses are desired by the community

Present Options to the Board of Commissioners

Decisionmakers will provide direction to staff regarding what steps to take



Tonight's Activities

- Two stations
 - **What would you like to see?**
 - Choose a photograph, make a note of what you like, would like to see more of
 - **What activities and experiences are most important to you?**
 - Attendees will each be given 5 dots
 - Place dots on things that are most important to you. You can place them all on one use or activity or split them up.
- Opportunity to take online survey



For Questions,
Comments or to Sign
up for Notifications

Website:

www.laparks.org/griffithpark/pony-rides

Email:

rap-reimaginingtheponyride@lacity.org



Appendix G.

Open House Presentation - Spanish

March 6, 2024





Reimaginando el sitio de paseo en pony de Griffith Park

Ciudad de Los Ángeles

Casa Abierta Comunitaria

6 de marzo de 2024

Presentaciones a las 6:00 pm y 7:15 pm



Objetivo de la Casa Abierta de esta noche

- Descripción general del historial del proyecto
- Ofrecer una visión general del proceso y de los próximos pasos
- Dar al público la oportunidad de hacer aportaciones en persona
- Ofrecer una sesión de escucha para comprender las diferentes ideas
- Generar conciencia de los próximos pasos

Sitio del proyecto



Aproximadamente el tamaño de dos campos de fútbol

Situado junto a los paseos en tren



Historial

- Los paseos en pony fueron una atracción popular en Griffith Park durante los últimos 75 años
- La concesión del RAP Pony Ride se venció en diciembre de 2022 y no fue renovada
- Basándose en la información recibida del Concejo Municipal, el Director General de RAP inició un nuevo proceso para reimaginar las futuras actividades recreativas y educativas en este sitio.

Tareas del proyecto

- » Evaluación de los recursos históricos
- » Reuniones de grupos focales
- » Talleres comunitarios
- » Encuesta en línea
- » Encuesta de opinión pública (estadísticamente válida)
- » Pop-ups
- » Investigación sobre buenas prácticas



Prioridades y consideraciones de RAP

RAP recibió y revisó más de 1,000 comentarios, correos electrónicos y cartas de miembros del público sobre la encuesta inicial.

Los comentarios generaron una serie de objetivos y consideraciones de PAR para futuros proyectos que se utilizarán para revisar la idoneidad para revisar la idoneidad de futuros usos (¿cómo responden a las prioridades y consideraciones del RAP?).

Prioridades de uso futuro de RAP

- Orientación juvenil y familiar
- Asequibles (con especial atención a las comunidades de bajos ingresos y desatendidas)
- Accesible
- Educación
- ¡Divertido!

Otras consideraciones

- Compatibilidad con las atracciones existentes y previstas en Griffith Park
- Público prioritario
- Rendición de cuentas
- Coste, mantenimiento, responsabilidad
- Plazo de tiempo para la implementación



Cómo involucramos al público

Reimaginando el sitio de Paseo en Pony de Griffith Park: Oportunidades de participación

Objetivo: Identificar un nuevo uso divertido, familiar, asequible, accesible y educativo de las instalaciones de Paseos en Pony.

FASE I	FASE II	FASE III
PLANIFICACIÓN Y VISIÓN <small>Otoño 2023</small>	CONSIDERACIÓN DE OPCIONES <small>Invierno 2023 / Primavera 2024</small>	PRÓXIMOS PASOS <small>Primavera 2024</small>
<p>DE QUÉ ESTAMOS HABLANDO</p> <ul style="list-style-type: none"> • <i>Comentarios recibidos hasta ahora: Prioridades y preocupaciones de la comunidad.</i> • <i>Una visión general del proceso actual de planificación, qué decisiones se están tomando y cómo puede participar el público</i> • <i>Objetivos que se tendrán en cuenta en el proceso de identificación de opciones para el lugar.</i> • <i>Los criterios que utilizaremos para evaluar las opciones que se consideren.</i> 	<ul style="list-style-type: none"> • <i>Lo que sabemos: Una visión general de los resultados de la encuesta, los comentarios del público y las opiniones de los grupos de enfoque.</i> • <i>Recopilar opiniones y comentarios sobre las opciones que hay para compartirlas con la Junta del Departamento de Recreación y Parques. ¿Nos hemos olvidado de algo?</i> 	<p>Presentaremos un resumen de los comentarios del público de todas las encuestas y las posibles opciones que hay para que la Junta del Departamento de Recreación y Parques y el Consejo Municipal las tengan en cuenta.</p> <p>La Junta y el Concejo Municipal pueden recomendar una opción y solicitar al personal que avance en el proceso de identificar un proveedor, o pueden pedir al personal que evalúe más de un uso y regrese con más información antes de tomar una acción final.</p>
<p>CÓMO PARTICIPAR</p> <ul style="list-style-type: none"> • Primeras encuesta en línea: Se recibieron 940 comentarios y correos electrónicos al cierre de la encuesta en diciembre de 2022. Se puede encontrar un resumen de los comentarios en el sitio web. • Reuniones de grupos de enfoque: Sesiones informativas con grupos y organizaciones locales. • Eventos emergentes: Actividades realizadas en parques y centros recreativos. 	<ul style="list-style-type: none"> • Encuesta de opinión: Se contactará en línea o por teléfono a una muestra aleatoria de residentes como parte de una encuesta con validez estadística. (Ene/ Feb) • Nueva encuesta en línea: Se realizará una nueva encuesta en inglés y español para conocer mejor las prioridades, preferencias y preocupaciones de la comunidad. (Feb/Mar) • Casa abierta comunitario: Una casa abierta para conocer los modos y usos que deben tenerse en cuenta para alcanzar los objetivos del Departamento de Recreación y Parques (RAP, por sus siglas en inglés). 	
<p>OTROS ESTUDIOS</p> <p>Se llevaron a cabo varios eventos emergentes en toda la ciudad entre diciembre de 2023 y enero de 2024. ¡Gracias a todos los que participaron!</p> <p>Un equipo de expertos en preservación histórica está evaluando el valor histórico del lugar y las características que pueden incorporarse a futuro. El equipo del proyecto también investigará las mejores formas de actividades recreativas para jóvenes y familias en la región y en todo el país, a modo de comparación.</p>	<p>GRUPOS DE ENFOQUE Nos reuniremos directamente con:</p> <ul style="list-style-type: none"> <li style="width: 33%;">Junta Consultiva del Parque Griffith <li style="width: 33%;">Alianza para los Animales de Los Angeles (LAAA) <li style="width: 33%;">Fondo de Defensa Legal Animal <li style="width: 33%;">Comité Asesor Equino de Los Angeles <li style="width: 33%;">Amigos del Parque Griffith <li style="width: 33%;">Comité Ecuéstre de Los Angeles <li style="width: 33%;">Padres y Familias <li style="width: 33%;">En Defensa de los Animales <li style="width: 33%;">Organizaciones religiosas y comunitarias <li style="width: 33%;">Personas para el Tratamiento Ético de Animales (PETA) 	

Para obtener más información y unirse a la lista de correo, visite la página web: www.laparks.org/griffithpark/pony-rides

Fecha de la última actualización: 16/02/2024

Plazo de tiempo general del proyecto

Septiembre de 2023

- Reuniones de grupos de enfoque

Octubre de 2023

- Reuniones de grupos de enfoque
 - OCB
 - Organizaciones religiosas
- Evaluación de los recursos históricos

Diciembre de 2024

- Pop-ups o Ventanas de Diálogo

Primavera de 2024

- Pop-ups o Ventanas de Diálogo restantes
- Encuesta de opinión pública
- Taller comunitario
- Reuniones de la Junta de Comisarios de Parques y Actividades Recreativas
- Concejo Municipal



Actividades de difusión realizadas hasta la fecha

Encuesta vía Internet Comentarios del Público

De diciembre de 2022 a junio de 2023

- Más de 1,000 comentarios
- Resúmenes y comentarios publicados en Internet

Reuniones de grupos de enfoque

De septiembre a octubre de 2023

- Siete reuniones:
 - Coalición Ecuestre de Los Ángeles
 - Comité Consultivo Equino de Los Ángeles
 - Alianza para los Animales de Los Ángeles
 - En defensa de los animales,
 - PETA
 - Fondo para la Defensa Legal de los Animales
 - Griffith J Griffith Trust, Amigos del Parque Griffith
 - Junta Asesora del Parque Griffith
 - Asociación para la Mejora de Los Feliz
 - Junta Vecinal de Los Feliz
 - Parque Hollywoodland Gifted Park
 - Motherhood Alliance Equity Village Empowerment (MAEVE) Los Feliz (Villa de Empoderamiento para la Alianza de Equidad Maternal)

Casetas para las Ventanas de Diálogo

De diciembre de 2023 a enero de 2024

- Hablamos con más de 350 visitantes
- En toda la ciudad:
 - Parque infantil Shane's Inspiration en Griffith Park
 - Ferrocarril de Griffith Park # 1
 - Cubo Discovery
 - Parque Lincoln
 - Parque Pan Pacific
 - Centro recreativo de Westchester
 - Ferrocarril Griffith Park # 2
 - Parque del Castillo de Sherman Oaks
 - Centro recreativo Westwood
 - Campo de deportes Soboroff en el Centro EXPO

Encuesta telefónica y vía internet de residentes estadísticamente válida

Febrero de 2024

- Más de 500 residentes
- Encuesta telefónica aleatoria y encuesta vía internet sólo por invitación



Ideas emergentes

- Viendo comentarios válidos desde ambas perspectivas
 - Necesidad de transparencia
 - Modernizar las operaciones (cualquier uso)
 - Usos de tipo "natural" frente a urbano
 - Interés general por el bienestar de los animales
- Puede haber oportunidades para combinar una variedad de usos para crear un nuevo distrito o destino en Griffith Park



Novedades

Ya está abierta Nueva encuesta vía Internet

Encuesta abierta el 19 de febrero y cerrada el 22 de marzo de 2024

- Las mismas preguntas al azar que se hicieron en las encuestas telefónicas y en las encuestas vía internet por invitación.

Informe sobre estructuras históricas

Finalizado y se publicará en breve en el sitio web

Evaluar los resultados

El equipo revisará las aportaciones públicas recogidas para evaluar qué usos desea la comunidad

Presentar opciones a la Junta de Comisarios

Los responsables de la toma de decisiones darán instrucciones al personal sobre los pasos a seguir



Actividades de esta noche

- Dos estaciones
 - **¿Qué le gustaría ver?**
 - Elija una fotografía, anote lo que le gusta, lo que le gustaría ver más
 - **¿Qué actividades y experiencias son más importantes para usted?**
 - Los asistentes recibirán 5 lunares cada uno
 - Coloca los lunares en las cosas que son más importantes para usted. Puede colocarlos todos en un mismo uso o actividad o dividirlos.
- Posibilidad de realizar una encuesta en línea



Para preguntas,
comentarios o
suscribirse a las
notificaciones

Página web:

www.laparks.org/griffithpark/pony-rides

Correo electrónico:

rap-reimaginingtheponyride@lacity.org



Appendix H.

Open House Summary

March 6, 2024





Reimagining the Griffith Park Pony Rides Site Community Open House: Event Summary

March 6, 2024

Overview

On Wednesday, March 6, 2024, the City of Los Angeles Department of Recreation and Parks (RAP) hosted a community open house for the Reimagining the Griffith Park Pony Ride Site effort. At the event, RAP provided an overview of the planning and decision-making process to identify new uses that could be established at the Pony Ride site. Community members also had opportunities to meet with RAP staff to ask questions, share their ideas on the future uses of the site through ideas board and prioritization exercises, take an online survey (there were 35 submittals), and fill out comment cards detailing more input that the City should consider in its conversations about the future of the site. Approximately 125 community members participated in the event.

Event Date: Wednesday, March 6, 2024
Location: Friendship Auditorium (3201 Riverside Drive Los Angeles, CA 90027)
Event time: 5:30- 8:30pm



Key Takeaways from the Community Open House

Prioritization Exercise

Attendees were provided three “dots” they could place on boards listing ideas that were popular from the prior public input RAP received regarding the most desired uses people would like to see at the site. Attendees could put all of their dots on one option or split them among various uses they would like to see.

While not intended to be an official vote, the exercise revealed there were two clear standout experiences that participants at this workshop were most interested in: a) bringing back the pony rides for children and b) creating sport courts and fields (it should be noted that there was a group of about 6-8 representatives advocating for new pickleball courts in attendance that night). Other options that people showed almost equal but lesser interest in were animal-related such as a petting zoo, activities that allow for interactions with horses where visitors don’t ride the horses (e.g. for mental health therapy and education), and animal rescues. Non-animal uses such as a community educational programs such as a nature center, a museum and community gardens with education components also garnered similar interest.

Community members were also able to add to the list of activities as additional options in the prioritization exercise on a separate board; examples of ideas that were added included roller skating, a bike track, and goat yoga. Attachment A, *Reimagining the Griffith Park Pony Rides Community Open House – Prioritization Exercise*, shows the different options attendees had to choose from and their preferences.

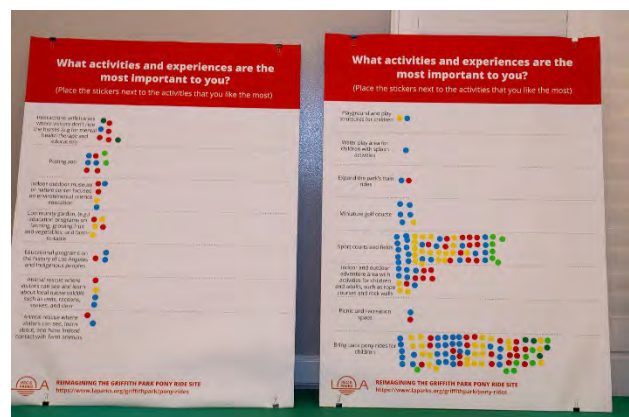
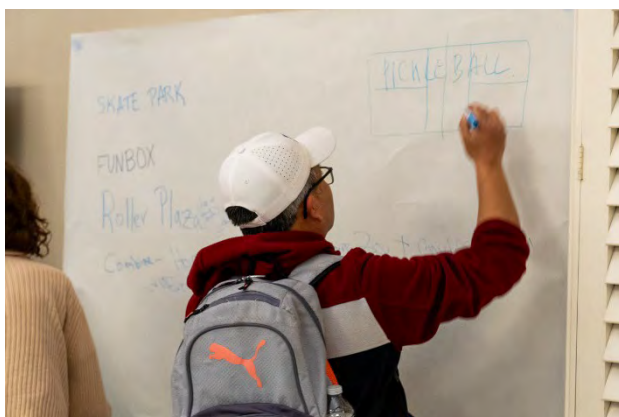

Ideas Wall

Attendees were given the opportunity to look through a series of photographs to choose one and provide comments on what they liked (or disliked) about the image and what they would like to see at the site. The exercise was intended to provide a forum for dialogue for the community's various interests and provided a platform for attendees to visualize new uses and better understand the interests of others in the City.

The following provides a summary of the general community sentiments shared at this station. Detailed community feedback received on the ideas board can be found in Attachment B, *Reimagining the Griffith Park Pony Rides Community Open House - Ideas Wall*.

- ***A fun, inclusive, family-friendly, and well-designed space:*** Participants commented that the new site should be fun and inclusive for people of all incomes and abilities. It should be family-friendly, with an emphasis for children. It should also be well-thought-out and properly planned, and the design should be context-appropriate (e.g. if there are animals, the space should be designed to provide the most comfortable environmental for the animals).
- ***Opportunities to Interact with Nature:*** Community members shared that the new use(s) should allow children to interact with nature and offer nature-type experiences.
- ***Water features:*** Participants selected many photos with water features such as splash pads and play equipment with water components.
- ***Educational programs:*** Community members provided many educational program ideas such as opportunities for children to learn about the local wildlife, internships for children to learn to care for animals, and creating a science center.
- ***Community programs:*** People noted that the site should offer community programs such as group yoga, drawing, art, singing, dancing, gymnastics, and martial arts.
- ***Honor native peoples.*** Participants commented on the cultural value of the land, and their desire to honor the native people that used space.
- ***Active recreation facilities.*** Several participants shared their preference for active recreation facilities such as pickleball and tennis courts, miniature golf, roller skating rink, and biking trails. Meanwhile, a handful of community members noted their opposition to those active recreation facilities.
- ***Advocating for and criticism of pony rides and interactions with animals.*** Some community members shared their interest to bring the back the pony rides. Others commented that RAP should have



activities that allow people to interact with animals such as equine therapy and petting zoo; however, the animals should have a high standard of care. There were also open house participants that would like RAP to not offer pony rides or programs/activities that involve ponies or other animal models.

Comment Cards

Community members were also given the opportunity to fill out comment cards to provide additional information or to elaborate on specific ideas expressed on the ideas boards. RAP received 25 comment cards at the community open house. General ideas shared through the comment card submittal are briefly summarized below and the specific comments received can be viewed in Attachment C, *Reimagining the Griffith Park Pony Rides Community Open House Comment Cards*.

- ***Family-friendly and affordable.*** Several participants wrote that they would like the new activity to be family-friendly (particularly for children), affordable, engaging and fun, and be available to community members in different age groups.
- ***Positive memories of the pony rides.*** A number of community members shared positive memories of participating in the pony rides, and they would like future generations to have access to the activity. The pony rides were affordable and were a unique experience to interact with animals in the middle of a large city. They expressed their desire for RAP to bring back the activity.
- ***Desire for a non-animal model.*** Some participants providing written comments expressed their concern for the wellbeing of the ponies and the way the ponies were treated at the prior pony rides. They noted that activities that involve ponies or animals are inhumane, and therefore the City should not bring back the pony rides.
- ***Alternate uses.*** Community members shared many other ideas to reimagine the pony ride site through non-animal model uses. Examples include water splash parks, community gardens, pickleball courts, exercise equipment, and nature walkthroughs like the one at Disney California Adventure.
- ***Suggestions for managing future uses.*** A small handful of comment cards were related to the planning and decision-making processes. These include the request for a transparent decision-making process on the future use(s) of the site and clarification of existing documents available on the project website.





**Attachment A:
Reimagine the Griffith Park Pony Rides
Community Workshop-Ideas Board Results**

What activities and experiences are the most important to you?

(Place the stickers next to the activities that you like the most)

Playground and play structures for children 

Water play area for children with splash activities 

Expand the park's train rides 

Miniature golf course 

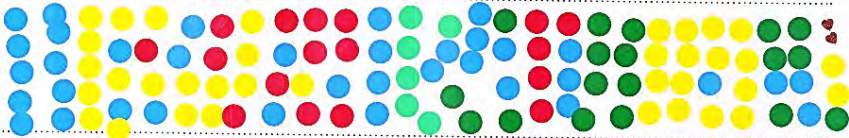
Sport courts and fields 

Indoor and outdoor adventure area with activities for children and adults, such as rope courses and rock walls 

Picnic and recreation space 

Bring back pony rides for children 

 **REIMAGINING THE GRIFFITH PARK PONY RIDE SITE**
<https://www.laparks.org/griffithpark/pony-rides>

What activities and experiences are the most important to you?

(Place the stickers next to the activities that you like the most)

Interactions with horses where visitors don't ride the horses (e.g for mental health therapy and education)



Petting zoo



Indoor-outdoor museum or nature center focused on environmental science education



Community garden, (e.g.) education programs on farming, growing fruit and vegetables, and farm-to-table



Educational programs on the history of Los Angeles and Indigenous peoples



Animal rescue where visitors can see and learn about local native wildlife such as owls, raccoons, snakes, and deer



Animal rescue where visitors can see, learn about, and have limited contact with farm animals



REIMAGINING THE GRIFFITH PARK PONY RIDE SITE
<https://www.laparks.org/griffithpark/pony-rides>

¿Qué actividades y experiencias son las más importantes para ti?

(Pon las pegatinas al lado de las actividades que más te gusten)

Interacciones con caballos en donde los visitantes no monten los caballos, incluyendo interacciones diseñadas para dar terapia de salud mental para niños y adultos, así como educación en cómo cuidar a los caballos

Un zoológico de observación

Un museo en espacio cerrado o al aire libre o un centro para la naturaleza que se enfoque en la educación de las ciencias del medio ambiente

Un jardín comunitario, incluyendo programas educativos en agricultura, cultivo de frutas y verduras y desde la granja a la mesa

Programas educativos en la historia de Los Ángeles y los pueblos Indígenas

Un rescate de animales en donde los visitantes puedan ver y aprender sobre fauna nativa local como búhos, mapaches, serpientes y ciervos

Un rescate de animales en donde los visitantes puedan ver, aprender y tener contacto limitado con animales de granja como, vacas, puercos, pollos, borregos y cabras



Reimaginando el sitio de paseo en pony de Griffith Park
<https://www.laparks.org/griffithpark/pony-rides>

¿Qué actividades y experiencias son las más importantes para ti?

(Pon las pegatinas al lado de las actividades que más te gusten)

Un parque infantil y estructuras de juego para niños

Un área de juegos acuáticos para niños con actividades de chapoteo

Expandir las atracciones de tren del parque

Un campo de golf miniatura/minigolf

Canchas y campos deportivos



Áreas de aventuras en espacios cerrados y al aire libre con actividades para los niños y adultos, como circuitos de cuerda y paredes de roca

Espacios para días de campo y recreación

Volver a poner los paseos en caballito/Pony Ride para los niños



Reimaginando el sitio de paseo en pony de Griffith Park
<https://www.laparks.org/griffithpark/pony-rides>



Attachment B:
Reimagine the Griffith Park Pony Rides
Community Workshop- Ideas Board



Top: The community provided a wealth of insights about the things that were important to them and the things that they'd like to see changed through the use of images and notes explaining what features were most appealing to them.

Bottom: There were several comments placed on the Image Board by one individual on behalf of a handful of participants at the workshop that shared similar interests.. These comments centered around the desire for a non-animal model and the preference to not see the pony rides return. Uses they preferred included outdoor recreational activities and educational activities for children such as train rides, picnics, and arts and crafts.

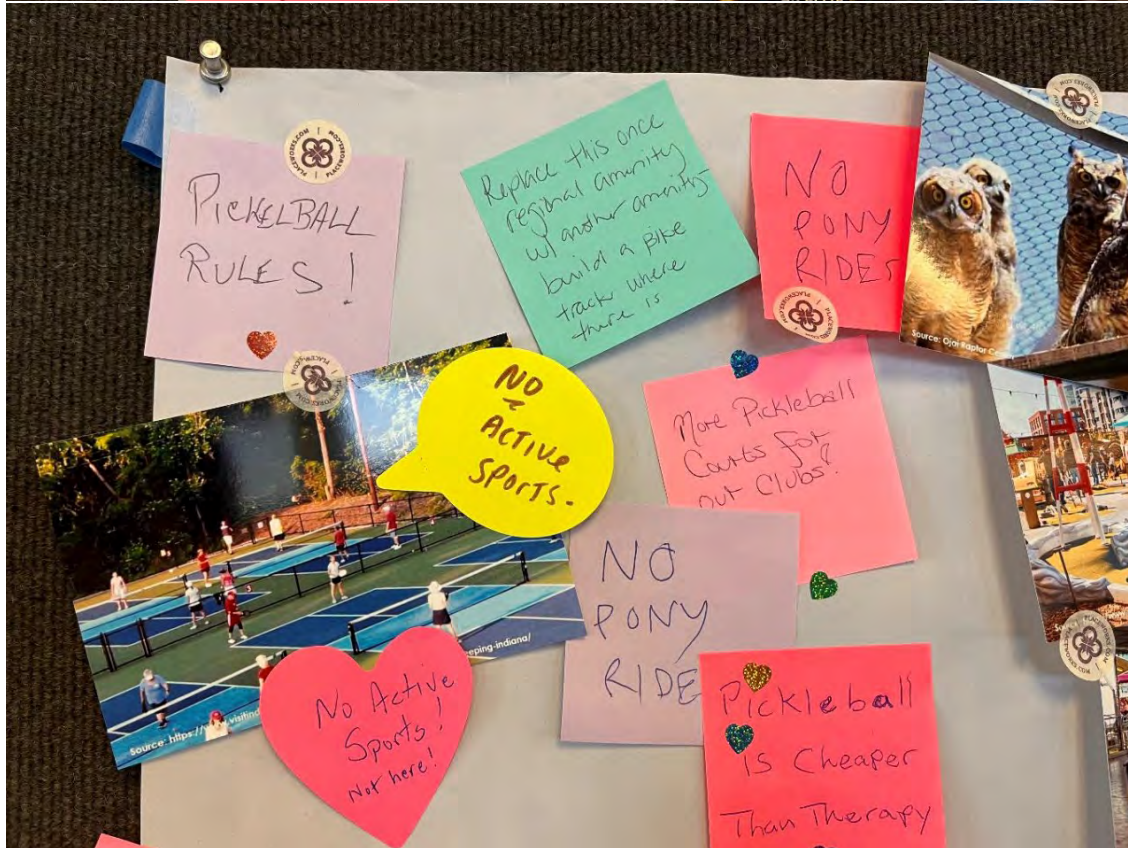
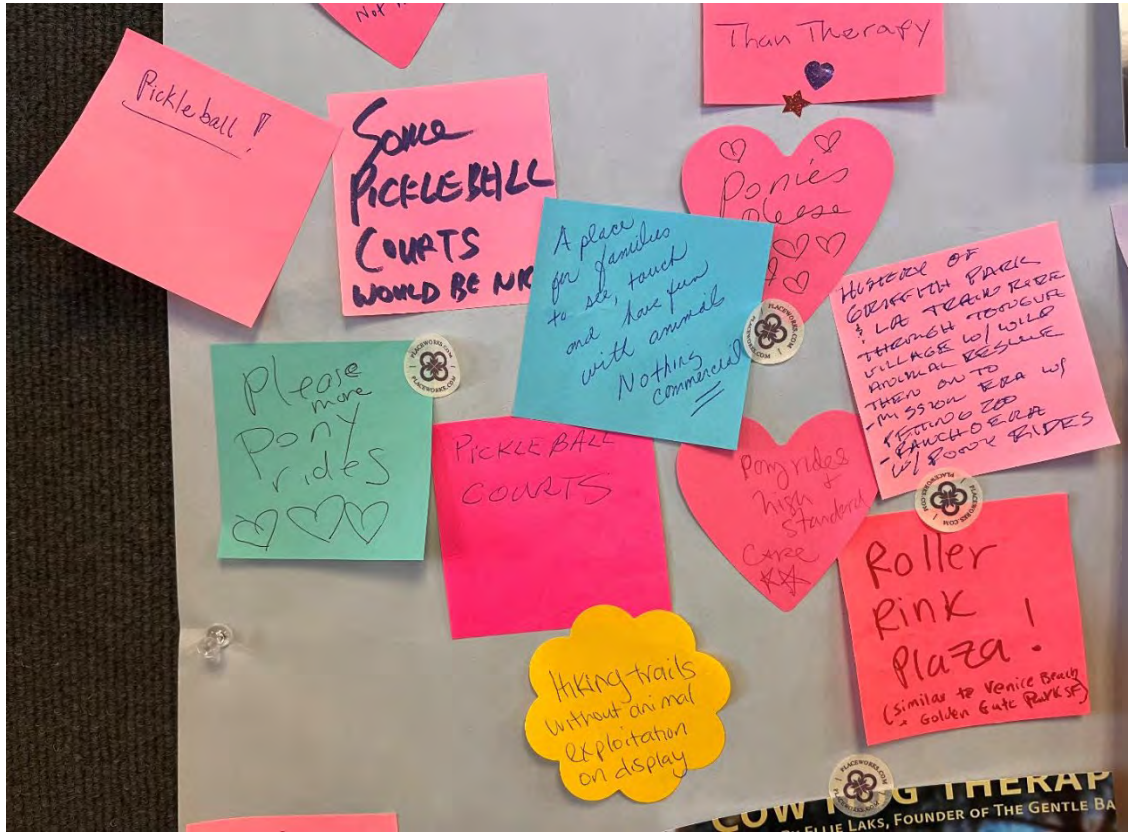





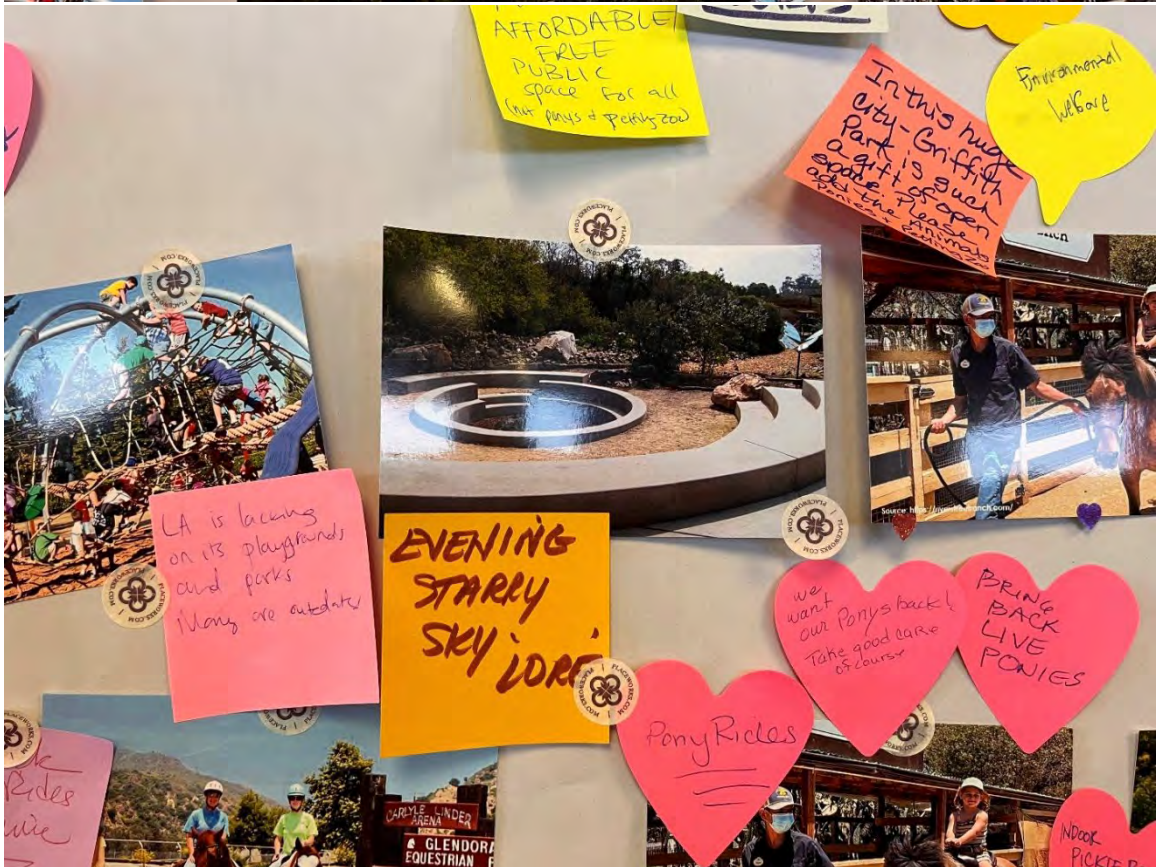
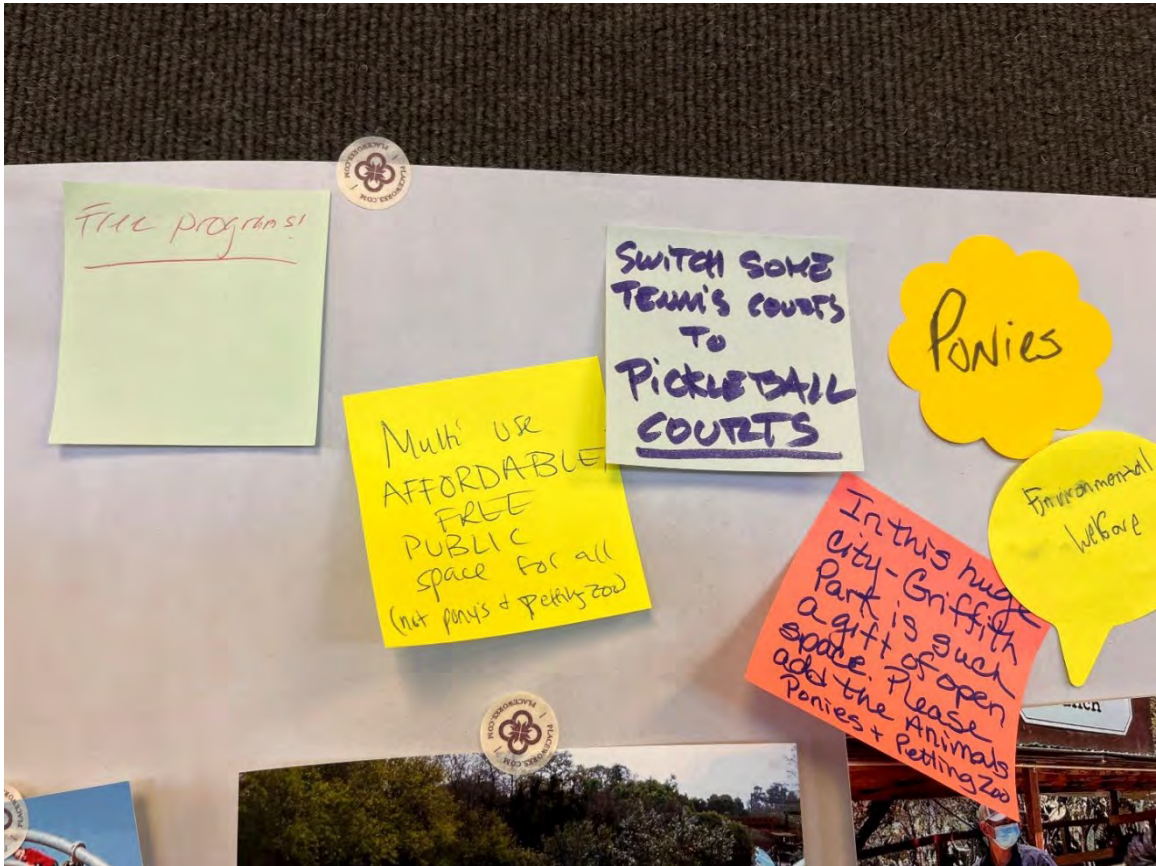











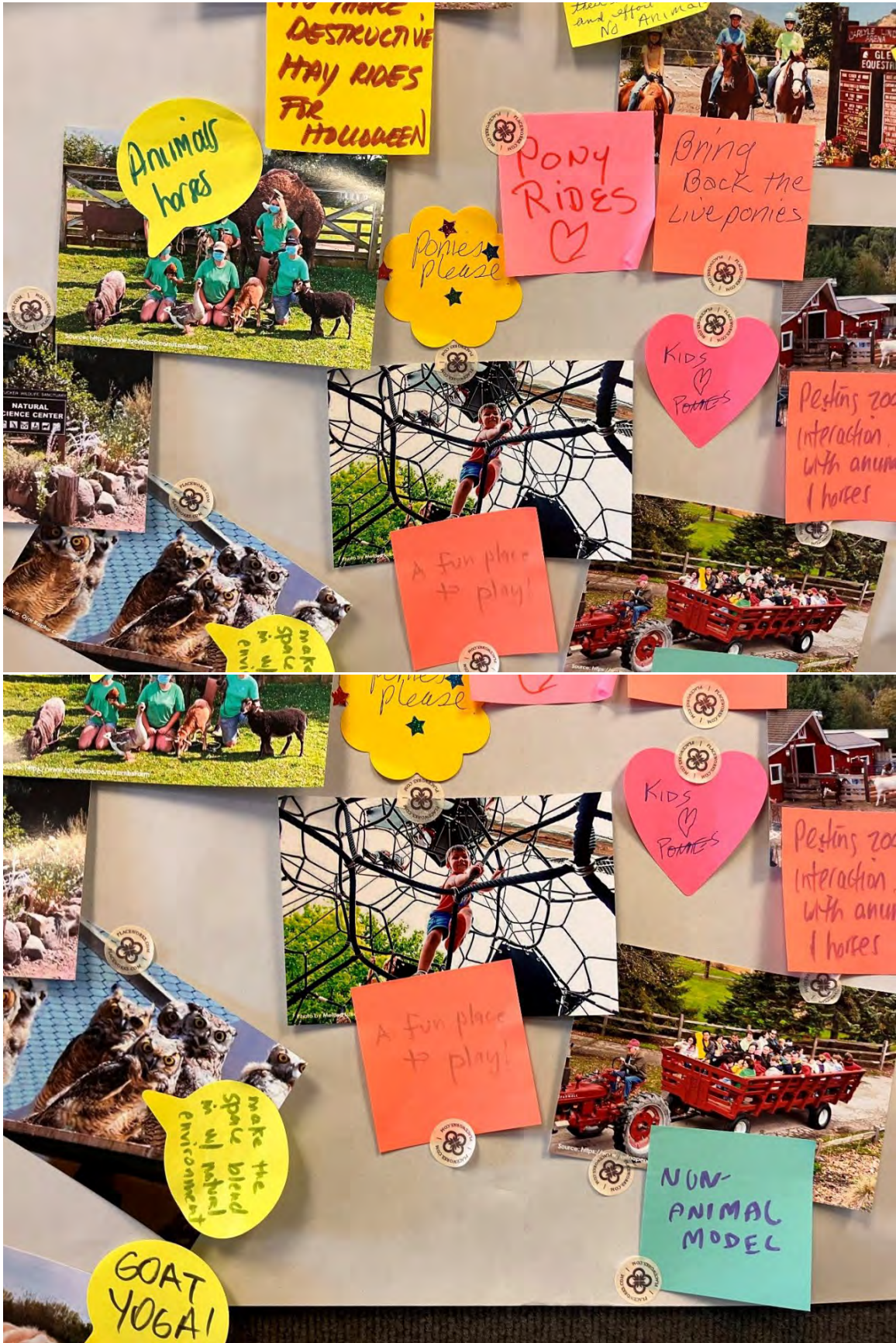

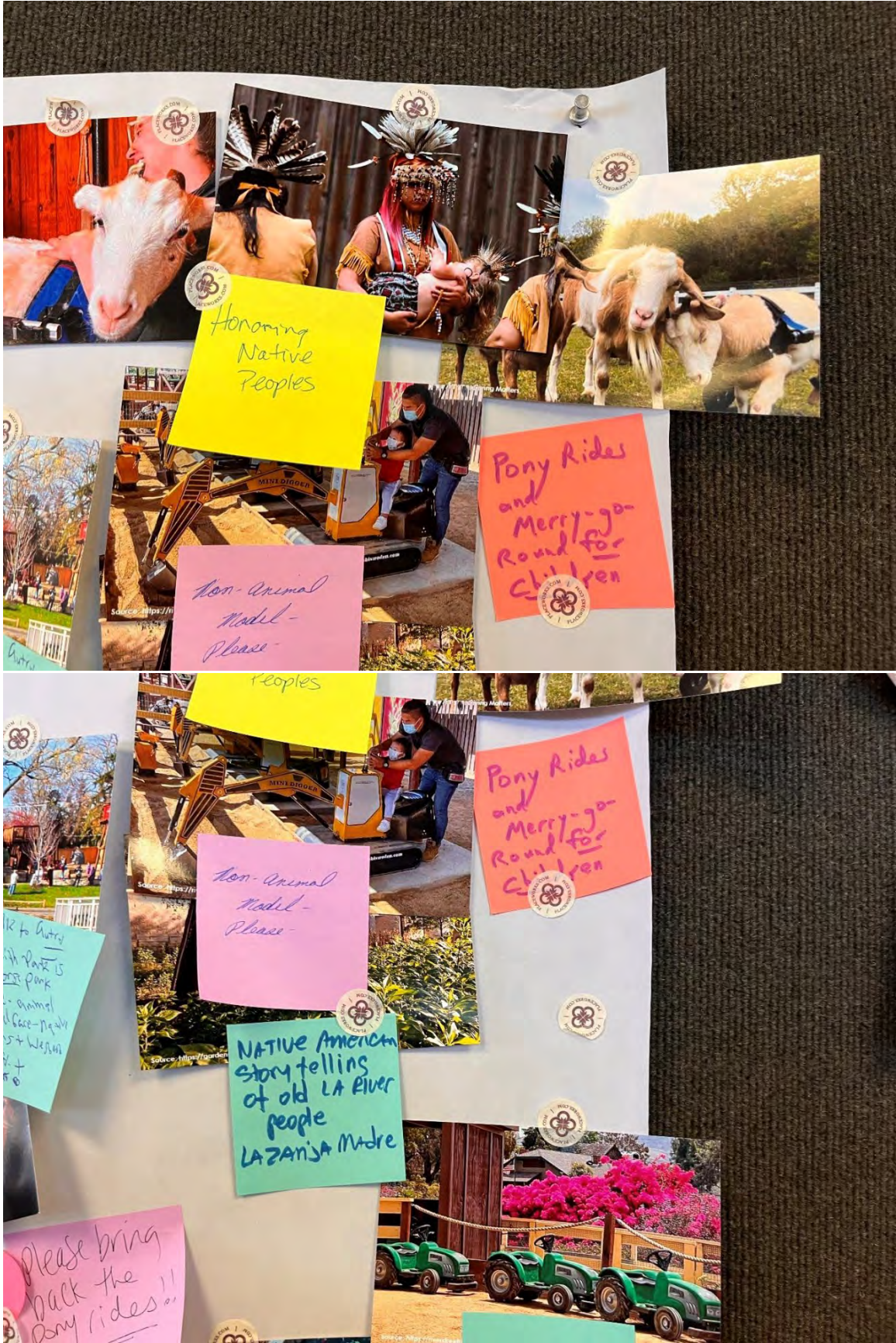

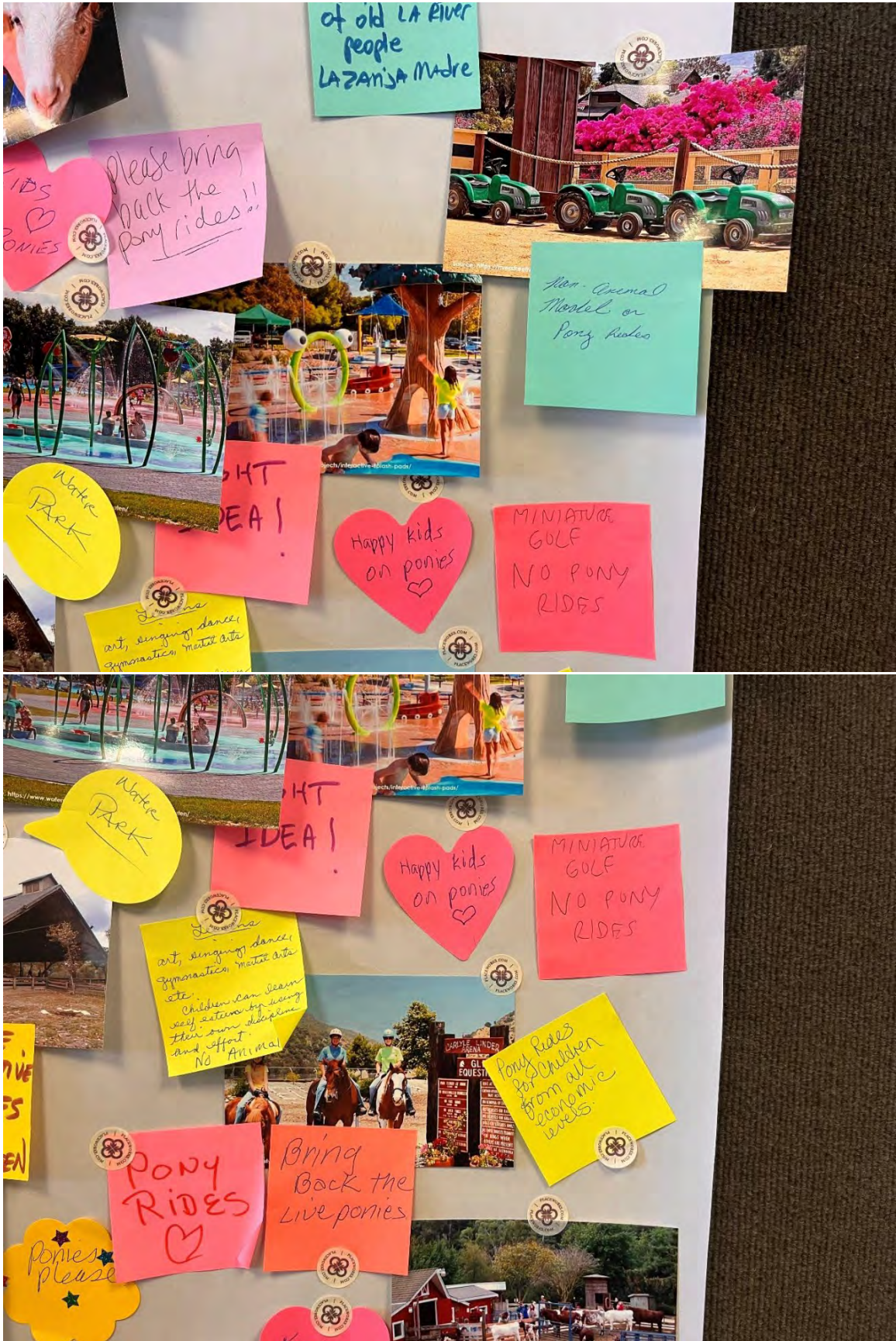

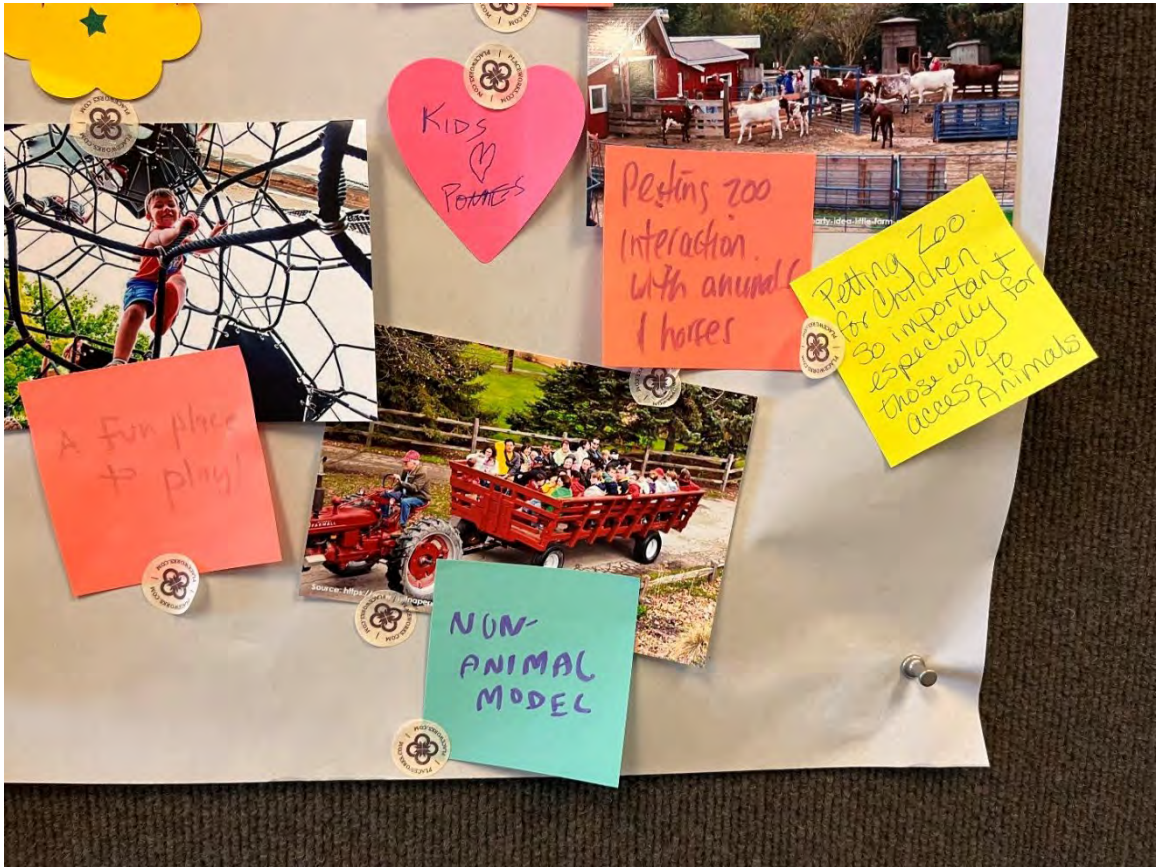







Attachment C:
Reimagine the Griffith Park Pony Rides
Community Workshop-Comment Cards

Reimagining the Griffith Park Pony Ride Site



PLEASE PRINT CLEARLY

Name: _____

Date: _____

Phone: _____

Email: _____

Mailing Address: _____

Comment:

I'm hoping the Pony rides are put back in place ASAP. They are part of the Park Heritage. Children-Families are needing this opportunity to enjoy, experience, learn from. Many great values learned from life long promoted love-respect of a horse-pony. Been an Equestrian All my life. Only positive to absorb from it. Very unique exp. we had^d had for our community. Especially in our in come.

Reimagining the Griffith Park Pony Ride Site



PLEASE PRINT CLEARLY

Name: _____

Date: _____

Phone: _____

Email: _____

Mailing Address: _____

Comment:

We need the pony rides back. My siblings & cousins all enjoyed these growing up. Future generations need this experience.

Reimagining the Griffith Park Pony Ride Site



PLEASE PRINT CLEARLY

Name: _____

Date: _____

Phone: _____

Email: _____

Mailing Address: _____

Comment:

WE SHOULD HAVE LEARNED VALUABLE LESSONS FROM THE PREVIOUS PONY OPERATOR. THE PONIES DID NOT RECEIVE ADEQUATE CARE.

PONIES, HORSES ARE EXTREMELY UPSET BY THE SOUND OF THE FREEWAY. A SOUND BARRIER MUST BE CONSIDERED FOR THEIR MENTAL → PHYSICAL HEALTH + WELLBEING →

Reimaginando el sitio de Paseo en Pony de Griffith Park



POR FAVOR ESCRIBE CLARAMENTE

Nombre: _____

Fecha: _____

Teléfono: _____

Dirección: _____

Correo electrónico: _____

Comentario:

The Background Fact #2 Needs to be removed. It is false. Wendy from Placworks said staff approved copy. Nov 2022 Matt from RAP staff sent letter to Steve Weeks APPROVING extension to contract. (Thank you files) Dec 2022 Jimmy Kim - BY HIMSELF - no public meet - RAP Commission meet - Closed DOWN PONY RIDES!

Reimagining the Griffith Park Pony Ride Site



PLEASE PRINT CLEARLY

Name: [REDACTED]

Date: [REDACTED]

Phone: _____

Email: _____

Mailing Address: _____

Comment:

An engaging, recreational model would fit into the established structure and existing concept of Griffith Park.

Adding any animal models will increase costs in maintenance and liability fees, and is therefore not desirable or effective for the community.

Reimagining the Griffith Park Pony Ride Site



PLEASE PRINT CLEARLY

Name: [REDACTED]

Date: [REDACTED]

Phone: [REDACTED]

Email: [REDACTED]

Mailing Address: [REDACTED]

Comment:

I am totally against the abuse of ponies & pony rides. The area can be reimagined by using existing community gardens teaching children about climate. There are ~~so~~ many areas to explore that are better for children.

Reimagining the Griffith Park Pony Ride Site



PLEASE PRINT CLEARLY

Name: [REDACTED]

Date: [REDACTED]

Phone: [REDACTED]

Email: [REDACTED]

Mailing Address: [REDACTED]

Comment:

Thanks for the presentation.
It is important to i for kids -
- to get physical & mental stimulation
- exercise
- good for diff. ages
- affordable
Teach kids kindness, not cruelty!

No Animals!
Thanks

If it ain't broke, don't break it!

Reimagining the Griffith Park Pony Ride Site



PLEASE PRINT CLEARLY

Name: [REDACTED]

Date: [REDACTED]

Phone: [REDACTED]

Email: [REDACTED]

Mailing Address: [REDACTED]

Comment:

Poor families have few, if any opportunities to allow their children to connect with horses and ponies. The pony rides provides a unique environment that's affordable for introducing young children to animals in the middle of a big city. The pony rides is nothing but positive for the city for the ponies and for the humans!

Reimagining the Griffith Park Pony Ride Site



PLEASE PRINT CLEARLY

Name: [REDACTED]

Date: [REDACTED]

Phone: [REDACTED]

Email: [REDACTED]

Mailing Address: [REDACTED]

Comment:

Please consider looking at the nature walk through in Disney California Adventure. This could be the perfect type of educational enrichment that Griffith Park needs.

Thank you! ☺

Reimagining the Griffith Park Pony Ride Site



PLEASE PRINT CLEARLY

Name: [REDACTED]

Date: [REDACTED]

Phone: [REDACTED]

Email: [REDACTED]

Mailing Address: [REDACTED]

Comment:

Riding on the backs of sentient beings as a means of entertainment is inhumane and damaging to the collective consciousness of human beings and detrimental to the wellness and physical health of ponies. Ponies suffer from hoof ailments, saddle sores, and mouth and teeth



Reimagining the Griffith Park Pony Ride Site



PLEASE PRINT CLEARLY

Name: [REDACTED]

Date: [REDACTED]

Phone: [REDACTED]

Email: [REDACTED]

Mailing Address: [REDACTED]

Comment:

Whatever choice is made, please be transparent both now & in the future. Losing the pony rides was very disconcerting due to the lack of transparency regarding why the permit was not renewed. It appeared that the owners made the necessary fixes and were lost their permit without an explanation. As part of the community it is frustrating to hear unsubstantiated claims of animal mistreatment and see a facility closed without documenting whether the

in addition to horse ride

Reimagining the Griffith Park Pony Ride Site



PLEASE PRINT CLEARLY

Name: [REDACTED]

Date: [REDACTED]

Phone: [REDACTED]

Email: [REDACTED]

Mailing Address: [REDACTED]

Comment:

I want a non animal model for the site due to the past abuses being inevitable. Disease, injuries and poor old animals. Pickleball seems like a great solution!

Reimagining the Griffith Park Pony Ride Site



PLEASE PRINT CLEARLY

Name: _____

Date: _____

Phone: _____

Email: _____

Mailing Address: _____

Comment:

PONY RIDES AND OTHER ANIMALS FOR ENTERTAINMENT DON'T FIT WITH THE LOS ANGELES HUMANE ETHIC. POOR WELFARE IS LIKELY TO COME BACK WITH A SIMILAR BUSINESS MODEL OF HIGH VOLUME OF KIDS WITH A LOW TICKET PRICE. PICK A HUMANE ATTRACTION EVERYONE CAN ENJOY.

Reimagining the Griffith Park Pony Ride Site



PLEASE PRINT CLEARLY

Name: _____

Date: _____

Phone: _____

Email: _____

Mailing Address: _____

Comment:

Water Parks for the kids They love it
"NO ANIMAL CRUELTY"

We the parents have to teach the kids
Compassion.

Reimagining the Griffith Park Pony Ride Site



PLEASE PRINT CLEARLY

Name: _____

Date: _____

Phone: _____

Email: _____

Mailing Address: _____

Comment:

I strongly oppose animal-model at Griffith park pony ride site. Any attraction where there is a high volume of visitors, animal's lives, welfare & overall well-being will be at risk and compromise High volume means animals will likely be exploited ~~and~~ exactly like how ~~the~~ the ponies were abused, neglected and worked to death from before

Reimagining the Griffith Park Pony Ride Site



PLEASE PRINT CLEARLY

Name: _____

Date: _____

Phone: _____

Email: _____

Mailing Address: _____

Comment:

Let's think out of the box!
Youth at Risk, Equine Education for kids
Adopt a pony, affordable "mini lesson" programs
therapy programs, w/ ponies

Reimagining the Griffith Park Pony Ride Site



PLEASE PRINT CLEARLY

Name: _____

Date: _____

Phone: _____

Email: _____

Mailing Address: _____

Comment: _____

BRING BACK THE PONIES

- ① CREATE A TRAINING MANUAL TO ENSURE PROPER TREATMENT OF THE HORSES
- ② DISPLAY THE EMPLOYEES CERTIFICATIONS (Picture No Name)
- ③ GET SUGGESTIONS FROM NO ANIMALS ON WHAT THEY WANT IN ORDER TO HAVE A SAFE OPERATION

Reimagining the Griffith Park Pony Ride Site



PLEASE PRINT CLEARLY

Name: _____

Date: _____

Phone: _____

Email: _____

Mailing Address: _____

Comment: _____

Send animal abuse at the ponyrides -
NON-animal model

Reimagining the Griffith Park Pony Ride Site



gmail.com

PLEASE PRINT CLEARLY

Name: [REDACTED]

Date: [REDACTED]

Phone: [REDACTED]

Email: [REDACTED]

Mailing Address: 5050 Sepulveda Blvd, S.O., CA 91403

Comment:

GOLDEN RULE APPLIES TO ALL LIFE FORMS
No pony rides & No Animal Model
Please, because any animal use
is animal abuse because animals
do not consent nor do they want
us to ride, use or abuse them. To ride
an animal, we need to kill their free spirit by
abuse. because animals don't give away freedom

for anyone as we don't either!

Reimagining the Griffith Park Pony Ride Site



PLEASE PRINT CLEARLY

Name: [REDACTED]

Date: [REDACTED]

Phone: [REDACTED]

Email: [REDACTED]

Mailing Address: [REDACTED]

Comment:

Non animal model - no pony rides -
- Pickleball courts -
- Water-splash park for kiddos -

Reimagining the Griffith Park Pony Ride Site



PLEASE PRINT CLEARLY

Name: _____

Date: _____

Phone: _____

Email: _____

Mailing Address: _____

Comment:

There are so many entertaining and esteem building opportunities for children & families in the Griffith Park space. It's time to evolve out of using animals. Watching the pony rides for over a year, I saw next to no interaction between children & ponies - in fact the children didn't even look the ponies in the face or relate to them in any way - many screamed and wobbled off!

Reimagining the Griffith Park Pony Ride Site



PLEASE PRINT CLEARLY

Name: _____

Date: _____

Phone: _____

Email: _____

Mailing Address: _____

Comment:

If animals, horses and ponies can talk, they would probably tell us that they don't want to walk around in circles, or work as entertainment in extreme heat. Please consider what animals want ~~and~~ into your decisions. There are so many options, you don't have to stick with pony rides.

Reimagining the Griffith Park Pony Ride Site



PLEASE PRINT CLEARLY

Name: _____ Date: _____

Phone: _____ Email: _____

Mailing Address: _____

Comment: _____

please bring back ~~an~~ a non-animal model
to the former pony ride site

children should learn that animals are not
here to entertain us or for us to use them
They are here with us - not for us

Reimagining the Griffith Park Pony Ride Site



PLEASE PRINT CLEARLY

Name: _____ Date: _____

Phone: _____ Email: _____

Mailing Address: _____

Comment: _____

PLEASE CONSIDER THE "GRIFFITH PARK PONY
EXPERIENCE" - A NEW WAY TO INTEGRATE
PONIES INTO THE HISTORICAL AREA &
STRUCTURES WITH AN UP-TO-DATE,
COMPASSIONATE STYLE & A GOLD
STANDARD OF CARE FOR THE PONIES

Reimagining the Griffith Park Pony Ride Site



PLEASE PRINT CLEARLY

Name: [REDACTED]

Date: [REDACTED]

Phone: _____

Email: _____

Mailing Address: [REDACTED]

Comment:

The document w/ the purpose of
the open house ~~is~~ needs a correction.
The pony rides permit was VALID
and extended to March 2023,
when Jimmy Kim unilaterally made
the decision to not renew the
contract. He did this under pressure →

Appendix I.

Pop-up Events Summary



Reimagining the Griffith Park Pony Rides Site Pop-up Events: Summary of Key Takeaways

Introduction

From December 2023 through April 2024, RAP staff talked to the community at spontaneous in-person pop-up booths at parks facilities across the city to gain firsthand, on-the-spot ideas and input from park visitors regarding the future of the Griffith Park Pony Rides site and the current process to re-imagine it. During that time, RAP staff spoke with approximately 400 parkgoers to share information about the effort and to ask the following questions:

- Did you hear about the Griffith Park Pony Ride closing?
- If you could make a change, what do you believe the closed Pony Ride Site should be used for in the future?
- Who do you think the area should be used by?
- Do you feel that the new activity should have a live animal experience or non-animal experience?
- What other things would you like to share with us about the future of the Pony Ride Site?

The pop-up booths also included an informal activity in which visitors were invited to write down on large posters indicating which zip code they live in and any thoughts they had about how they would like to re- envision the future of the Pony Ride Site. A children’s activity was also made available where younger visitors could draw what they would like to see at the site. The results of these activities are included as an attachment at the end of this summary.



Park visitors engaging with RAP staff regarding their thoughts about future uses for the Pony Rides site at a pop-up booth.

Where We Connected with the Community

Fourteen different pop-up locations were selected and staffed over the course of four months. They were held at various locations throughout the City in an effort to connect with the widest and most representative audience that had an interest in the future of the Pony Rides site.

Pop up locations included:

December 02, 2023	Shane’s Inspiration Playground at Griffith Park
December 02, 2023	Griffith Park Railroad – 1 st Visit
December 23, 2023	Discovery Cube
December 28, 2023	Lincoln Park
December 29, 2023	Pan Pacific Park
January 03, 2024	Westchester Recreation Center
January 05, 2024	Griffith Park Railroad – 2 nd Visit
January 05, 2024	Sherman Oaks Castle Park
January 05, 2024	Westwood Recreation Center
January 18, 2024	Soboroff Sports Field at EXPO Center
March 29, 2024	Algin Sutton Recreation Center
March 29, 2024	Jackie Tatum/Harvard Park
April 01, 2024	Echo Park Lake
April 01, 2024	MacArthur Park

Who We Interacted With

The pop-up booths had approximately 400 visitors who interacted with park staff regarding the Pony Ride site. The largest number of booth visitors interacted with were at the Griffith Park Railroad (the first visit in December 2023 had over 56% of the total pop-up booth interactions). Other popular locations Included Echo Park, Aiden’s Place and MacArthur Park.

APPROXIMATE NUMBER OF POP-UP BOOTH VISITORS BY LOCATION	
Griffith Park Railroad – 1 st Visit	219
Echo Park	40
Griffith Park Railroad- 2 nd visit	27
Westwood Aiden’s Place	27
MacArthur Park	22
Algin Sutton Rec Center	18
Jackie Tatum Harvard Rec Center	17
Westchester Rec Center	11
Expo Center	7
Total	388

Communities Affiliated with People Stopping by the Booth

We also wanted to get a better understanding of where our visitors providing input at the pop-ups were coming from. Not all visitors provided their zip code, but of the approximately 370 that did, following is a table representing the zip codes where staff talked to more than six participants:

Community	Zip Code	Approximate Number of Participants
Echo Park	90026	24
Lincoln Heights	90032	18
Vermont Vista	90044	16
Broadway-Manchester	90003	10
Hancock Park/Fairfax/Mid-Wilshire	90036	10
Sylmar	91342	9
Cypress Park/Glassell Park/ Mt. Washington	90065	8
East Hollywood/Larchmont/ Windsor Square/ Koreatown	90004	7
Downtown/ Pico Union	90015	7
Palms	90034	7
Westlake	90057	7

Key Takeaways from Pop-Up Events

Below is a summary of general comments and ideas participants shared during these pop-up events. This summary is intended to serve as a high-level overview of ideas shared by those that stopped by the booths, and should be used as one source for context in addition to the collective feedback received from other outreach efforts coordinated by the RAP Department on this project. The overview below is not representative of direct transcriptions of conversations with visitors stopping by the booth, nor does it represent a formal recommendation or opinions held by RAP or PlaceWorks. It is also intended to get a sense of the general sentiment of those interacted with and is not intended to serve as a statistically valid survey of ideas.

“What do you envision for the future of the Pony Ride Site?” Poster Board Activity

Participants were invited to provide their answers and zip codes on large poster boards and staff took notes with other visitors to record their ideas. Visitors answered in both English and Spanish. The general preference of visitors who participated in this activity leaned toward the inclusion of an animal experience alongside other uses including educational spaces, water activities, playgrounds, and a community garden.

Specific Ideas Shared	
<ul style="list-style-type: none"> • Humane Pony Ride • Animal Sanctuary Farm • Educational Farm/Petting Zoo • “Goat Yoga” • Interactive outdoor education experience – “how nature works” 	<ul style="list-style-type: none"> • Educational Purposes • Live animal experiences • Live animal experiences- birds • Water park • Playground • Basketball Courts/Rec Room/Arts and craft

<ul style="list-style-type: none"> • Playground “accessible for special needs kids” • Water Park • Paintball • Skate Park • Ropes Course • Basketball Courts • Rec Room • Expanded Train Rides • Educational Center • Bike trail and obstacle course • Outdoor Gym • Mini Golf • “Community Resource Center for Kids” • Soccer Complex • Public stage for kids • Cultural Site / History of Land / Multi-cultural Center 	<ul style="list-style-type: none"> • Sitting area for Parents • Maybe baby animals • Ziplines • Expand Train • Interactive farm for kids • Want merry-go-round back • Petting zoo • Sanctuary/farm • Sand pits • Obstacle course for kids • Roller skating • Mini golf • Something that compliments the zoo • Picnic areas • Friendship area for teens
--	---

General Summary of Insights from Conversations with Park Visitors

Participants held a wide range of opinions and shared many different ideas about the future of the Pony Ride Site and how it should be used in the future such as:

- Participants generally indicated support for family-friendly recreational uses with educational and entertainment components.
- Approximately 79% of those interacted with (218) indicated support for a live animal experience of some sort (approximately 34% wanted to see the pony rides come back).
- 8% of participants indicated support for a live animal experience *and* added that their support is conditional on the humane treatment of animals and a high standard of care (21 mentions).
- Approximately 12% of those interacted with (48) indicated support for a non-animal experience.
- Approximately 10% of those asked (37) gave an unclear or undecided response regarding an animal/non-animal experience.
- Participants were generally open to the idea of including a combination of uses on the site (versus selection of a singular use only), including suggestions such as: creating multiple animal-oriented experiences, pairing an animal experience with a non-animal experience, or grouping multiple non-animal uses.
- General sentiment among participants indicated preference for a use that kept the area relatively undeveloped and highlighted the “natural” qualities of the site.
- Participants generally liked the affordability of the previous Pony Rides use.
- Participants indicated that any potential animal use should consider and prioritize animal well-being.

Note: The total numbers don’t add to 388 respondents, since some people expressed interest in bringing back pony rides or said “no to pony rides” and offered suggestions for other activities. Very few people stated solely “No to Pony Rides. Instead, many people provided a range of ideas that included the reuse of the site with animal-related and non-animal related uses such as petting zoo, bike, housing, racquetball etc.

What do you envision for the future of the Pony Ride Site?

Please Leave Your Zipcode

1. Would Like pony Rides Back and petting Zoo, add merry go around in all one place with shops for kids. 90660

2. Would love the following

1) pony rides!

2) Merry go round

3) more animals (petting zoo on weekends)

4) Animal feeding

5) ~~Education~~ Animal Education for kids
zip: 90035 (mid city)

Animals Education
90003

ID: quiero que siga los caballos

Centro educacional sobre animales para niños. 90057

Aprender a cultivar.

90042

1. Hope to see petting zoo for the children.

2. Bring back the pony ride

Bring back the pony ride.

91201

BRING BACK THE PONIES!

* Educational + interactive space with animals in our area

3: IF THE HORSES ARE NOT BEING ABUSED FOR THE SAKE OF ENTERTAINMENT. 1/2 THE TIME IS MORE THAN ENOUGH

4. Please bring back the pony rides + add petting zoo. maybe with more consideration for the animals. We really miss this.

5. Bring the Pony rides back.

6. ~~Would~~ love to see no live animals at that location (no pony rides and no petting zoo), but rather build upon the remaining physical infrastructure to have a different experience (walk-through labyrinth? maze? rides?)

7. Splash pad, shade, benches with a changing area

8. quiero que aigan caballos

9. Please bring the ponies back, let the kids donate to the ponies & learn more about them & ride them.

10. I miss Freckles!



11. BRING PONY RIDES BACK, WITH MERRY GO ROUND SO ITS CONVENIENT FOR THE KIDS.

12. Please bring the ponies back,

What do you envision for the future of the Pony Ride Site?

Please Leave Your Zip Code

#PowerToThePonies
#BringThemBack
91306

Bring the ponies back for the kids!
90065

pony bring back, please
FOR KIDS 91205.

Bring the Ponies Back!! 90011

Please bring the ponies back! 91101
playground!

Bring the ponies back!
90044

91775
Playgrounds ->
& play structures
w. water feature in Summer

91205
Please, we need
playground for kids

Gardening for kids
Lessons on growing
crops
91501

91303
Please bring pony rides
back!!
Petting zoo would be
awesome too!

PLEASE BRING THE PONIES BACK
91011

91303
Please bring pony rides
back & splash pad for
Summer

91101
Please bring pony rides
back

Fast
gok art! 90012

Add lights!
90016

Bring back the ponies!
90012

90005
Teresa's play
area for
kids
90005
Bring back the ponies!
90006

make the dog zoo
for cats, animals,
and dogs. 9103

COMMUNITY GARDEN!

Water
Park!
90012

more lights
at the back

200

Bring back the pony rides

Bring back the ponies!
90005
Est. 1991

Archie game
91714

Something
Fun & Fun for
Animals too!
90005
make a petting zoo

Bring back the pony rides
91303
Ariel
adorably ugly
to pens!
Because ponies are
adorable and it was
worth it to go!
-90021
yay!

Bring the ponies
back!
91306



Reimagining the Pony Ride Site



Learn more and join our mailing list at:
Obtenga más información y únase a
nuestra lista de correo en:
www.laparks.org/griffithpark/pony-rides

Your drawing may
be displayed on our
website!

Tu dibujo puede ser
que se muestra
en el sitio web del
proyecto.

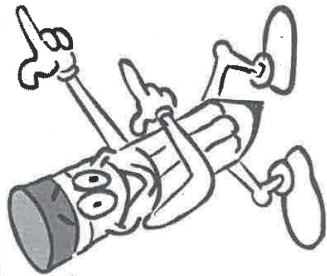

We are re-designing a part of Griffith Park for the future!
¡Estamos rediseñando una parte de Griffith Park para el futuro!

Use your imagination! Draw a picture of what you would like to see in the park.
¡Use su imaginación! Haz un dibujo de lo que te gustaría ver en el parque.



Reimagining the Pony Ride Site



Learn more and join our mailing list at:
Obtenga más información y únase a
nuestra lista de correo en:
www.laparks.org/griffithpark/pony-rides

Your drawing may
be displayed on our
website!

Tu dibujo puede ser
que se muestra
en el sitio web del
proyecto.

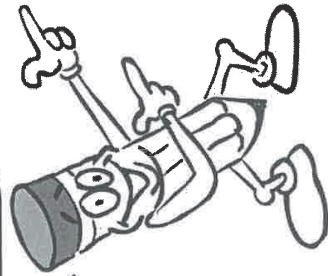

We are re-designing a part of Griffith Park for the future!
¡Estamos rediseñando una parte de Griffith Park para el futuro!

Use your imagination! Draw a picture of what you would like to see in the park.
¡Use su imaginación! Haz un dibujo de lo que te gustaría ver en el parque.

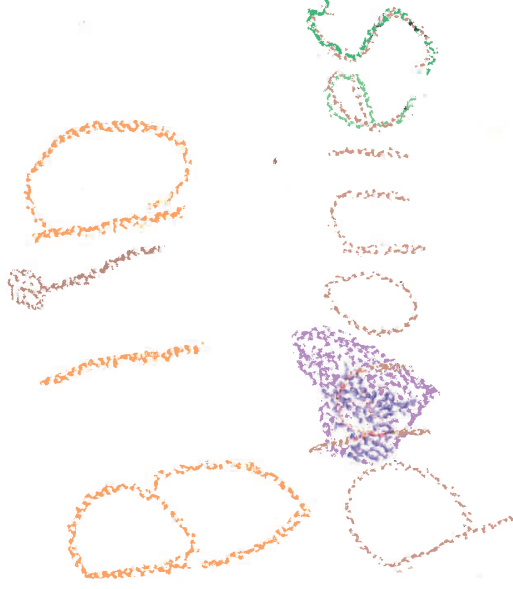

Reimagining the Pony Ride Site



Learn more and join our mailing list at:
Obtenga más información y únase a
nuestra lista de correo en:
www.laparks.org/griffithpark/pony-rides

Your drawing may
be displayed on our
website!

Tu dibujo puede ser
que se muestra
en el sitio web del
proyecto.

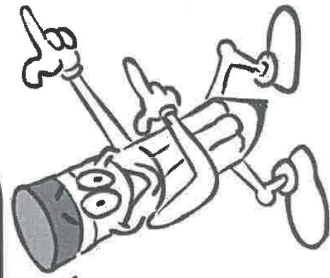

We are re-designing a part of Griffith Park for the future!
¡Estamos rediseñando una parte de Griffith Park para el futuro!

Use your imagination! Draw a picture of what you would like to see in the park.
¡Use su imaginación! Haz un dibujo de lo que te gustaría ver en el parque.

Griffith



Reimagining the Pony Ride Site



Learn more and join our mailing list at:
Obtenga más información y únase a
nuestra lista de correo en:
www.laparks.org/griffithpark/pony-rides

Your drawing may
be displayed on our
website!

Tu dibujo puede ser
que se muestra
en el sitio web del
proyecto.

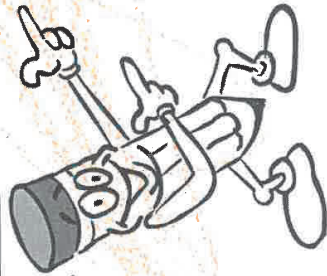

We are re-designing a part of Griffith Park for the future!
¡Estamos rediseñando una parte de Griffith Park para el futuro!

Use your imagination! Draw a picture of what you would like to see in the park.
¡Use su imaginación! Haz un dibujo de lo que te gustaría ver en el parque.

2024/2023



Reimagining the Pony Ride Site



Learn more and join our mailing list at:
Obtenga más información y únase a
nuestra lista de correo en:
www.laparks.org/griffithpark/pony-rides

Your drawing may
be displayed on our
website!

Tu dibujo puede ser
que se muestra
en el sitio web del
proyecto.

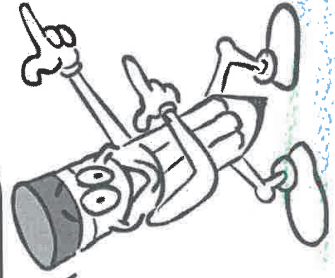

We are re-designing a part of Griffith Park for the future! ¡Estamos rediseñando una parte de Griffith Park para el futuro!

Use your imagination! Draw a picture of what you would like to see in the park.
¡Use su imaginación! Haz un dibujo de lo que te gustaría ver en el parque.

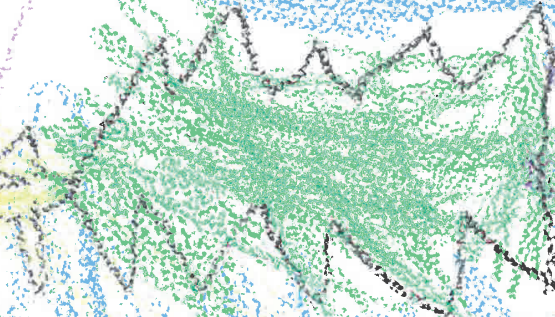

Reimagining the Pony Ride Site



Learn more and join our mailing list at:
Obtenga más información y únase a
nuestra lista de correo en:
www.laparks.org/griffithpark/pony-rides

Your drawing may
be displayed on our
website!

Tu dibujo puede ser
que se muestra
en el sitio web del
proyecto.

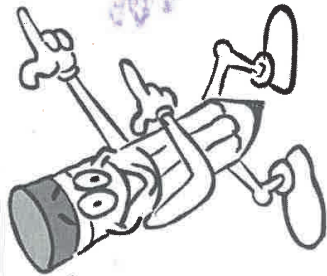

We are re-designing a part of Griffith Park for the future!
¡Estamos rediseñando una parte de Griffith Park para el futuro!

Use your imagination! Draw a picture of what you would like to see in the park.
¡Use su imaginación! Haz un dibujo de lo que te gustaría ver en el parque.



Reimagining the Pony Ride Site



Learn more and join our mailing list at:
Obtenga más información y únase a
nuestra lista de correo en:
www.laparks.org/griffithpark/pony-rides

Your drawing may
be displayed on our
website!

Tu dibujo puede ser
que se muestra
en el sitio web del
proyecto.

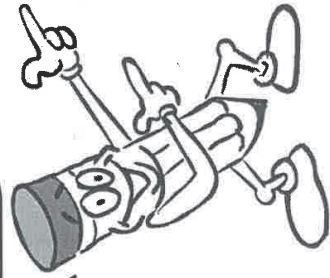

We are re-designing a part of Griffith Park for the future! ¡Estamos rediseñando una parte de Griffith Park para el futuro!

Use your imagination! Draw a picture of what you would like to see in the park.
¡Use su imaginación! Haz un dibujo de lo que te gustaría ver en el parque.



Reimagining the Pony Ride Site



Learn more and join our mailing list at:
Obtenga más información y únase a
nuestra lista de correo en:
www.laparks.org/griffithpark/pony-rides

Your drawing may
be displayed on our
website!

Tu dibujo puede ser
que se muestra
en el sitio web del
proyecto.

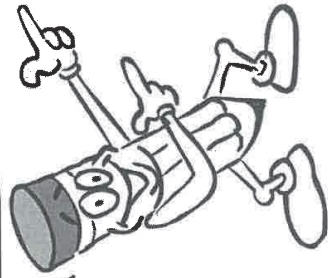

We are re-designing a part of Griffith Park for the future!
¡Estamos rediseñando una parte de Griffith Park para el futuro!

Use your imagination! Draw a picture of what you would like to see in the park.
¡Use su imaginación! Haz un dibujo de lo que te gustaría ver en el parque.

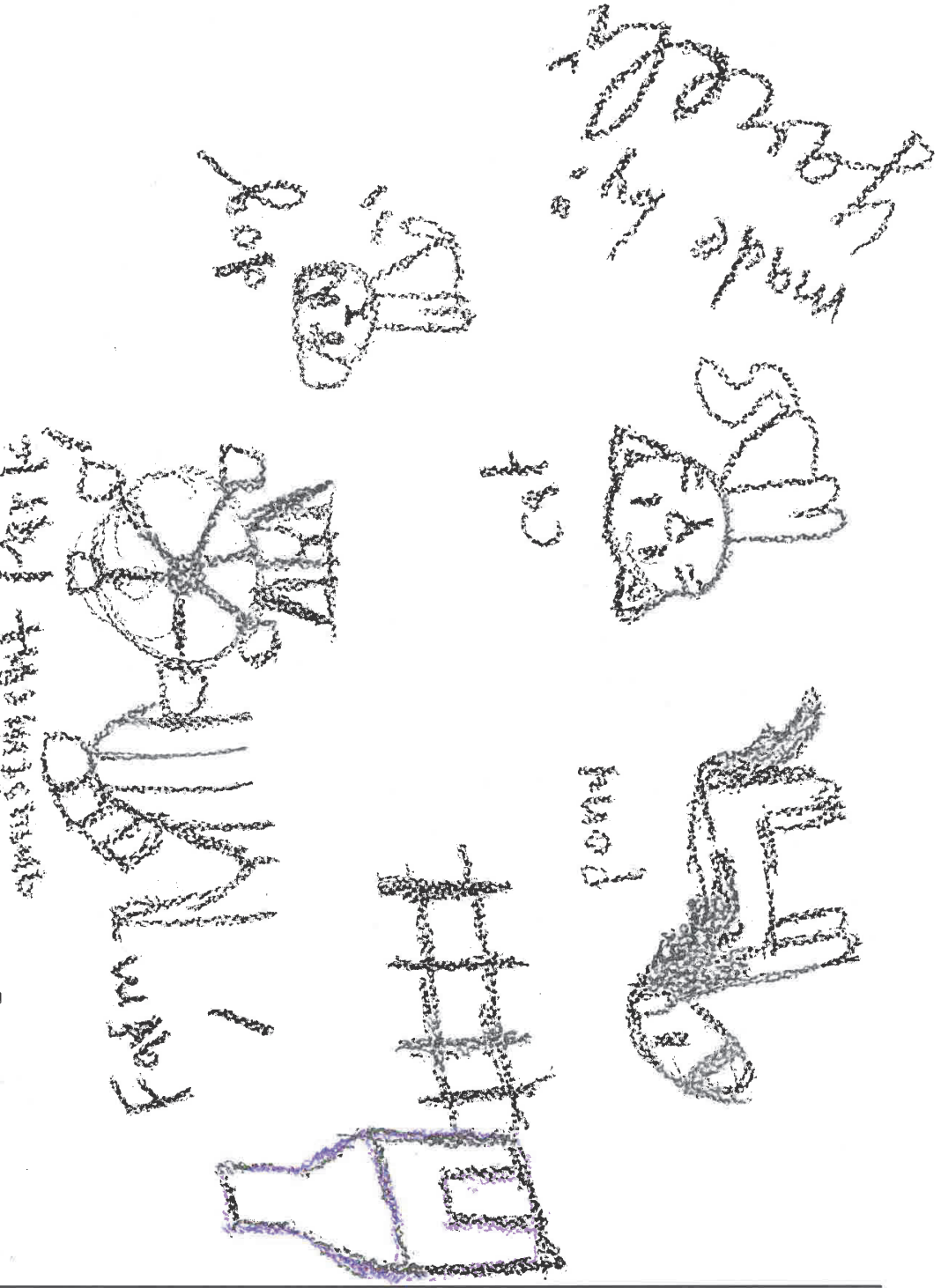

Reimagining the Pony Ride Site



Learn more and join our mailing list at:
Obtenga más información y únase a
nuestra lista de correo en:
www.laparks.org/griffithpark/pony-rides

Your drawing may
be displayed on our
website!

Tu dibujo puede ser
que se muestra
en el sitio web del
proyecto.



We are re-designing a part of Griffith Park for the future!
¡Estamos rediseñando una parte de Griffith Park para el futuro!

Use your imagination! Draw a picture of what you would like to see in the park.
¡Use su imaginación! Haz un dibujo de lo que te gustaría ver en el parque.

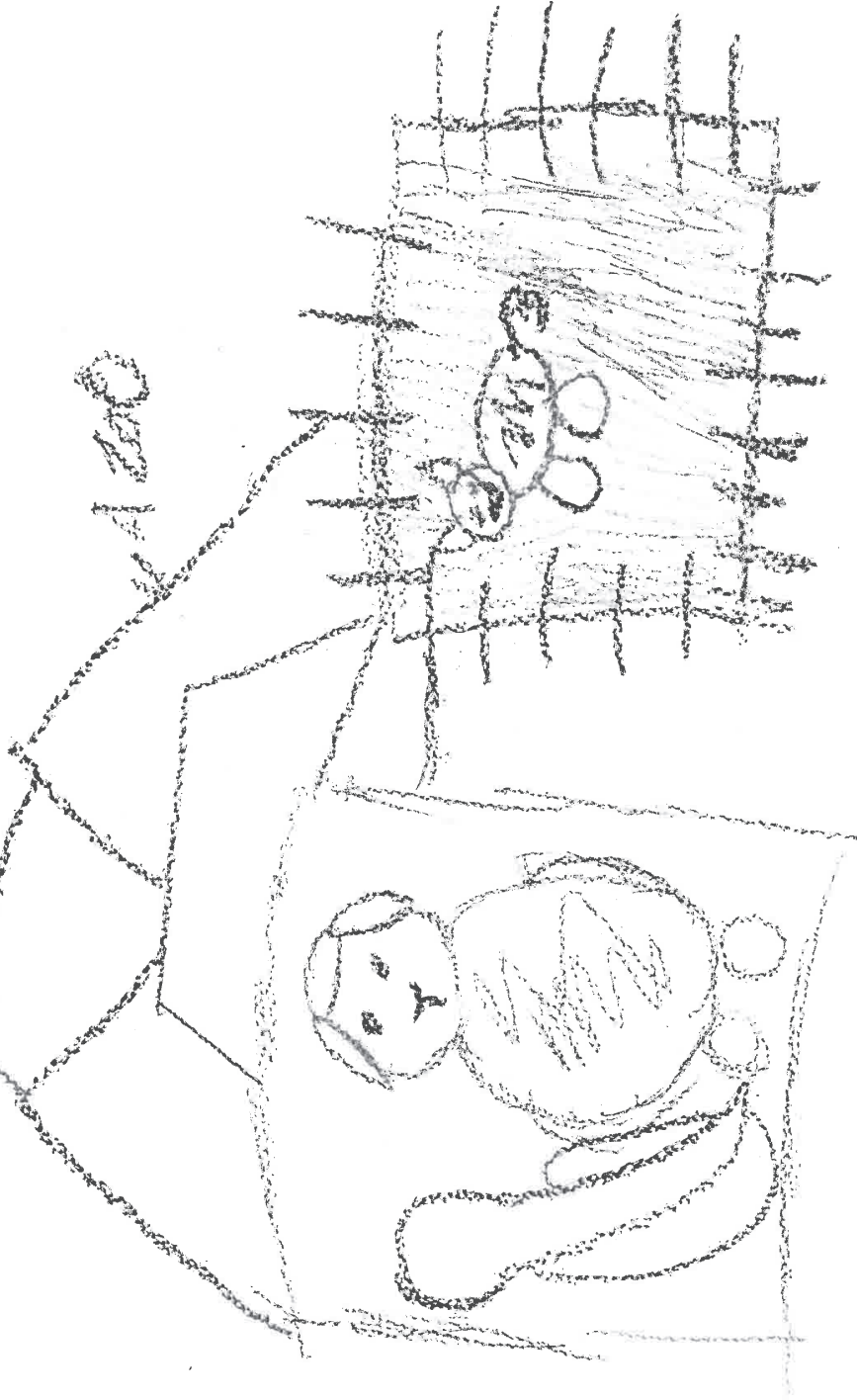

Reimagining the Pony Ride Site



Learn more and join our mailing list at:
Obtenga más información y únase a
nuestra lista de correo en:
www.laparks.org/griffithpark/pony-rides

Your drawing may
be displayed on our
website!

Tu dibujo puede ser
que se muestra
en el sitio web del
proyecto.

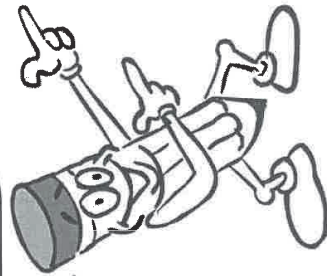

We are re-designing a part of Griffith Park for the future!
¡Estamos rediseñando una parte de Griffith Park para el futuro!

Use your imagination! Draw a picture of what you would like to see in the park.
¡Use su imaginación! Haz un dibujo de lo que te gustaría ver en el parque.

Mick Anthony Reynolds III



Reimagining the Pony Ride Site



Learn more and join our mailing list at:
Obtenga más información y únase a
nuestra lista de correo en:
www.laparks.org/griffithpark/pony-rides

Your drawing may
be displayed on our
website!

Tu dibujo puede ser
que se muestra
en el sitio web del
proyecto.

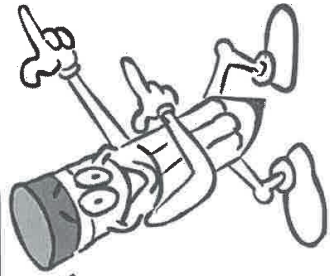

We are re-designing a part of Griffith Park for the future!
¡Estamos rediseñando una parte de Griffith Park para el futuro!

Use your imagination! Draw a picture of what you would like to see in the park.
¡Use su imaginación! Haz un dibujo de lo que te gustaría ver en el parque.

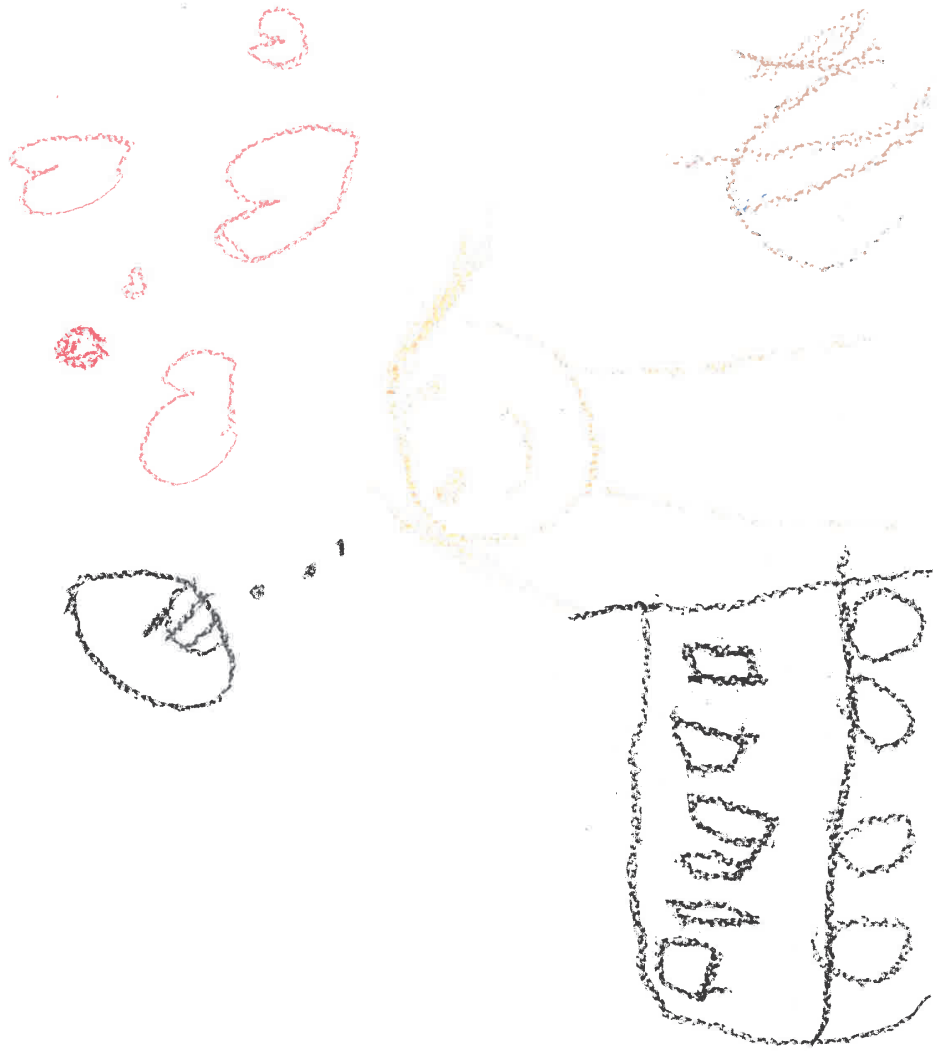

Reimagining the Pony Ride Site



Learn more and join our mailing list at:
Obtenga más información y únase a
nuestra lista de correo en:
www.laparks.org/griffithpark/pony-rides

Your drawing may
be displayed on our
website!

Tu dibujo puede ser
que se muestra
en el sitio web del
proyecto.

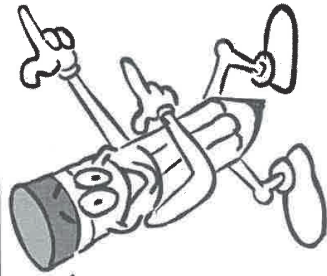

We are re-designing a part of Griffith Park for the future!
¡Estamos rediseñando una parte de Griffith Park para el futuro!

Use your imagination! Draw a picture of what you would like to see in the park.
¡Use su imaginación! Haz un dibujo de lo que te gustaría ver en el parque.

Art de

Landon



Reimagining the Pony Ride Site



Learn more and join our mailing list at:
Obtenga más información y únase a
nuestra lista de correo en:
www.laparks.org/griffithpark/pony-rides

Your drawing may
be displayed on our
website!

Tu dibujo puede ser
que se muestra
en el sitio web del
proyecto.

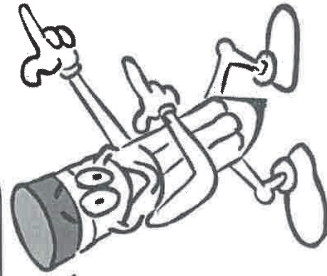

We are re-designing a part of Griffith Park for the future!
¡Estamos rediseñando una parte de Griffith Park para el futuro!

Use your imagination! Draw a picture of what you would like to see in the park.
¡Use su imaginación! Haz un dibujo de lo que te gustaría ver en el parque.

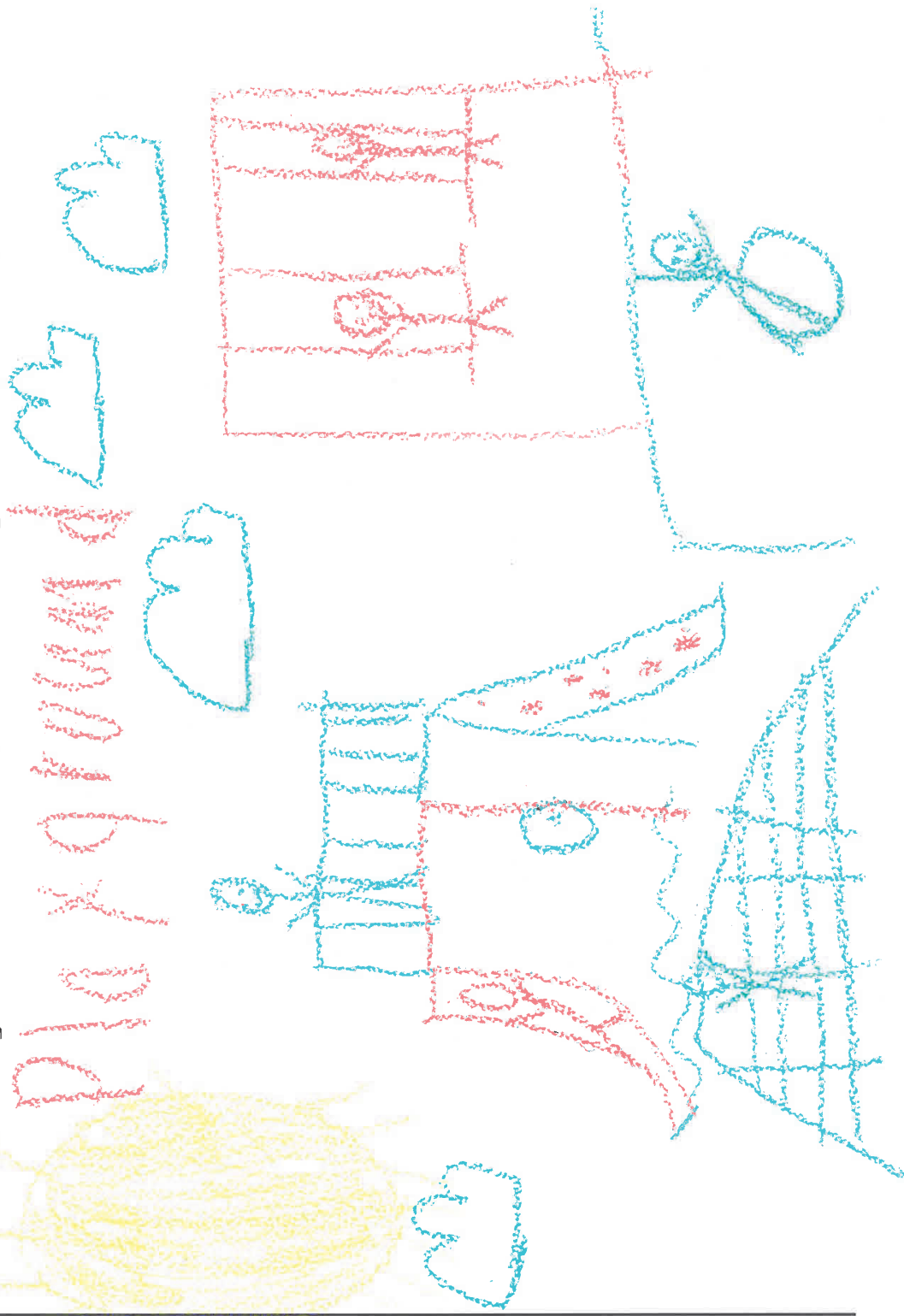

Reimagining the Pony Ride Site



Learn more and join our mailing list at:
Obtenga más información y únase a
nuestra lista de correo en:
www.laparks.org/griffithpark/pony-rides

Your drawing may
be displayed on our
website!

Tu dibujo puede ser
que se muestra
en el sitio web del
proyecto.

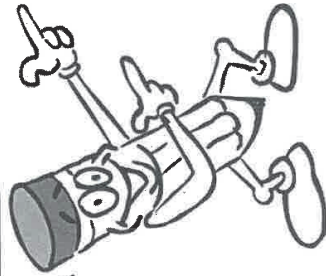

We are re-designing a part of Griffith Park for the future! ¡Estamos rediseñando una parte de Griffith Park para el futuro!

Use your imagination! Draw a picture of what you would like to see in the park.
¡Use su imaginación! Haz un dibujo de lo que te gustaría ver en el parque.

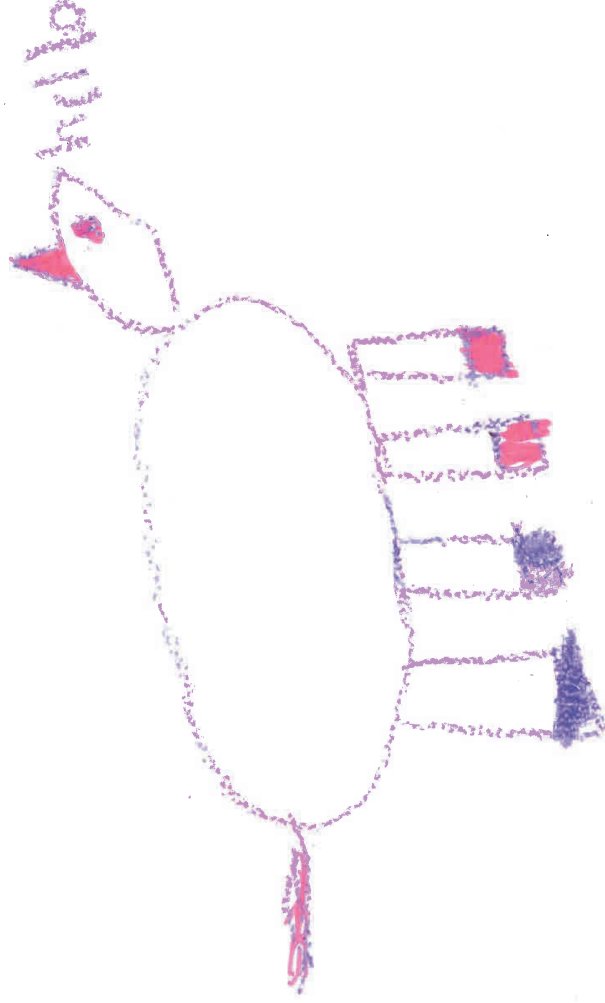

¡Wow!

Reimagining the Pony Ride Site



Learn more and join our mailing list at:
Obtenga más información y únase a
nuestra lista de correo en:
www.laparks.org/griffithpark/pony-rides

Your drawing may
be displayed on our
website!

Tu dibujo puede ser
que se muestra
en el sitio web del
proyecto.

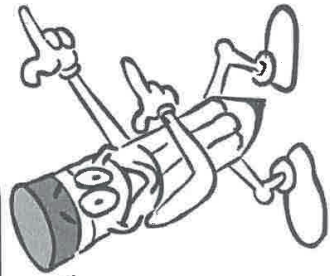

We are re-designing a part of Griffith Park for the future!
¡Estamos rediseñando una parte de Griffith Park para el futuro!

Use your imagination! Draw a picture of what you would like to see in the park.
¡Use su imaginación! Haz un dibujo de lo que te gustaría ver en el parque.

pony



Reimagining the Pony Ride Site



Learn more and join our mailing list at:
Obtenga más información y únase a
nuestra lista de correo en:
www.laparks.org/griffithpark/pony-rides

Your drawing may
be displayed on our
website!

Tu dibujo puede ser
que se muestra
en el sitio web del
proyecto.

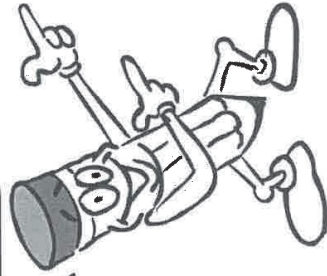

We are re-designing a part of Griffith Park for the future!
¡Estamos rediseñando una parte de Griffith Park para el futuro!

Use your imagination! Draw a picture of what you would like to see in the park.
¡Use su imaginación! Haz un dibujo de lo que te gustaría ver en el parque.

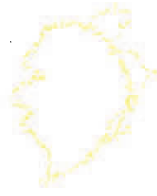
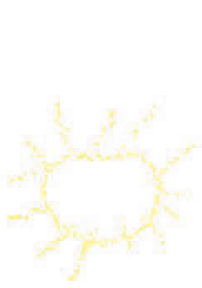

Reimagining the Pony Ride Site



Learn more and join our mailing list at:
Obtenga más información y únase a
nuestra lista de correo en:
www.laparks.org/griffithpark/pony-rides

Your drawing may
be displayed on our
website!

Tu dibujo puede ser
que se muestra
en el sitio web del
proyecto.

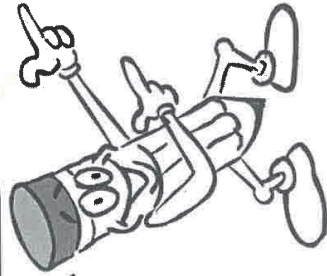

We are re-designing a part of Griffith Park for the future!
¡Estamos rediseñando una parte de Griffith Park para el futuro!

Use your imagination! Draw a picture of what you would like to see in the park.
¡Use su imaginación! Haz un dibujo de lo que te gustaría ver en el parque.



JACKSON

Reimagining the Pony Ride Site



Learn more and join our mailing list at:
Obtenga más información y únase a
nuestra lista de correo en:
www.laparks.org/griffithpark/pony-rides

Your drawing may
be displayed on our
website!

Tu dibujo puede ser
que se muestra
en el sitio web del
proyecto.

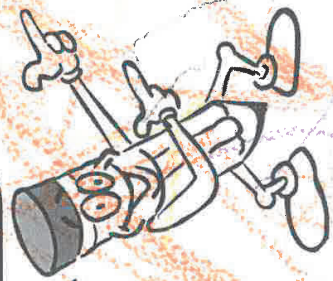

We are re-designing a part of Griffith Park for the future!
¡Estamos rediseñando una parte de Griffith Park para el futuro!

Use your imagination! Draw a picture of what you would like to see in the park.
¡Use su imaginación! Haz un dibujo de lo que te gustaría ver en el parque.

iam



Reimagining the Pony Ride Site



Learn more and join our mailing list at:
Obtenga más información y únase a
nuestra lista de correo en:
www.laparks.org/griffithpark/pony-rides

Your drawing may
be displayed on our
website!

Tu dibujo puede ser
que se muestra
en el sitio web del
proyecto.

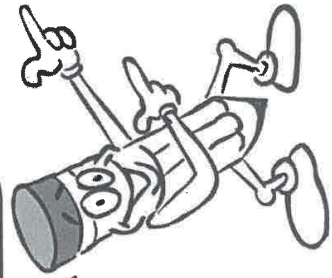

We are re-designing a part of Griffith Park for the future! ¡Estamos rediseñando una parte de Griffith Park para el futuro!

Use your imagination! Draw a picture of what you would like to see in the park.
¡Use su imaginación! Haz un dibujo de lo que te gustaría ver en el parque.

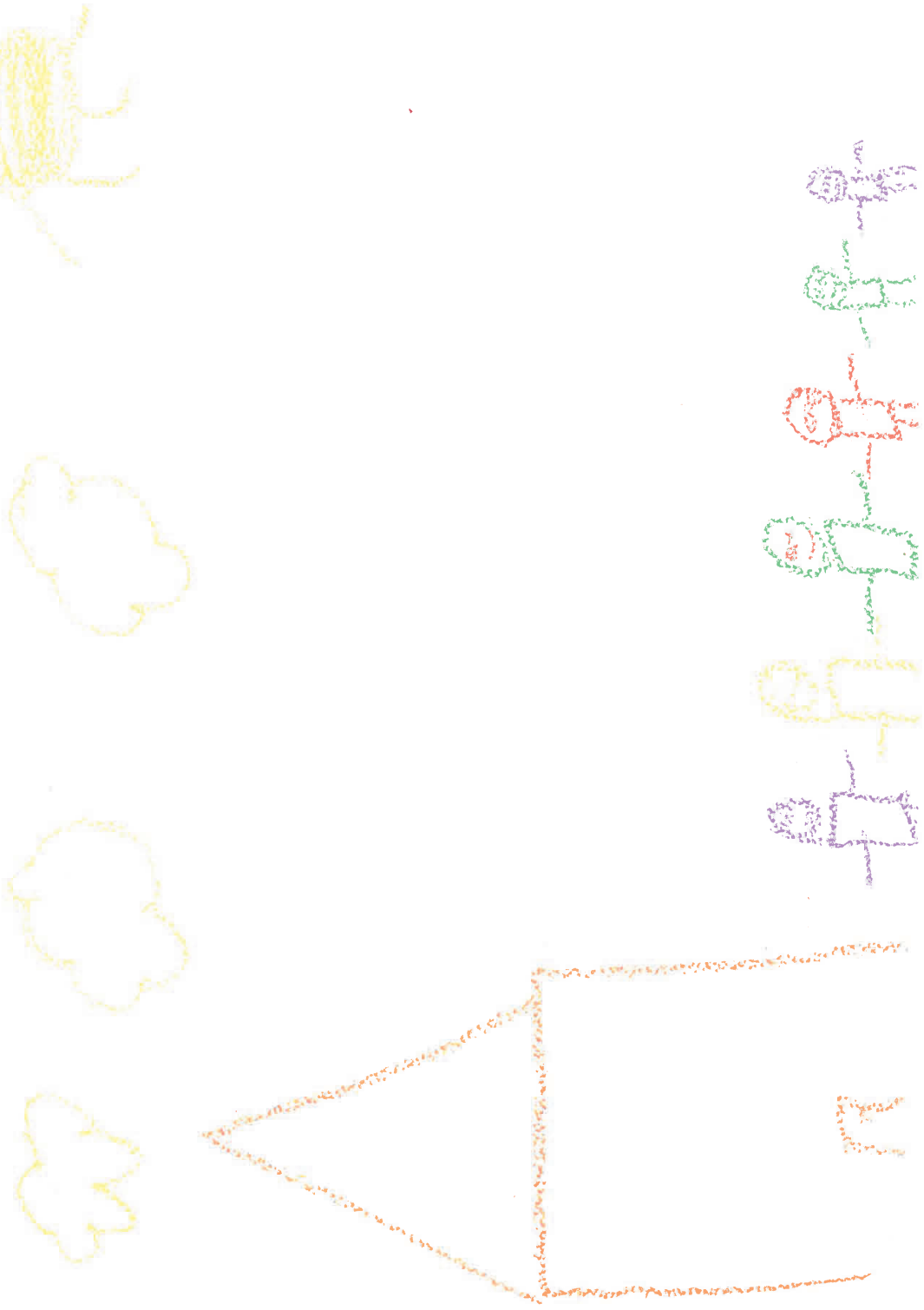

Reimagining the Pony Ride Site



Learn more and join our mailing list at:
Obtenga más información y únase a
nuestra lista de correo en:
www.laparks.org/griffithpark/pony-rides

Your drawing may
be displayed on our
website!

Tu dibujo puede ser
que se muestra
en el sitio web del
proyecto.

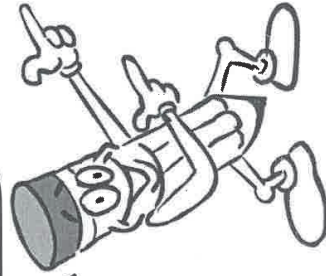

We are re-designing a part of Griffith Park for the future!
¡Estamos rediseñando una parte de Griffith Park para el futuro!

Use your imagination! Draw a picture of what you would like to see in the park.
¡Use su imaginación! Haz un dibujo de lo que te gustaría ver en el parque.

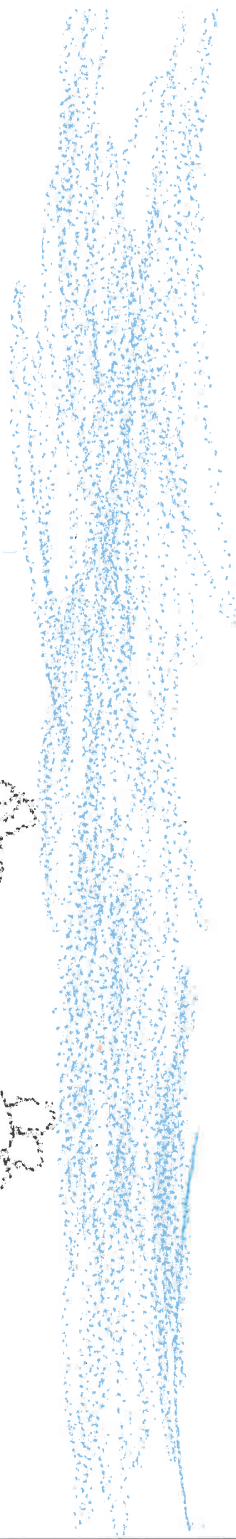
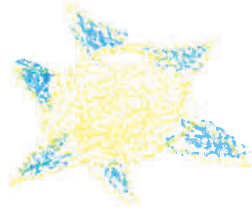

Reimagining the Pony Ride Site



Learn more and join our mailing list at:
Obtenga más información y únase a
nuestra lista de correo en:
www.laparks.org/griffithpark/pony-rides

Your drawing may
be displayed on our
website!

Tu dibujo puede ser
que se muestra
en el sitio web del
proyecto.

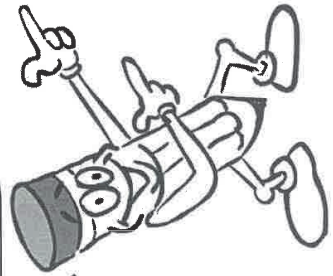

We are re-designing a part of Griffith Park for the future! ¡Estamos rediseñando una parte de Griffith Park para el futuro!

Use your imagination! Draw a picture of what you would like to see in the park.
¡Use su imaginación! Haz un dibujo de lo que te gustaría ver en el parque.

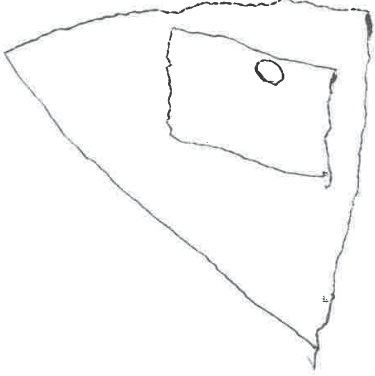

Reimagining the Pony Ride Site



Learn more and join our mailing list at:
Obtenga más información y únase a
nuestra lista de correo en:
www.laparks.org/griffithpark/pony-rides

Your drawing may
be displayed on our
website!

Tu dibujo puede ser
que se muestra
en el sitio web del
proyecto.

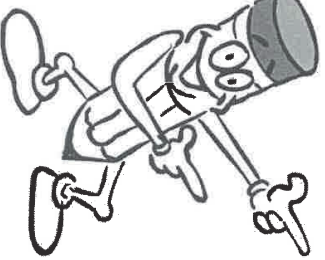

**We are re-designing a part of Griffith Park for the future!
¡Estamos rediseñando una parte de Griffith Park para el futuro!**

Use your imagination! Draw a picture of what you would like to see in the park.
¡Use su imaginación! Haz un dibujo de lo que te gustaría ver en el parque.

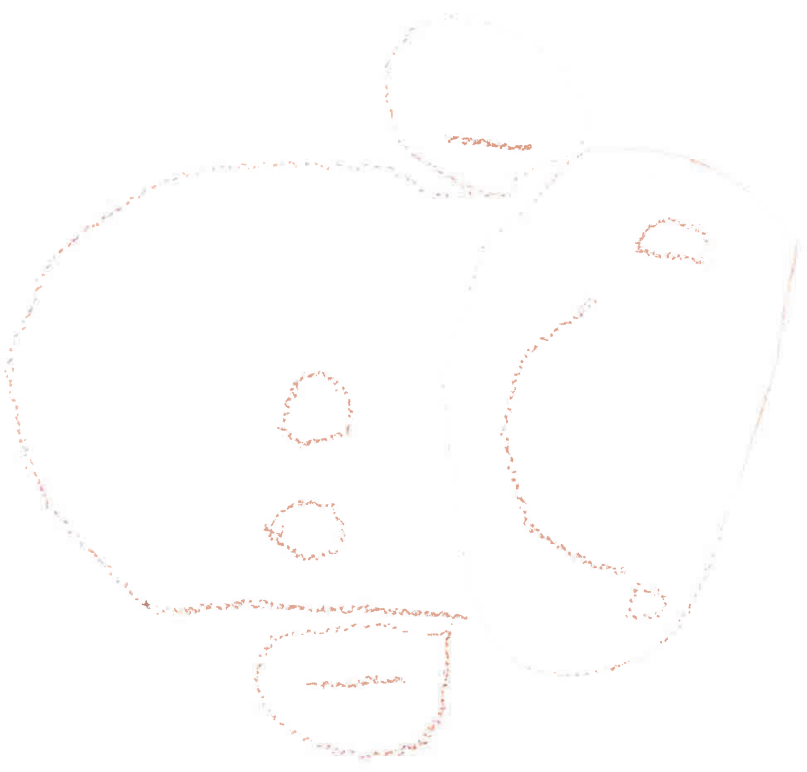

Año 2000

Reimagining the Pony Ride Site



Learn more and join our mailing list at:
Obtenga más información y únase a
nuestra lista de correo en:
www.laparks.org/griffithpark/pony-rides

Your drawing may
be displayed on our
website!

Tu dibujo puede ser
que se muestra
en el sitio web del
proyecto.

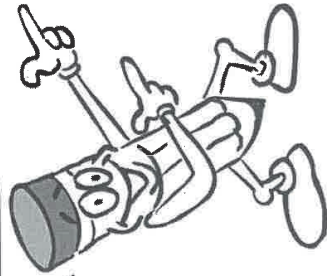

We are re-designing a part of Griffith Park for the future!
¡Estamos rediseñando una parte de Griffith Park para el futuro!

Use your imagination! Draw a picture of what you would like to see in the park.
¡Use su imaginación! Haz un dibujo de lo que te gustaría ver en el parque.

A rocket you can go in



Reimagining the Pony Ride Site



Learn more and join our mailing list at:
Obtenga más información y únase a
nuestra lista de correo en:
www.laparks.org/griffithpark/pony-rides

Your drawing may
be displayed on our
website!

Tu dibujo puede ser
que se muestra
en el sitio web del
proyecto.

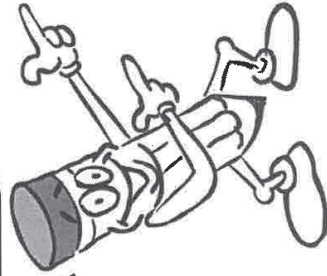

We are re-designing a part of Griffith Park for the future!
¡Estamos rediseñando una parte de Griffith Park para el futuro!

Use your imagination! Draw a picture of what you would like to see in the park.
¡Use su imaginación! Haz un dibujo de lo que te gustaría ver en el parque.

Zip Line

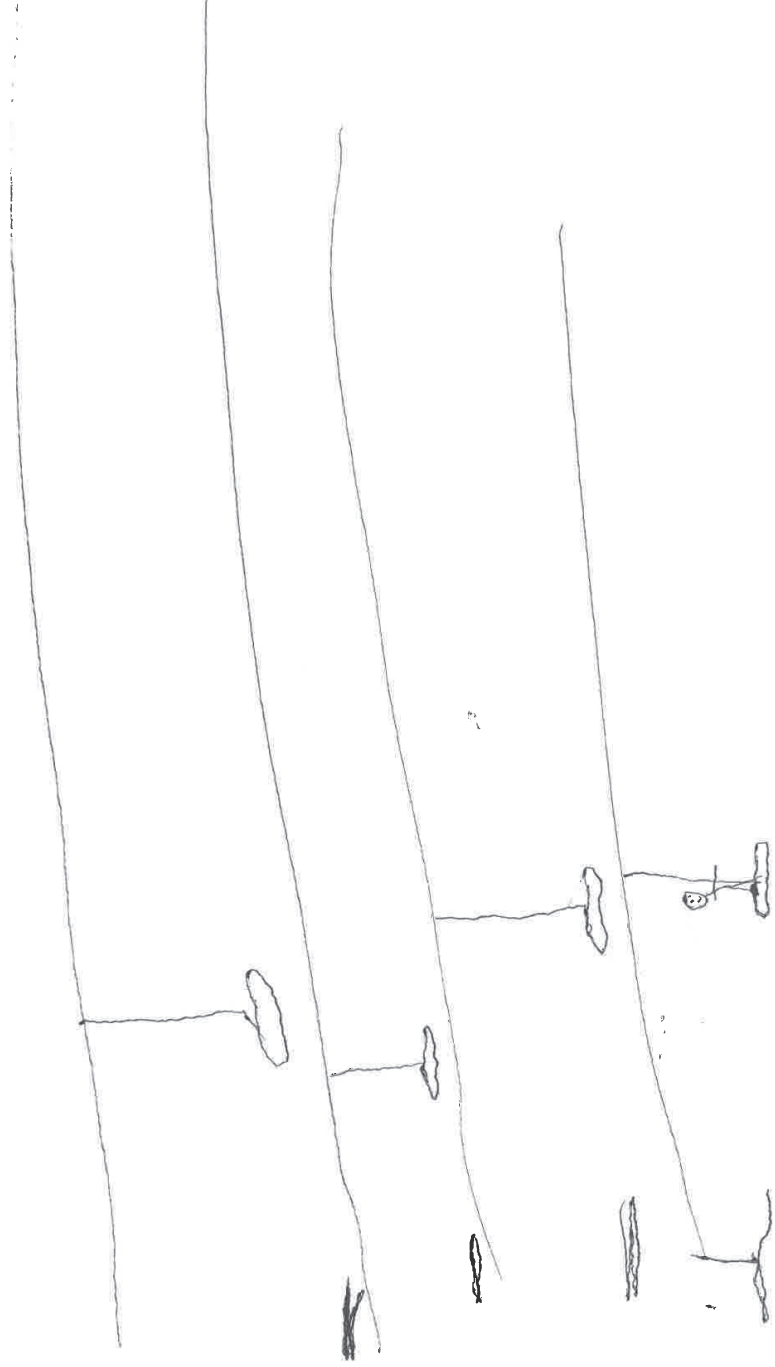

Reimagining the Pony Ride Site



Learn more and join our mailing list at:
Obtenga más información y únase a
nuestra lista de correo en:
www.laparks.org/griffithpark/pony-rides

Your drawing may
be displayed on our
website!

Tu dibujo puede ser
que se muestra
en el sitio web del
proyecto.

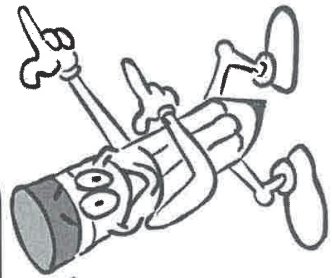

We are re-designing a part of Griffith Park for the future! ¡Estamos rediseñando una parte de Griffith Park para el futuro!

Use your imagination! Draw a picture of what you would like to see in the park.
¡Use su imaginación! Haz un dibujo de lo que te gustaría ver en el parque.

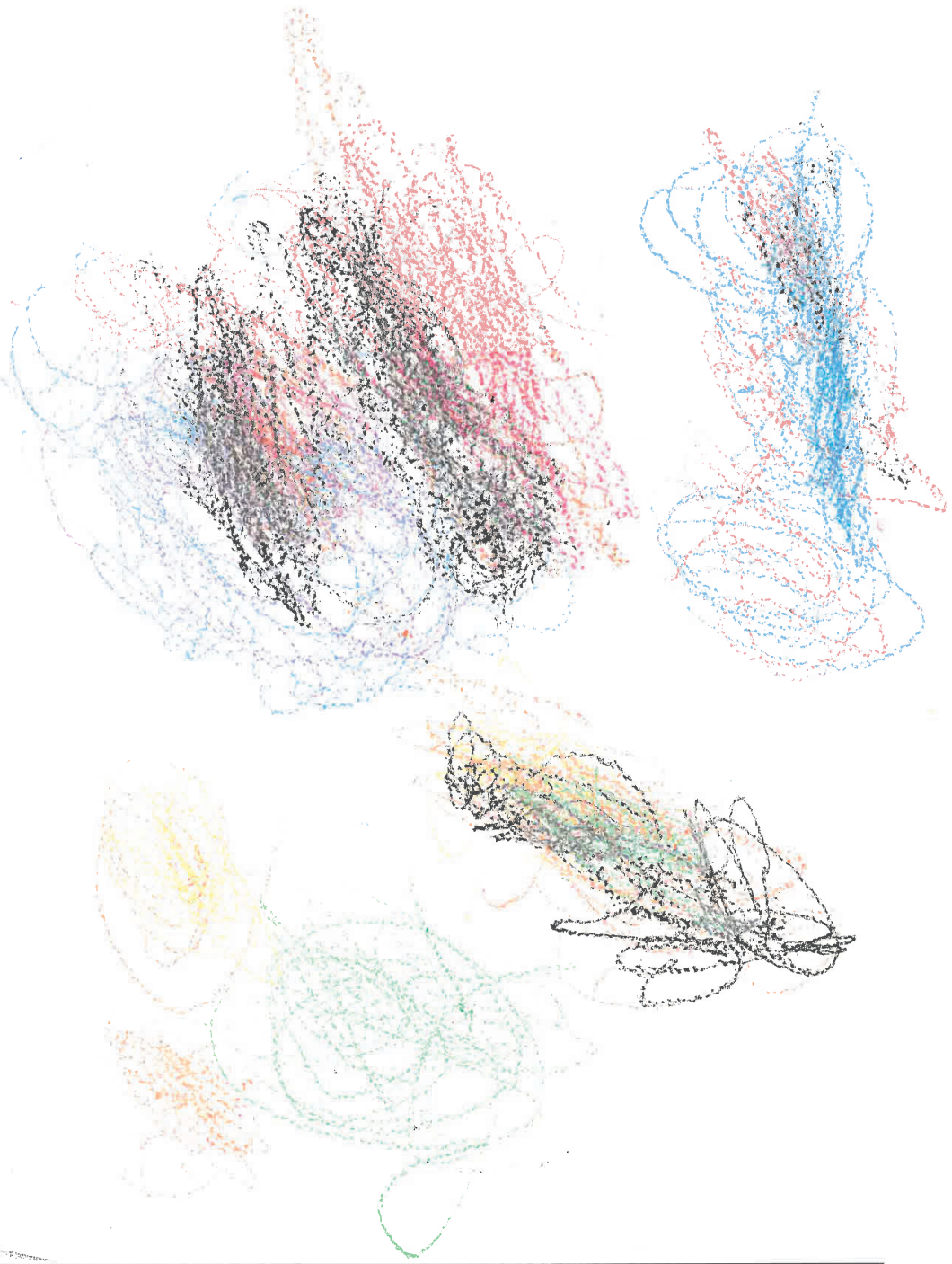

Reimagining the Pony Ride Site



Learn more and join our mailing list at:
Obtenga más información y únase a
nuestra lista de correo en:
www.laparks.org/griffithpark/pony-rides

Your drawing may
be displayed on our
website!

Tu dibujo puede ser
que se muestra
en el sitio web del
proyecto.

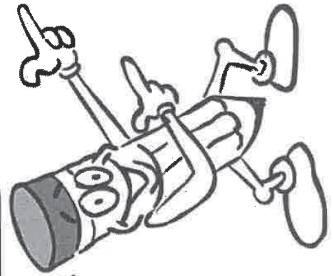

We are re-designing a part of Griffith Park for the future!
¡Estamos rediseñando una parte de Griffith Park para el futuro!

Use your imagination! Draw a picture of what you would like to see in the park.
¡Use su imaginación! Haz un dibujo de lo que te gustaría ver en el parque.

IDEAS

-Keep Pony Rides

-Farm animal

Reimagining the Pony Ride Site



Learn more and join our mailing list at:
Obtenga más información y únase a
nuestra lista de correo en:
www.laparks.org/griffithpark/pony-rides

Your drawing may
be displayed on our
website!

Tu dibujo puede ser
que se muestra
en el sitio web del
proyecto.

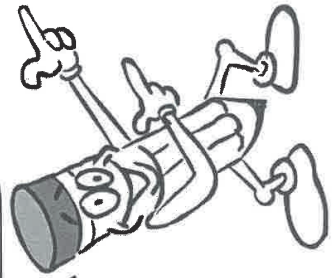

We are re-designing a part of Griffith Park for the future! ¡Estamos rediseñando una parte de Griffith Park para el futuro!

Use your imagination! Draw a picture of what you would like to see in the park.
¡Use su imaginación! Haz un dibujo de lo que te gustaría ver en el parque.

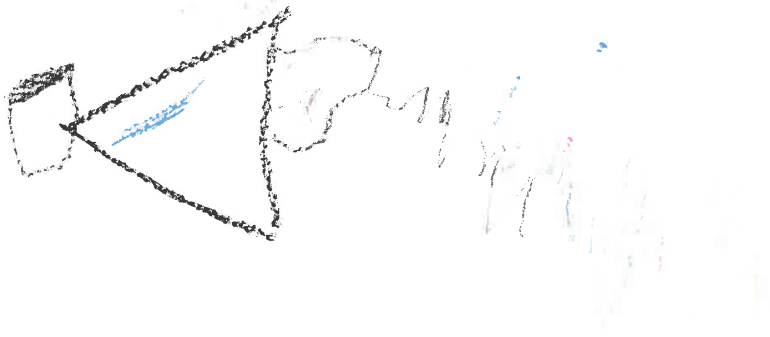

Reimagining the Pony Ride Site



Learn more and join our mailing list at:
Obtenga más información y únase a
nuestra lista de correo en:
www.laparks.org/griffithpark/pony-rides

Your drawing may
be displayed on our
website!

Tu dibujo puede ser
que se muestra
en el sitio web del
proyecto.

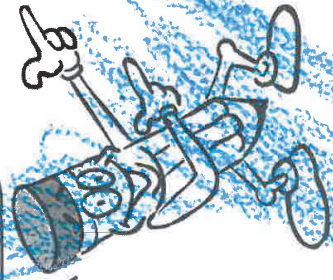

We are re-designing a part of Griffith Park for the future! ¡Estamos rediseñando una parte de Griffith Park para el futuro!

Use your imagination! Draw a picture of what you would like to see in the park.
¡Use su imaginación! Haz un dibujo de lo que te gustaría ver en el parque.

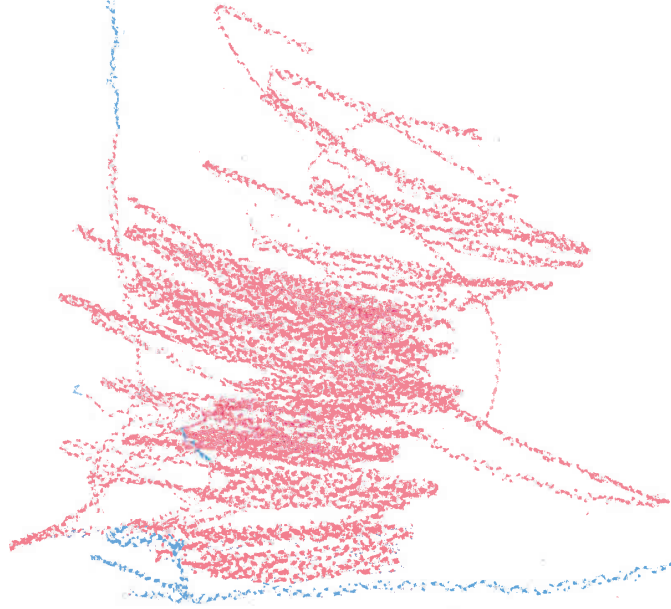

Reimagining the Pony Ride Site



Learn more and join our mailing list at:
Obtenga más información y únase a
nuestra lista de correo en:
www.laparks.org/griffithpark/pony-rides

Your drawing may
be displayed on our
website!

Tu dibujo puede ser
que se muestra
en el sitio web del
proyecto.

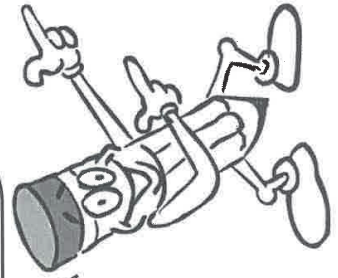

We are re-designing a part of Griffith Park for the future! ¡Estamos rediseñando una parte de Griffith Park para el futuro!

Use your imagination! Draw a picture of what you would like to see in the park.
¡Use su imaginación! Haz un dibujo de lo que te gustaría ver en el parque.



Reimagining the Pony Ride Site



Learn more and join our mailing list at:
Obtenga más información y únase a
nuestra lista de correo en:
www.laparks.org/griffithpark/pony-rides

Your drawing may
be displayed on our
website!

Tu dibujo puede ser
que se muestra
en el sitio web del
proyecto.



We are re-designing a part of Griffith Park for the future! ¡Estamos rediseñando una parte de Griffith Park para el futuro!

Use your imagination! Draw a picture of what you would like to see in the park.
¡Use su imaginación! Haz un dibujo de lo que te gustaría ver en el parque.



Reimagining the Pony Ride Site



Learn more and join our mailing list at:
Obtenga más información y únase a
nuestra lista de correo en:
www.laparks.org/griffithpark/pony-rides

Your drawing may
be displayed on our
website!

Tu dibujo puede ser
que se muestra
en el sitio web del
proyecto.

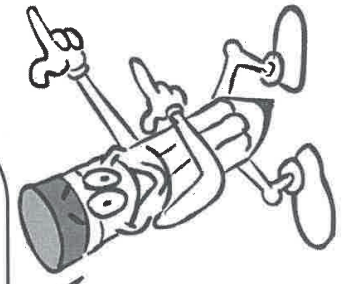

We are re-designing a part of Griffith Park for the future! ¡Estamos rediseñando una parte de Griffith Park para el futuro!

Use your imagination! Draw a picture of what you would like to see in the park.
¡Use su imaginación! Haz un dibujo de lo que te gustaría ver en el parque.

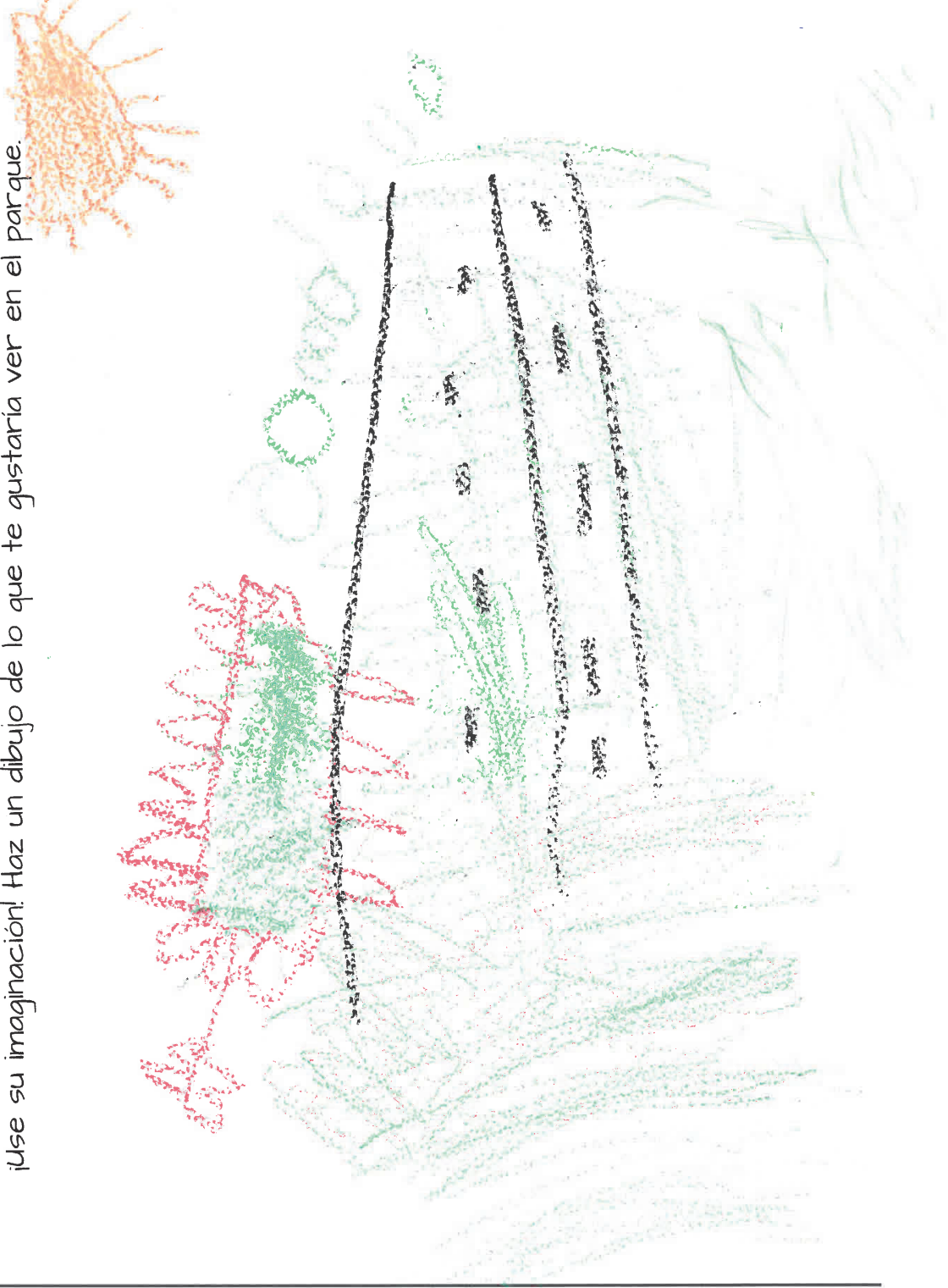

Reimagining the Pony Ride Site



Learn more and join our mailing list at:
Obtenga más información y únase a
nuestra lista de correo en:
www.laparks.org/griffithpark/pony-rides

Your drawing may
be displayed on our
website!

Tu dibujo puede ser
que se muestra
en el sitio web del
proyecto.

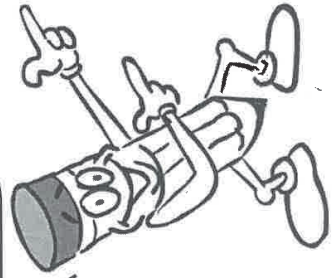

We are re-designing a part of Griffith Park for the future! ¡Estamos rediseñando una parte de Griffith Park para el futuro!

Use your imagination! Draw a picture of what you would like to see in the park.
¡Use su imaginación! Haz un dibujo de lo que te gustaría ver en el parque.

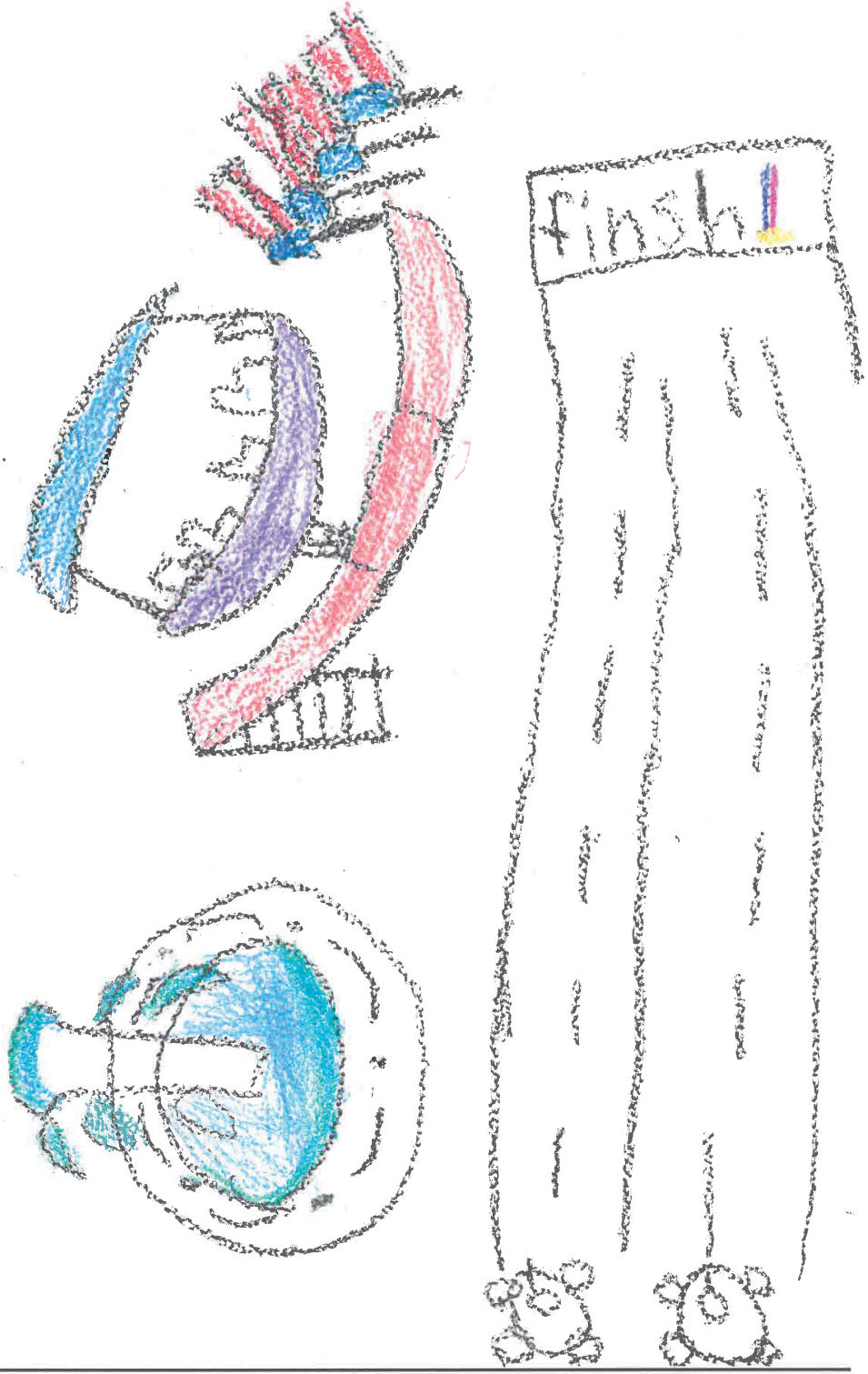

Appendix J.

Opinion Poll (Statistically Valid) Results





City of Los Angeles Griffith Park Study

January 28-February 4, 2024



OPINION
RESEARCH
& STRATEGY

Survey Methodology

Dates	January 28-February 4, 2024
Survey Type	Dual-mode Resident Survey
Research Population	City of Los Angeles Residents Ages 18+
Total Interviews	564
Margin of Sampling Error	(Full Sample) $\pm 4.4\%$ at the 95% Confidence Level (Half Sample) $\pm 6.3\%$ at the 95% Confidence Level
Contact Methods	 Telephone Calls  Email Invitations  Text Invitations
Data Collection Modes	 Telephone Interviews  Online Interviews
Languages	English and Spanish (Online and on Telephone)

(Note: Not All Results Will Sum to 100% Due to Rounding)



Awareness of Griffith Park and Visitor Behavior

Nearly 9 in 10 respondents said they have been to Griffith Park.

Have you personally ever been to Griffith Park?

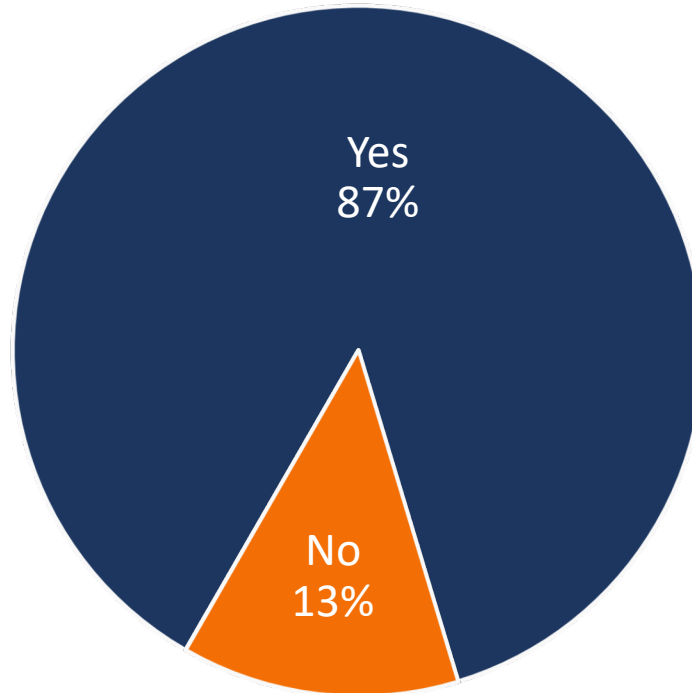

Nearly 9 in 10 respondents said they have been to Griffith Park; another 11% when informed of park attractions.

Have you personally ever been to Griffith Park?

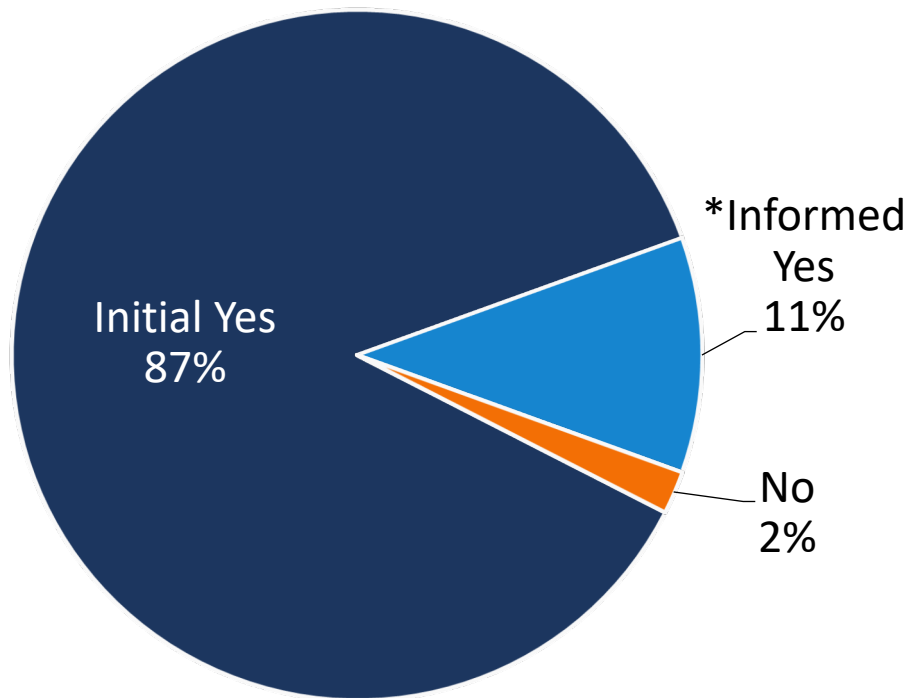

Two out of 3 respondents feel they are at least “somewhat” familiar with Griffith Park.

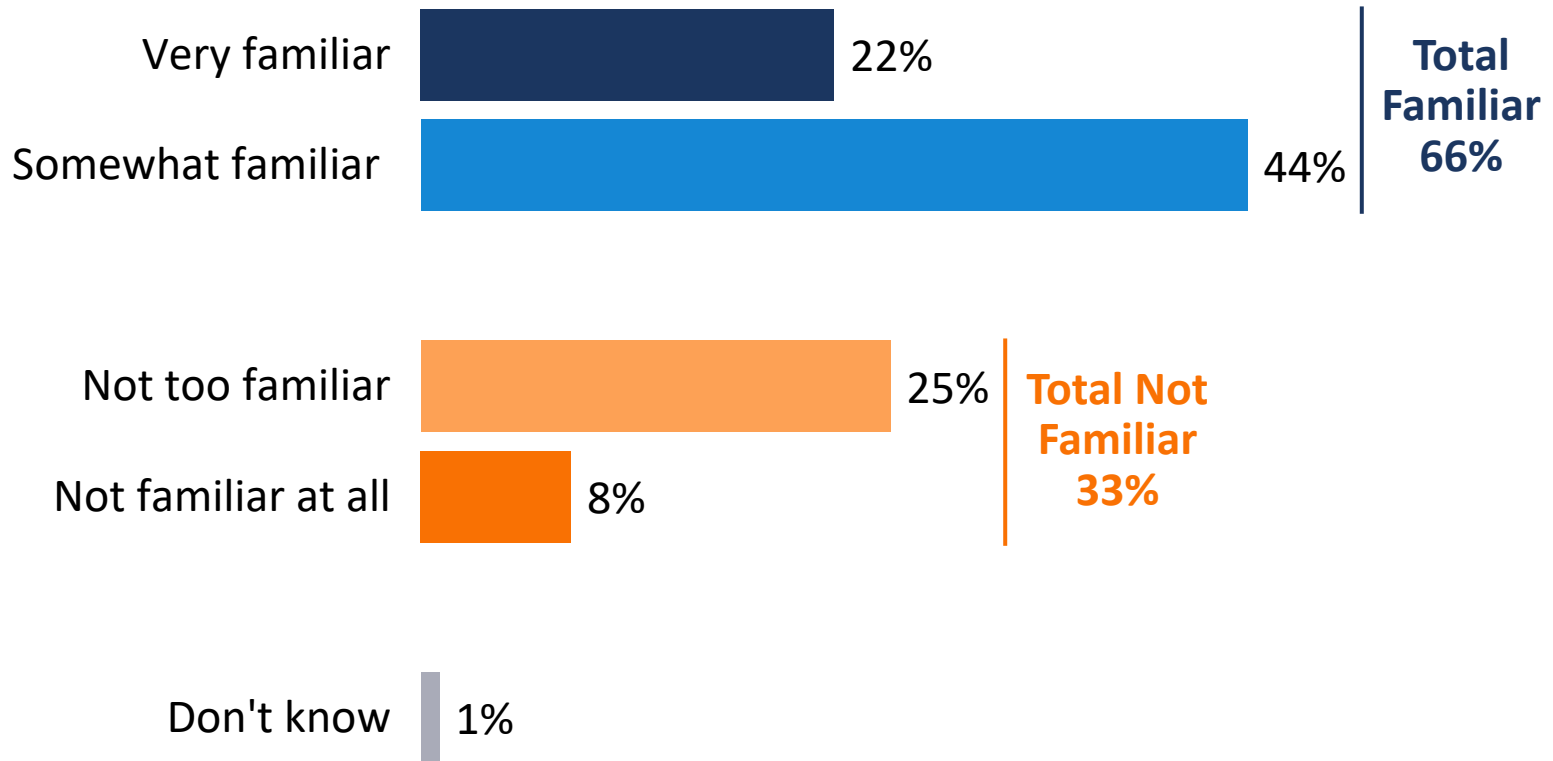

Among those able to give an opinion, reviews of Griffith Park are overwhelmingly positive.

Based on what you know, do you have an overall favorable or unfavorable opinion of Griffith Park?

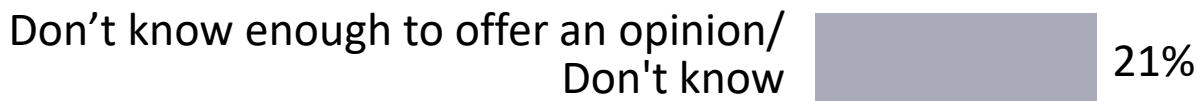
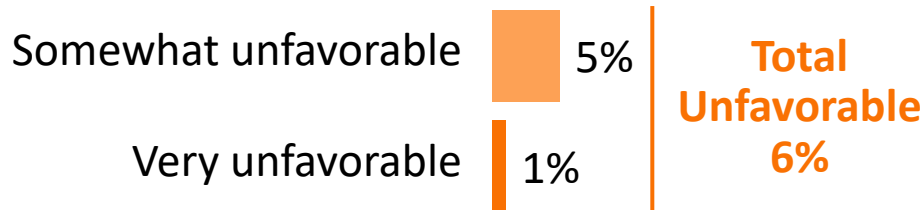

Four in 10 of those who said they have been to Griffith Park visited in the last year; and most of these recent visitors went multiple times.

(Asked Only of Those Who Said They Had Been to Griffith Park, n =488)

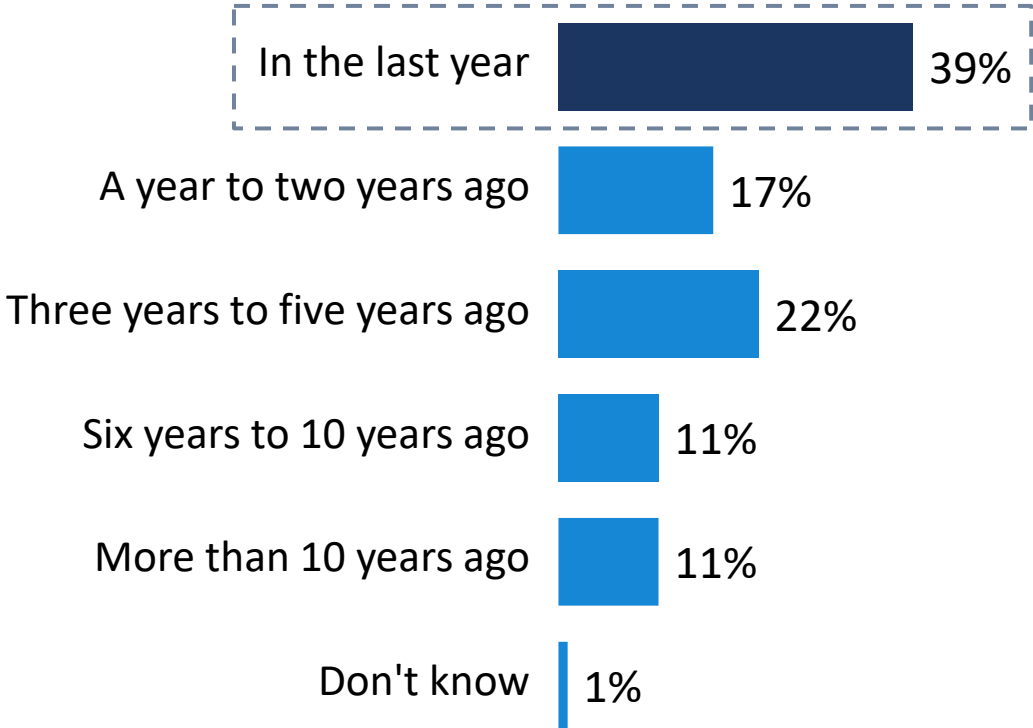

(Asked Only of Those Who said They Have Been to Griffith Park in the Last Year, n=188)

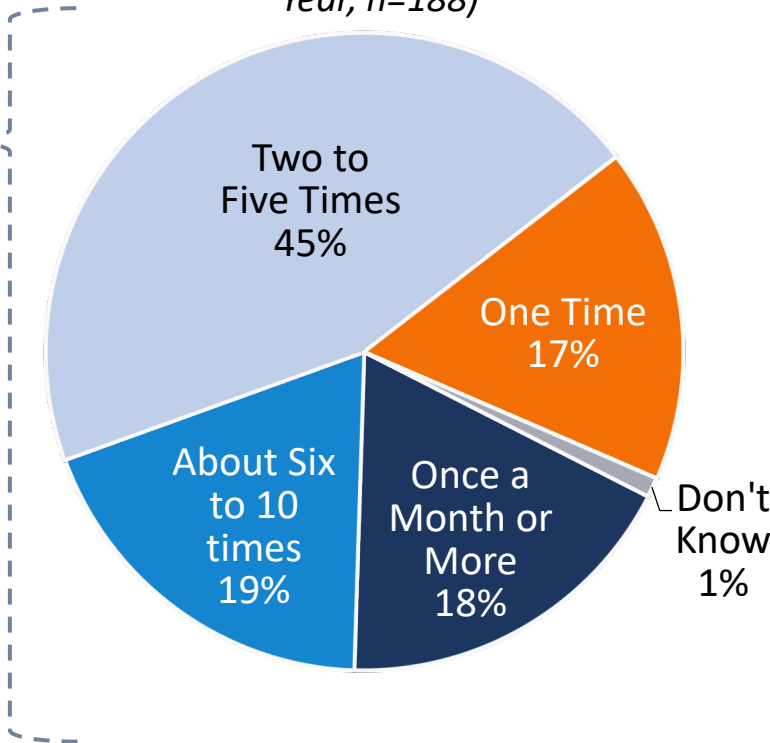

Q8. Have you visited Griffith Park in the last year, a year to two years ago, three years to five years ago, six years to 10 years ago, or more than 10 years ago?
Q9. Approximately how many times in the last year did you visit Griffith Park?

Four in 10 are very likely to visit Griffith Park in the next year; 3 in 10 are unlikely to do so.

In the next year or so, how likely do you think you are to go to Griffith Park for any reason? Please use a scale of 1 to 7 where a "1" means you are not likely at all to visit Griffith Park in the next year or so and a "7" means you are very likely to visit Griffith Park in the next year or so.

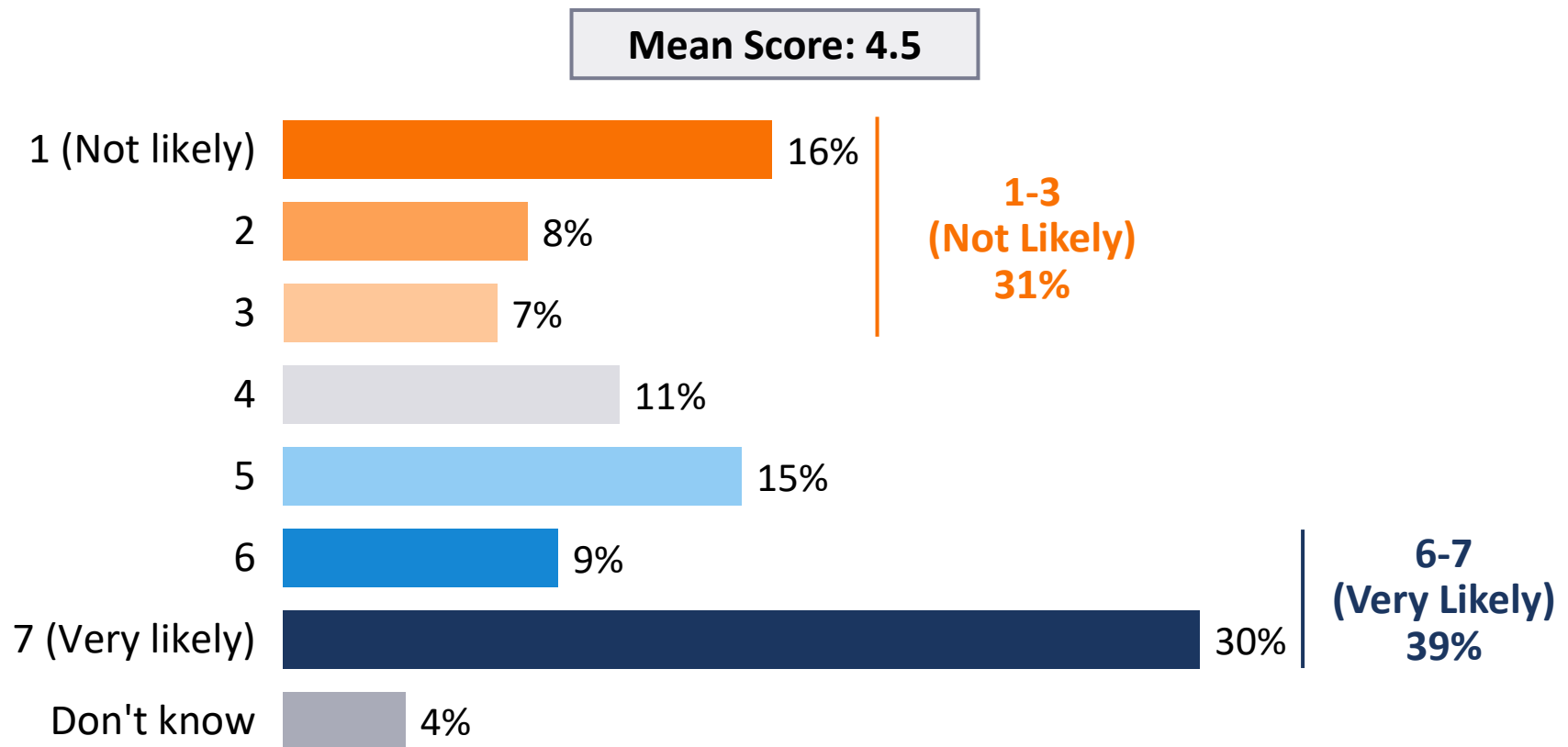

Brief Information Statement

Griffith Park is a City of Los Angeles Park. It is located just west of the I-5, roughly between Los Feliz Boulevard on the south and the 134, Ventura Freeway, on the north. The park is over 4,000 acres and includes natural areas and landscaped parkland and picnic areas. It is also the location of the LA Zoo, the Griffith Observatory, the Hollywood Sign, the Greek Theatre, and other attractions.

Three in 4 respondents have visited the Park's natural areas; 4 in 10 to half have visited the train rides, playgrounds, and the merry-go-round.

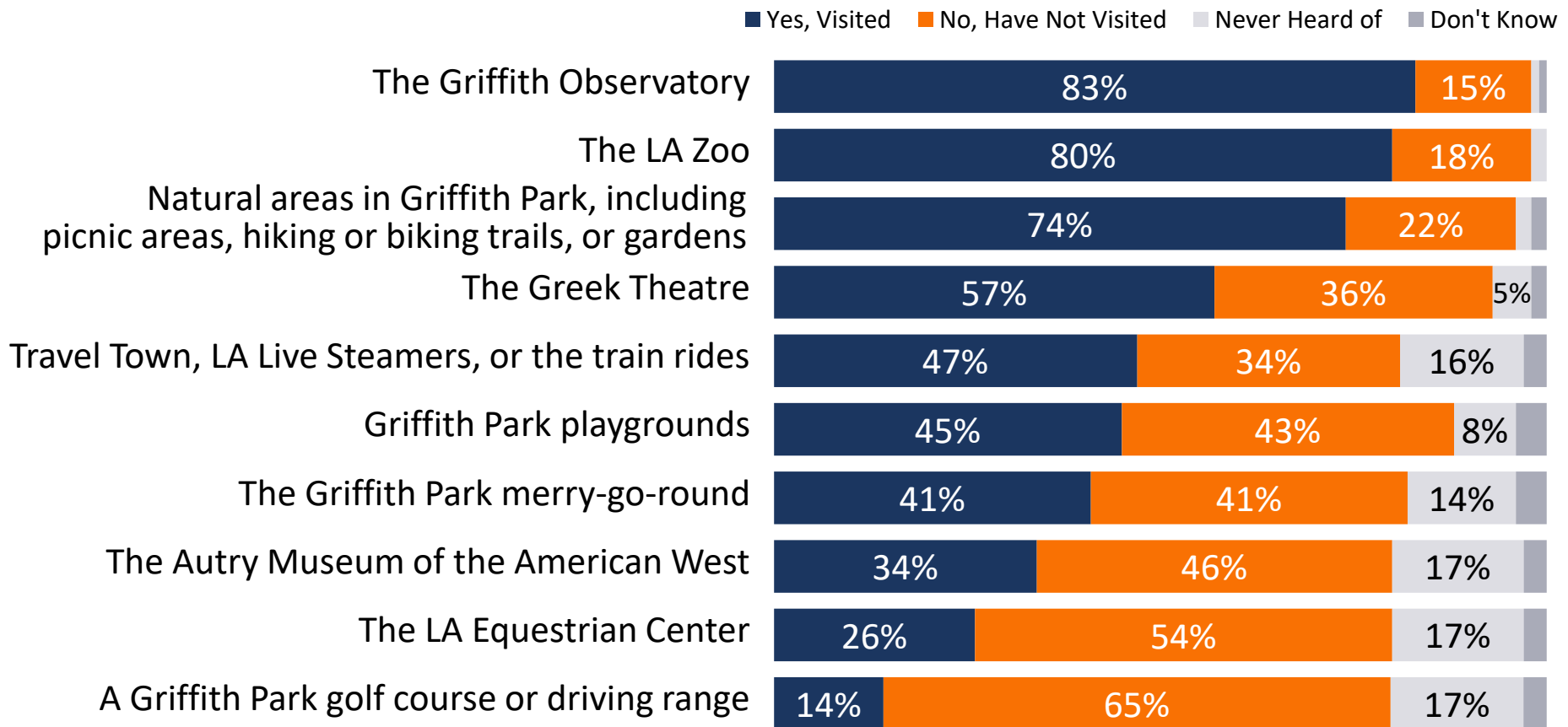

Q11. Now that you have heard more about it, I am going to read you some attractions and features that you may or may not have known are located in Griffith Park. Please tell me if you have ever visited this attraction or feature in Griffith Park. If you had never heard of an attraction or feature before I mentioned it in this survey, please tell me that instead.



Awareness of Pony Rides

Six in 10 respondents are aware of the Griffith Park Pony Ride; and 6 in 10 of those aware of the Pony Ride know it has closed.

Aware of Pony Ride

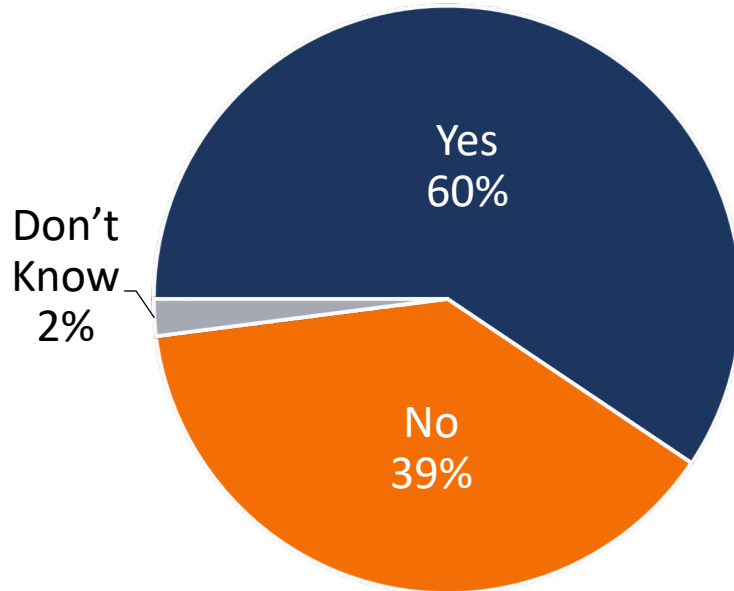

Aware of Pony Ride Closure

(Asked Only of Those Who are Aware of Pony Ride, n=336)

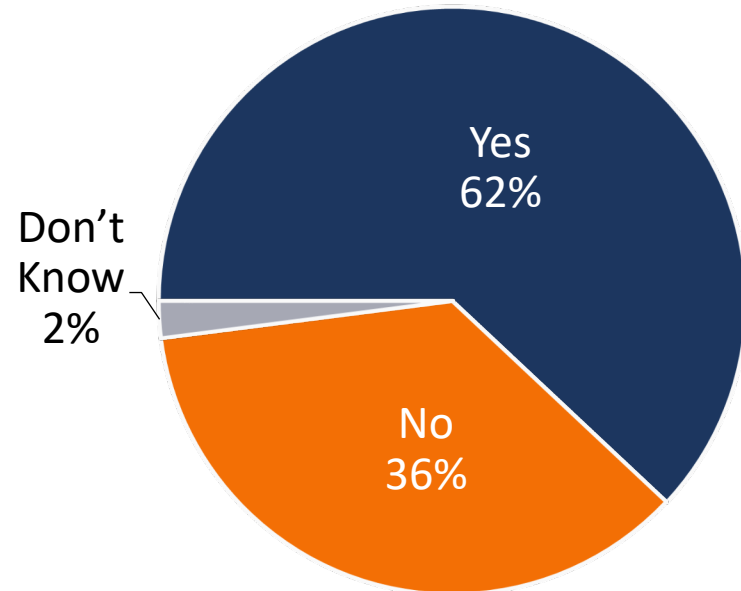

Almost 4 in 10 of All Respondents are Aware of Closure

Q12. Griffith Park previously offered pony rides in the park, but the Pony Ride was closed in December 2022. Before this survey, were you aware that pony rides were previously offered in the Park?

Q13. Many people were not aware that the Pony Ride had been closed in Griffith Park. Before I mentioned it in this survey, were you aware the Pony Ride in Griffith Park had closed?

Nearly 2 out of 3 of those aware of the Pony Ride have been to them.

Have you or anyone in your household ever visited the Griffith Park Pony Ride, whether that was in recent years or when you were a child?

(Asked Only of Those Who are Aware of the Pony Ride, n=336)

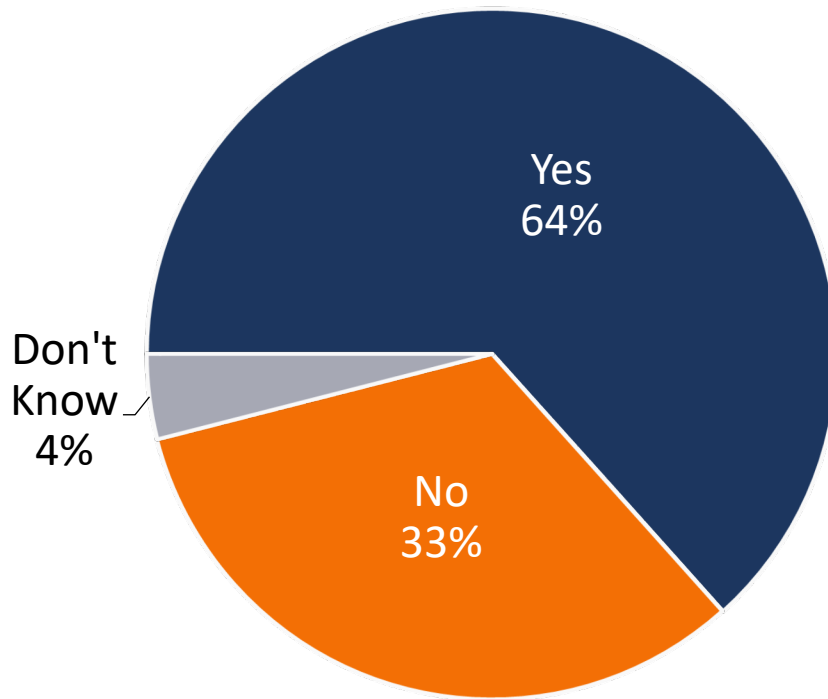

38% of All Respondents
Have Been to the Pony
Ride

Older residents and Latinos are the most likely to be aware of and to have been to the Pony Ride.

Demographic Group	Have Visited	% of Sample
All Respondents	38%	100%
Have Adult Children	58%	24%
Have Children Ages 11-18	53%	11%
Lived 30+ Years in Los Angeles	50%	48%
Latino Ages 50+	49%	12%
Downtown LA area	48%	13%
Men Ages 50+	46%	19%
Ages 65+	46%	16%
Latinos (both men and women)	45%	47%
People of Color Ages 50+	45%	21%
Ages 50+	44%	37%
Whites Ages 50+	44%	16%
Interviewed in Spanish	44%	13%
Latino Ages 18-49	43%	34%
Ages 50-64	43%	21%
Women of Color	42%	37%
Women Ages 50+	42%	18%

Nearly 8 in 10 of those who have been to the Pony Ride did so a few times or more; Six in 10 have not been in the last five years.

(Asked Only of Those Who Have Visited the Pony Ride, n=214)

How Many Times Visited

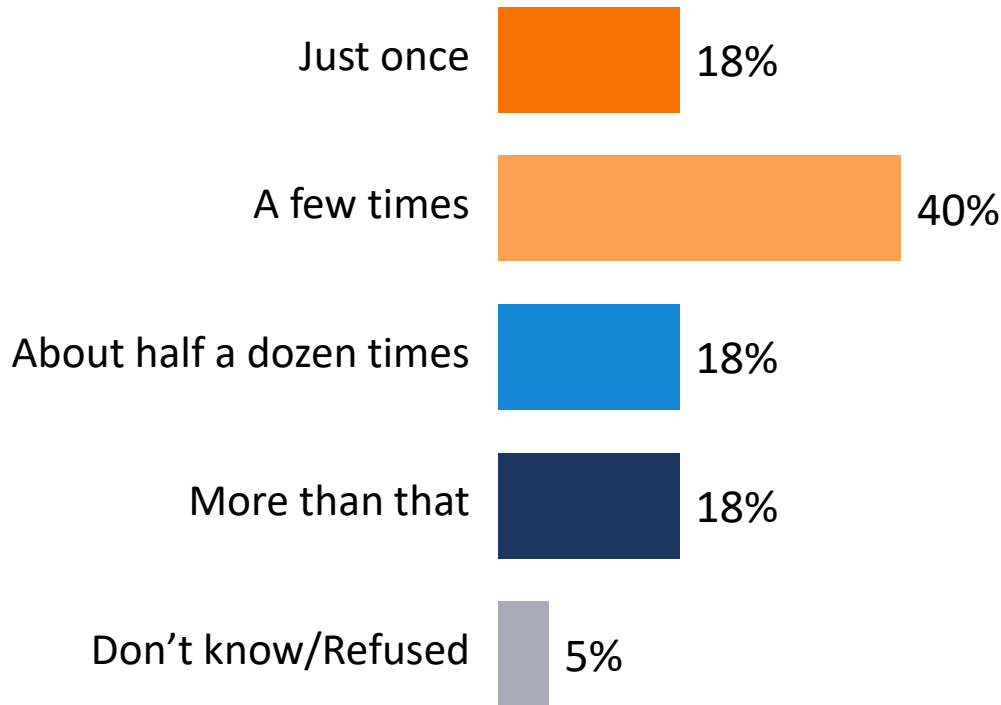

Last Time Visited

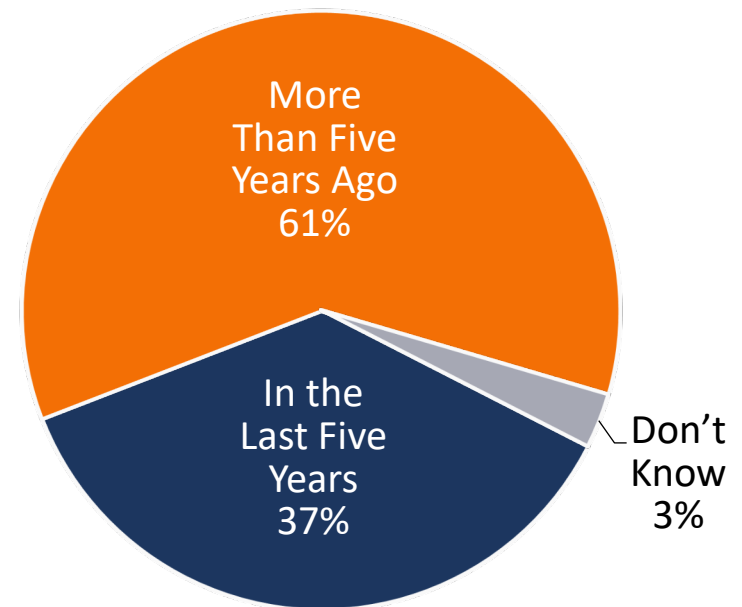

Q15. How many times have you or someone in your household visited the Griffith Park Pony Ride? Was it just once, a few times, about half a dozen times, or more than that? Your best guess is fine.

Q16. Was (your last visit to the Pony Ride) (your visit to the Pony Ride) in the last five years or more than five years ago? Your best guess is fine.

Half of respondents went to the Pony Ride as a child, and near equal numbers have taken their own children to it.

*Which of the following applies to you when thinking about the Griffith Park Pony Ride?
(Multiple Responses Accepted; Asked Only of Those Who Have Visited the Pony Ride, n=214)*

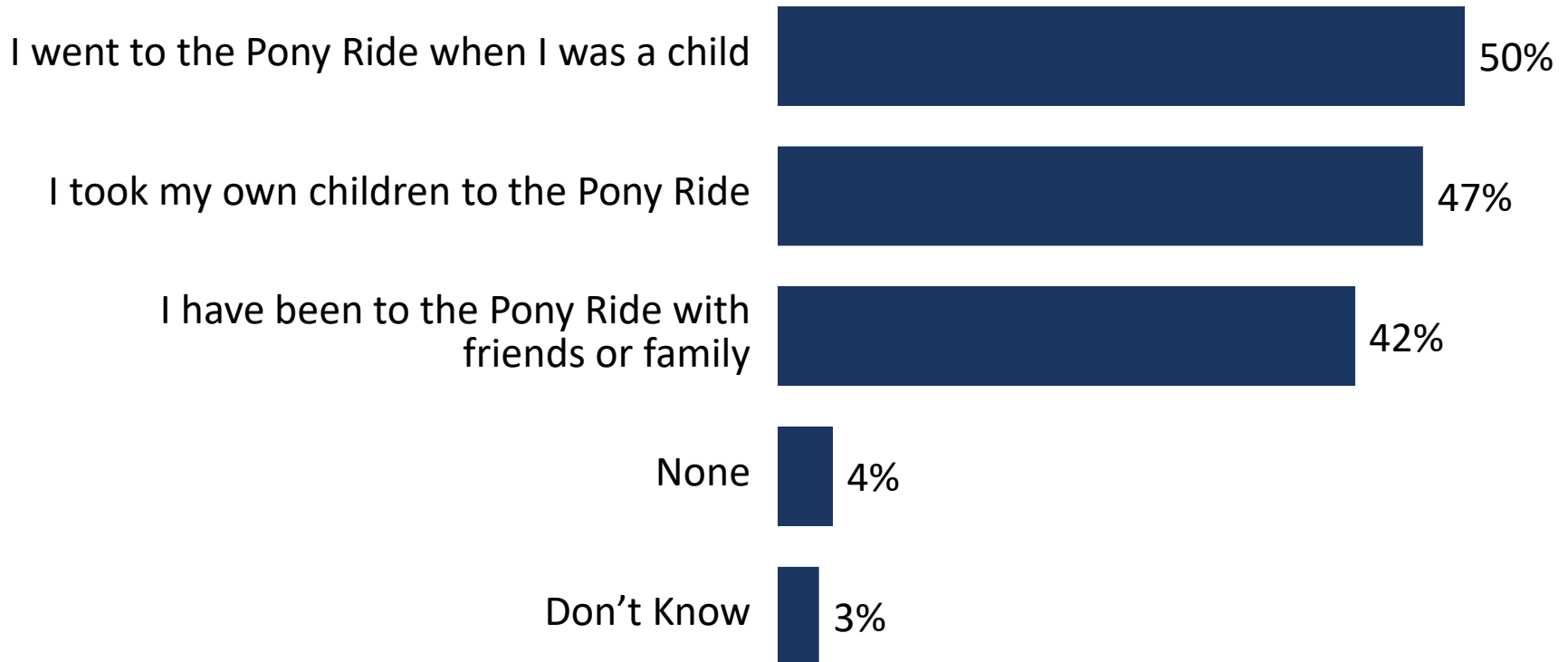



Preferred Uses of Former Pony Ride Site

The most volunteered preferred uses of the site are to bring back the pony rides and for open, natural, or recreational spaces.

The area where the Pony Ride was located is about the size of two football fields.

What would you like to see in that space in Griffith Park?

(Open-ended Question; Responses Grouped; Multiple Responses Allowed, Responses of 3% or More Shown)

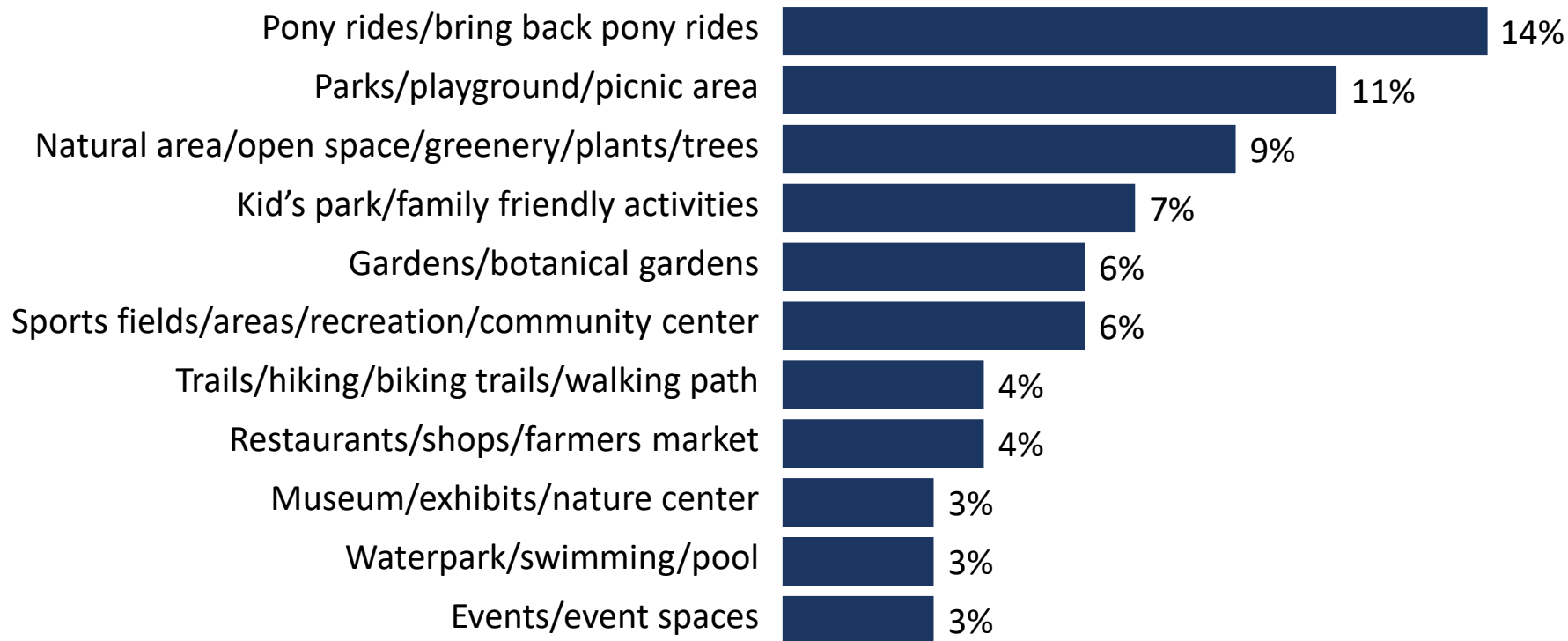

Other animal experiences were not initially top-of-mind for the site.

*The area where the Pony Ride was located is about the size of two football fields.
What would you like to see in that space in Griffith Park?*

(Open-ended Question; Responses Grouped; Multiple Responses Allowed, Responses of 2% to 0% Shown)

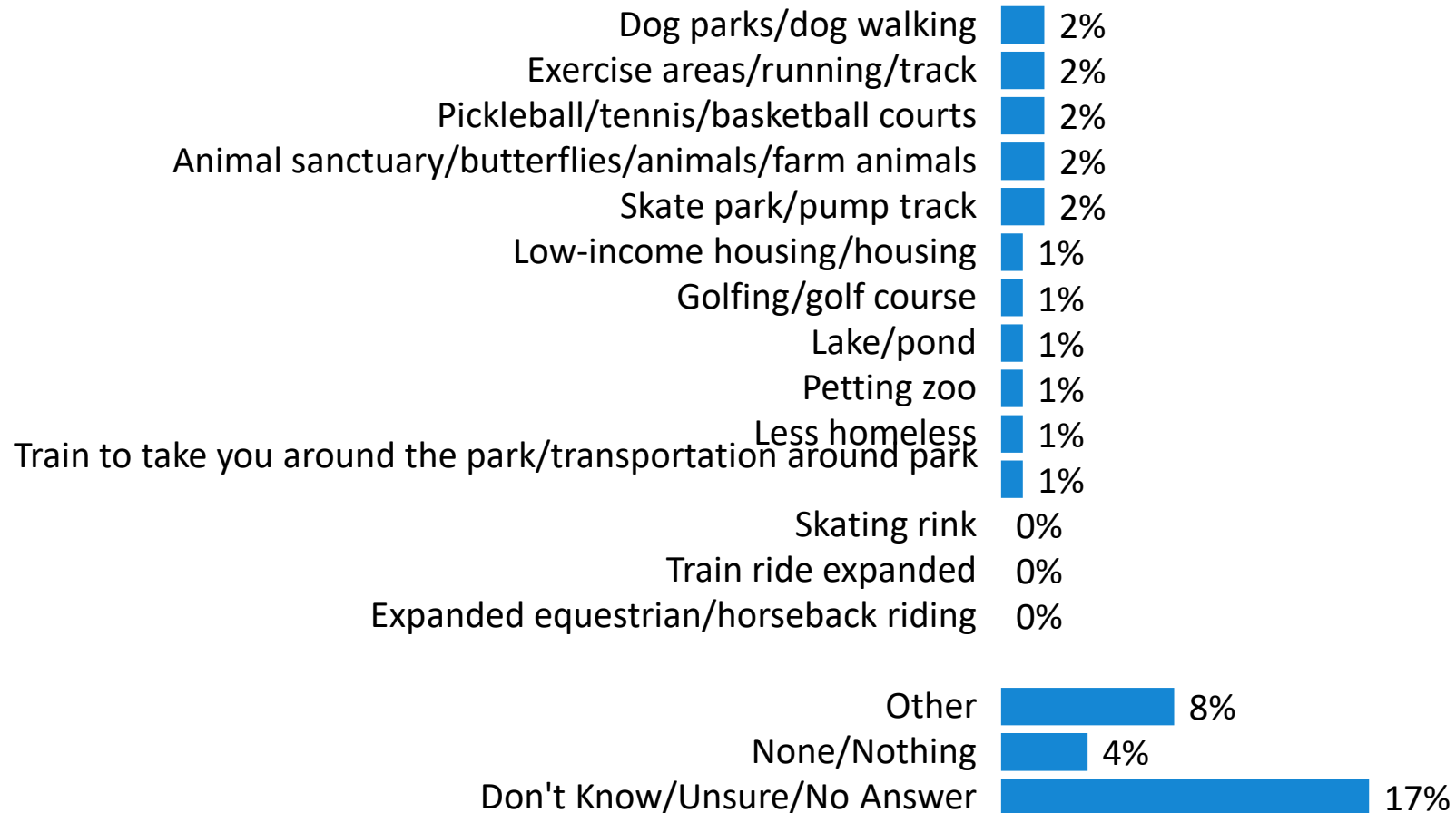

Q18. Responses 0% include actual volunteered response totaling less than 1%.

When asked directly, 7 in 10 respondents favor offering pony rides at Griffith Park again — just 16% oppose it.

Would you favor or oppose offering pony rides for children in Griffith Park again?

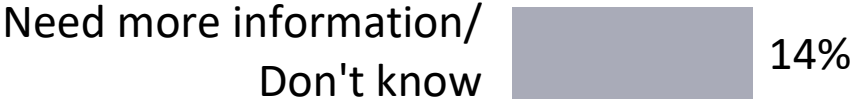

Support is strong regardless of age for offering pony rides, although 2 in 10 of those 30-49 oppose it.

(Favor/Oppose Pony Rides for Children in Griffith Park Again by Age)

■ Total Favor ■ Total Oppose ■ Need More Info./Don't Know

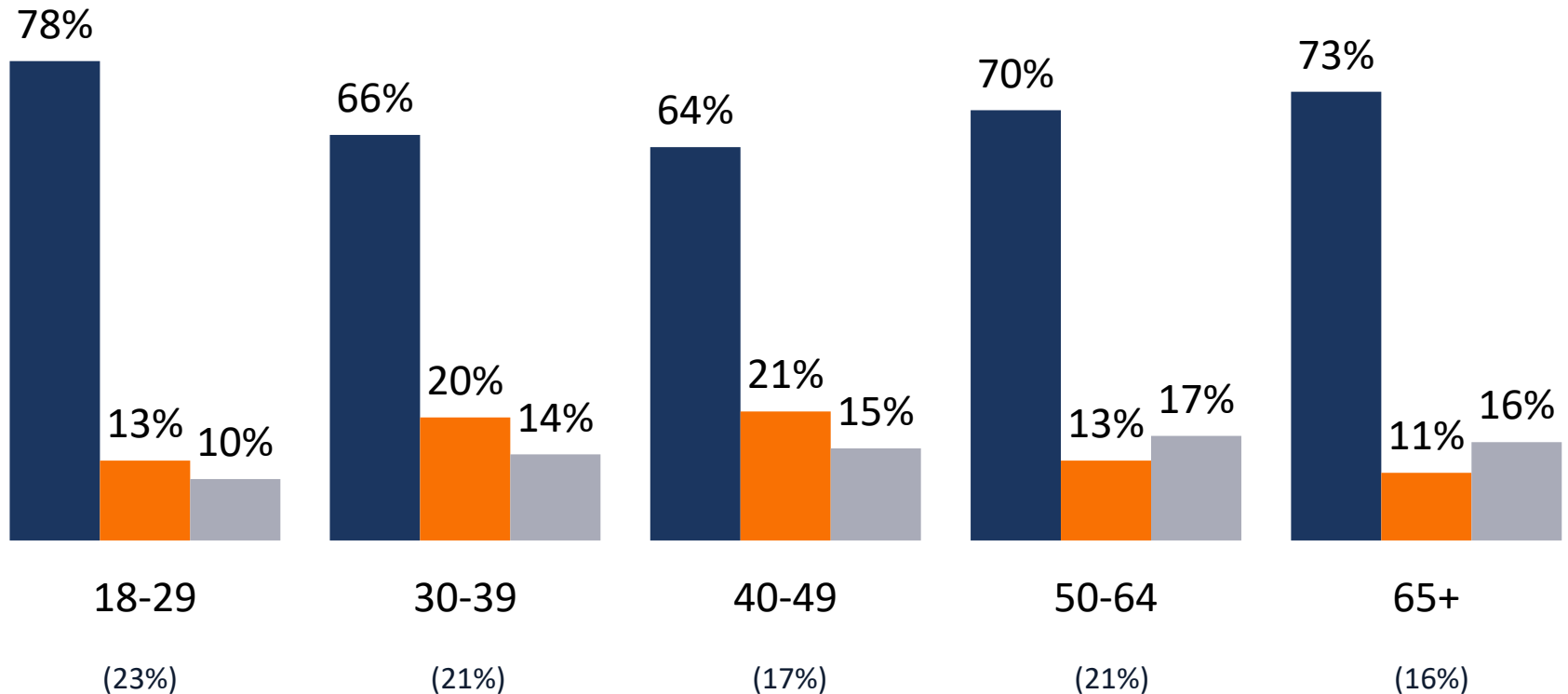

There is little difference by grouped gender and age.

(Favor/Oppose Pony Rides for Children in Griffith Park Again by Gender by Age)

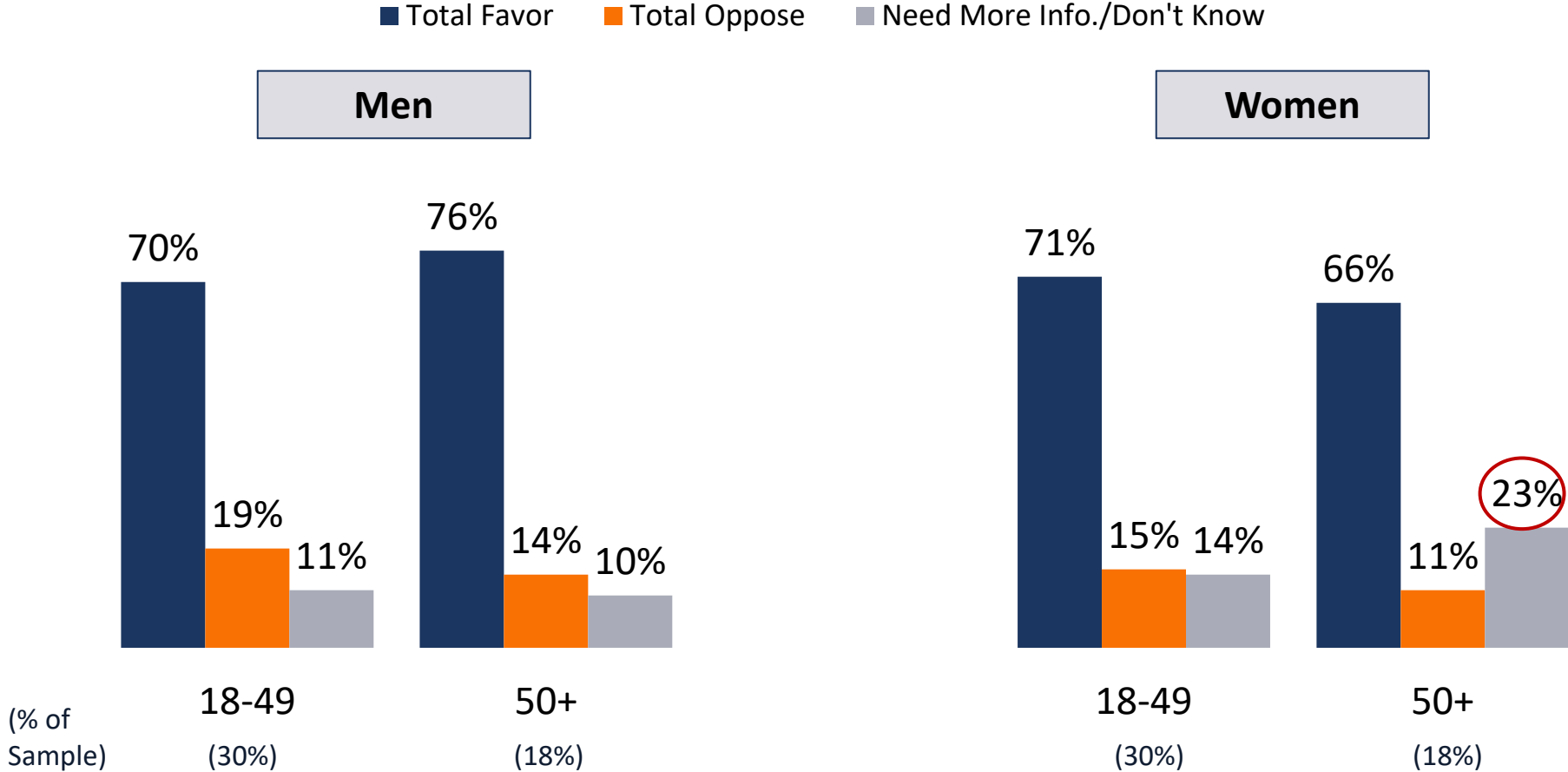

Women with children under 19 are among the most likely to favor offering pony rides again.

(Favor/Oppose Pony Rides for Children in Griffith Park Again by Parents)

■ Strongly Favor
 ■ Somewhat Favor
 ■ Total Oppose
 ■ Need More Info./Don't Know

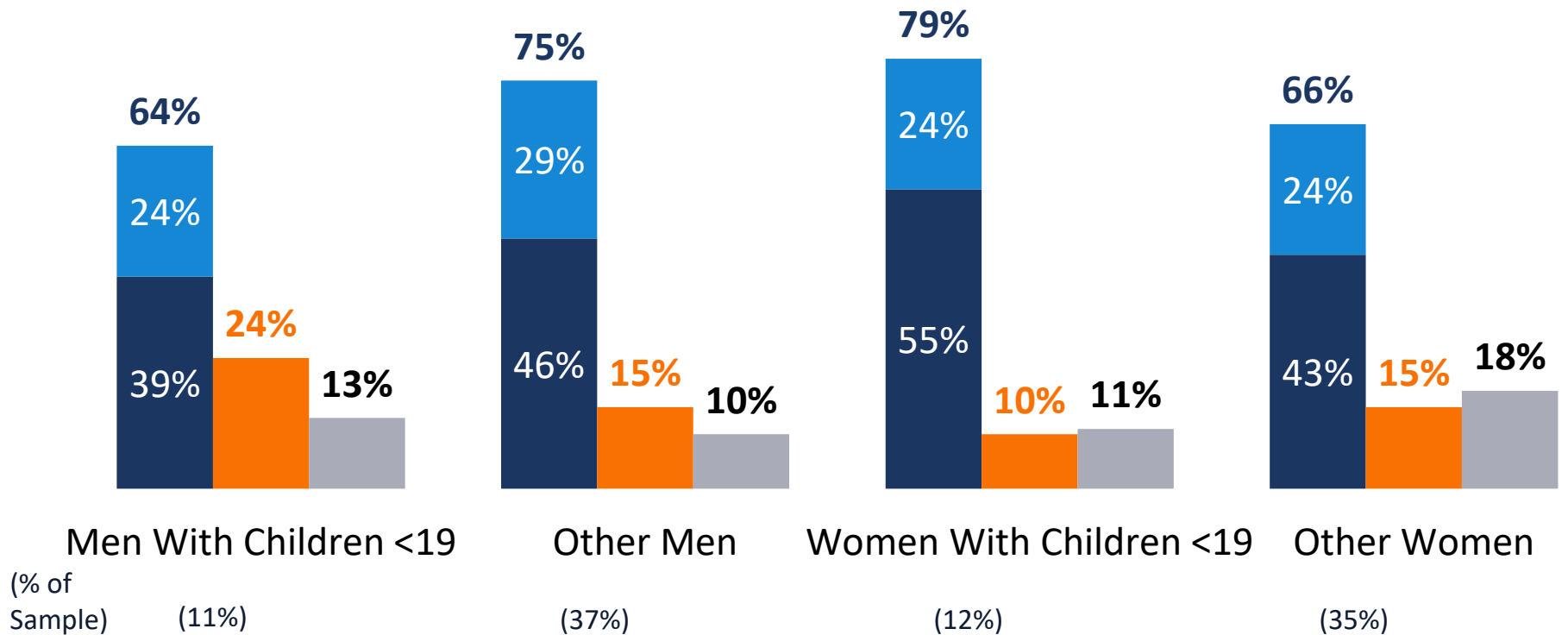

Latinos favor offering pony rides in the highest numbers.

(Favor/Oppose Pony Rides for Children in Griffith Park Again by Race/Ethnicity)

■ Strongly Favor ■ Somewhat Favor ■ Total Oppose ■ Need More Info./Don't Know

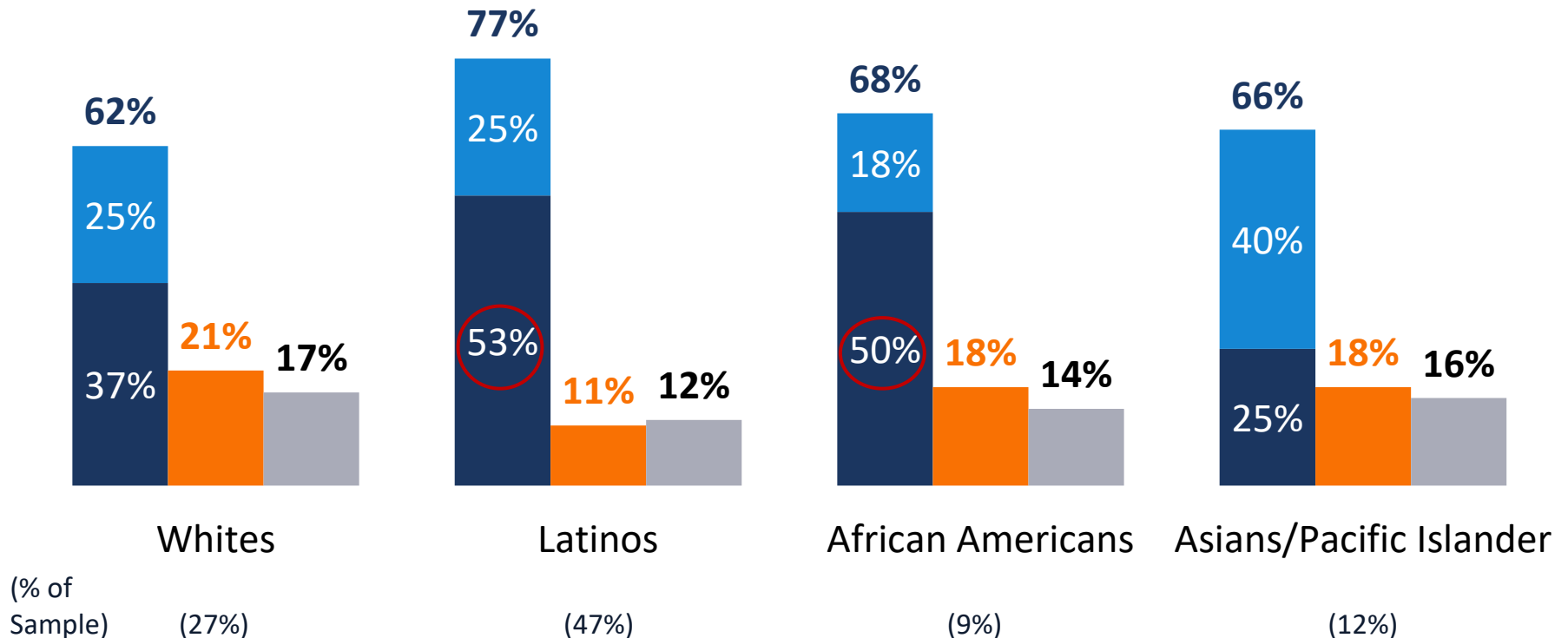

Opposition is greatest among those earning \$150K or more in household income.

(Favor/Oppose Pony Rides for Children in Griffith Park Again by Household Income)

■ Total Favor ■ Total Oppose ■ Need More Info./Don't Know

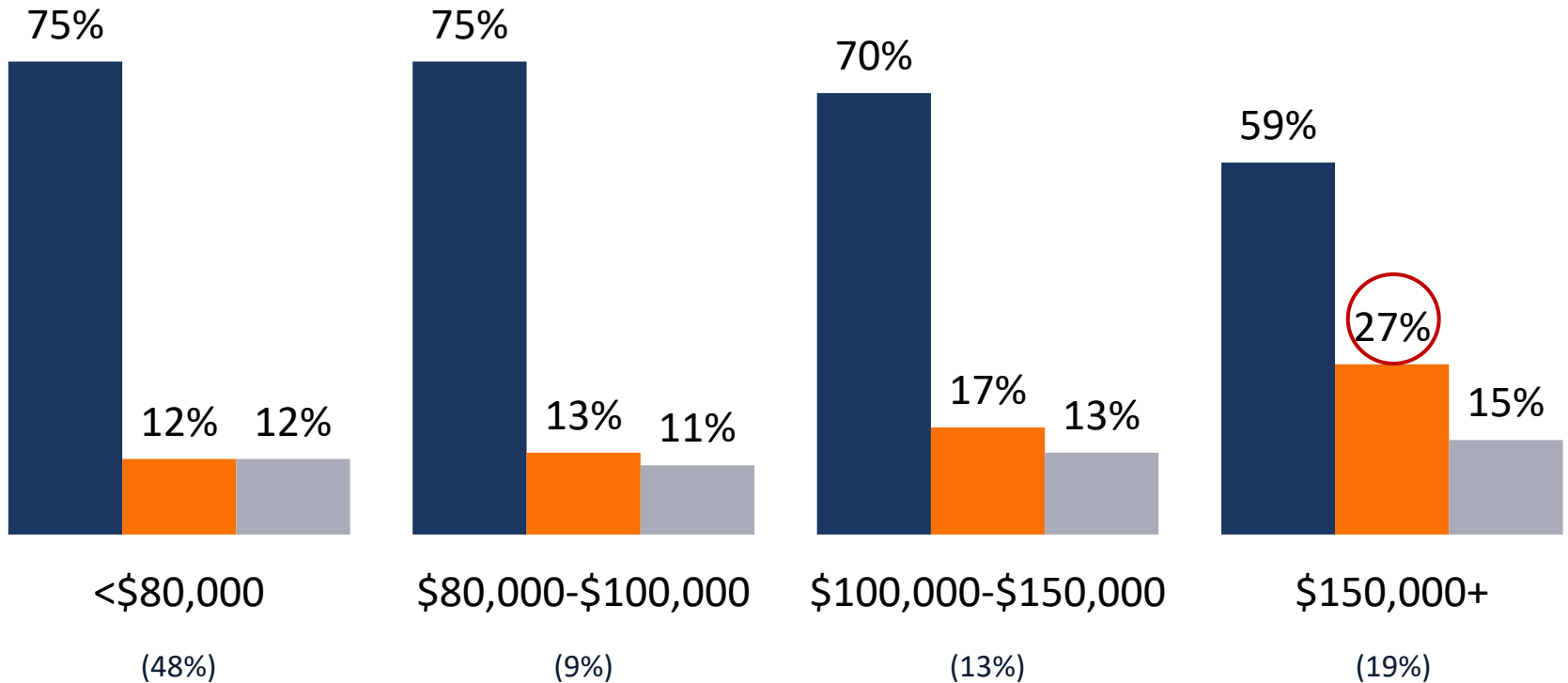

Notably, opposition is greatest among those living closest to Griffith Park.

(Favor/Oppose Pony Rides for Children in Griffith Park Again by City Zones & San Fernando Valley)

■ Total Favor ■ Total Oppose ■ Need More Info./Don't Know

City Zones

San Fernando Valley

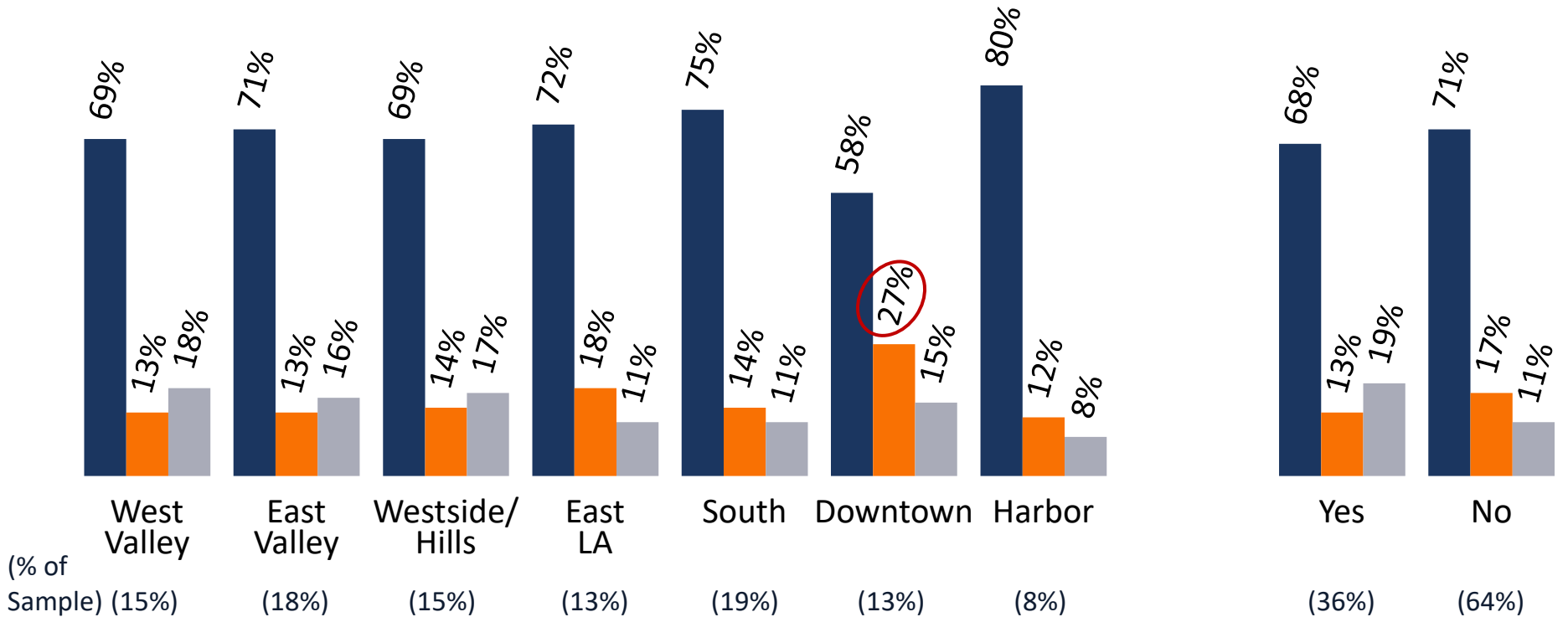

Even two-thirds of those who were not aware of the Pony Ride prior to the survey favor its return.

(Favor/Oppose Pony Rides for Children in Griffith Park Again by Pony Awareness)

■ Strongly Favor
 ■ Somewhat Favor
 ■ Total Oppose
 ■ Need More Info./Don't Know

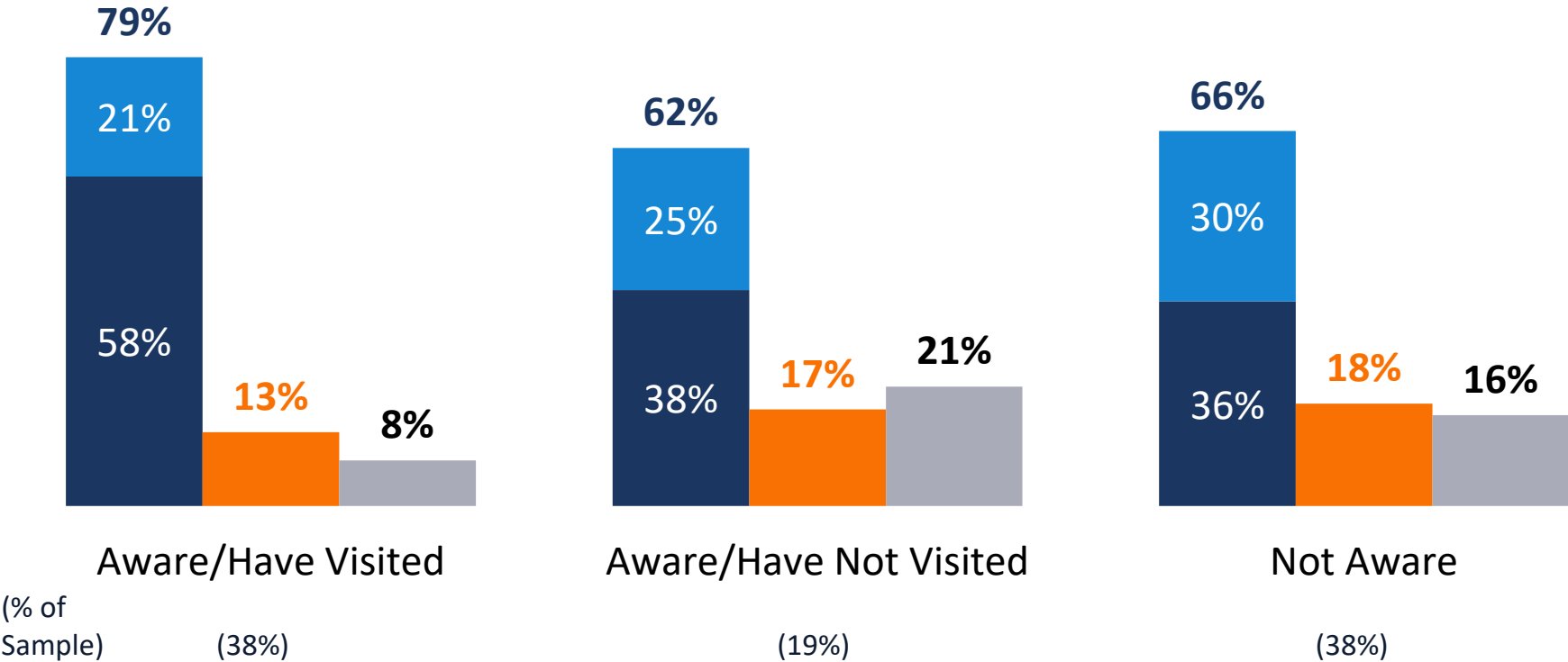

Animal rescue, community garden, museum, adventure course, and pony ride top the list of proposed uses of site when provided a list of options.

(Ranked by 6-7, Very Appealing)

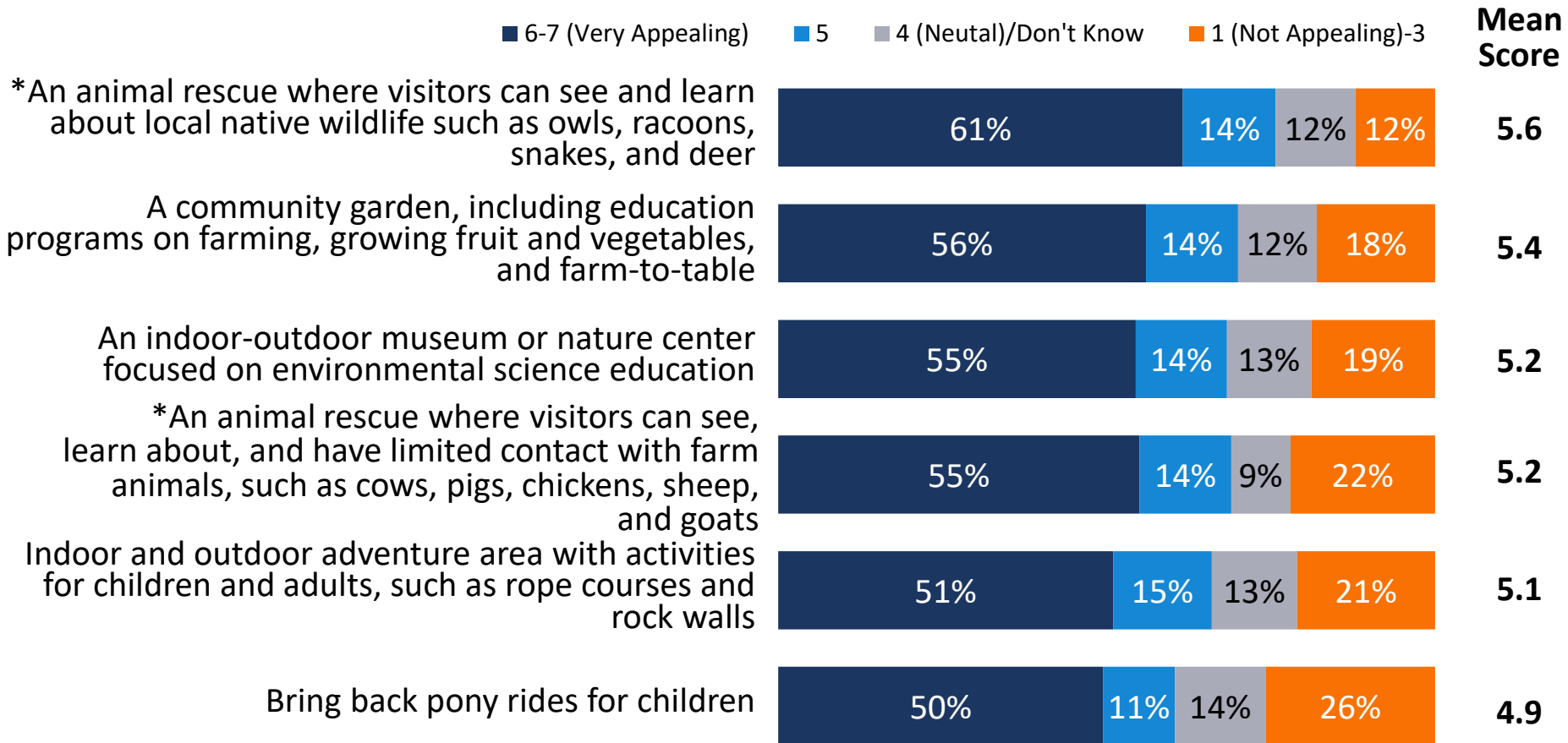

Q20. I am going to read you a list of proposals that some people have suggested for how to use the site once occupied by the pony rides in Griffith Park. All the proposed attractions or features would be at low to no cost to park visitors. Please tell me how appealing the proposed feature or attraction is to you, using a scale of 1 to 7 where a "1" means it is not appealing at all and a "7" means it is very appealing. You can choose any number from 1 to 7.

Continued

(Ranked by 6-7, Very Appealing)

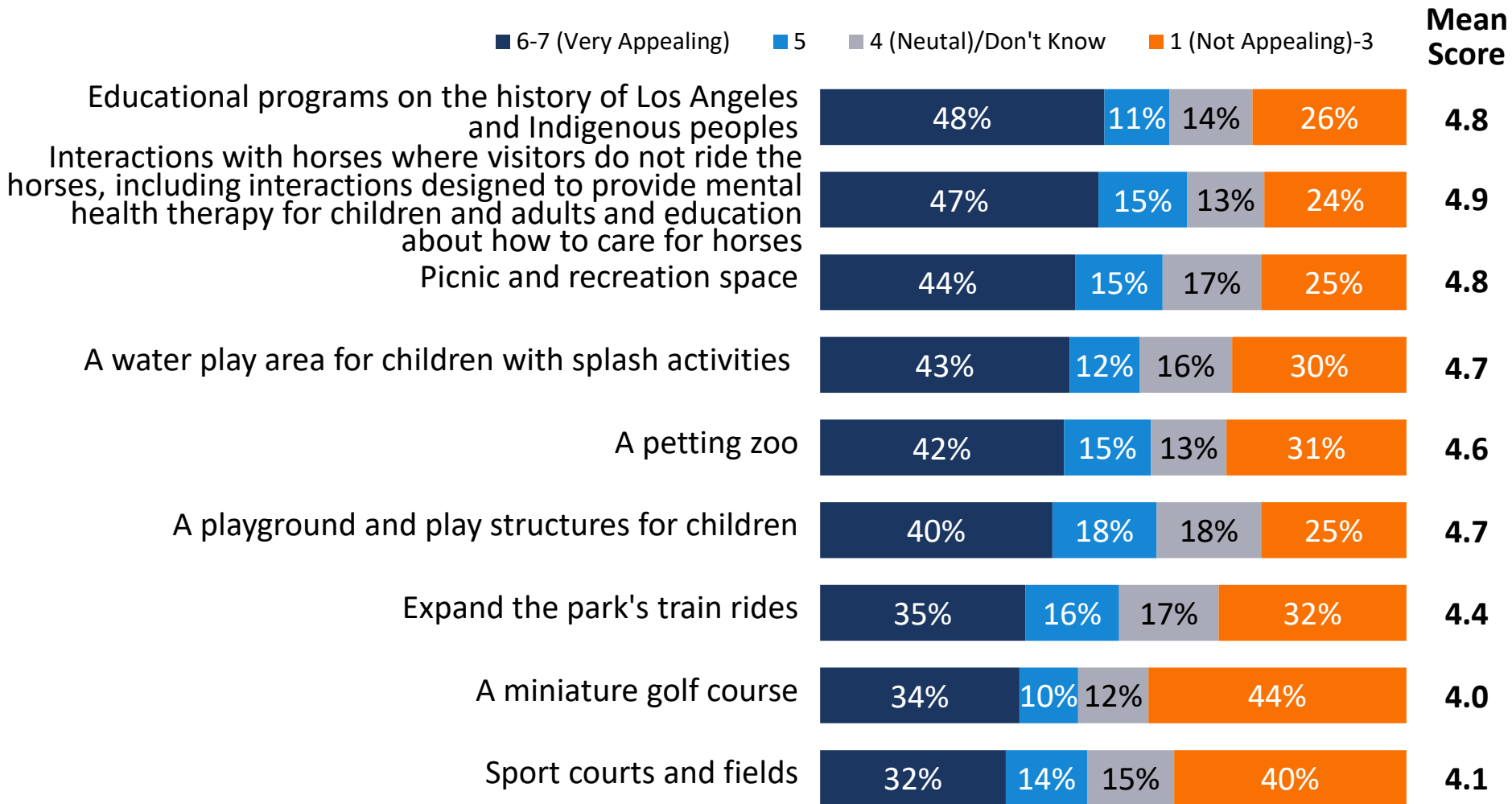

Q20. I am going to read you a list of proposals that some people have suggested for how to use the site once occupied by the pony rides in Griffith Park. All the proposed attractions or features would be at low to no cost to park visitors. Please tell me how appealing the proposed feature or attraction is to you, using a scale of 1 to 7 where a "1" means it is not appealing at all and a "7" means it is very appealing. You can choose any number from 1 to 7.

Nine in 10 respondents find at least three proposals very appealing; slightly more than 4 in 10 feel this way about seven or more—showing the opportunity for multiple uses of the site.

(% 6 or 7 Rating Indicating Very Appealing)

Proposals

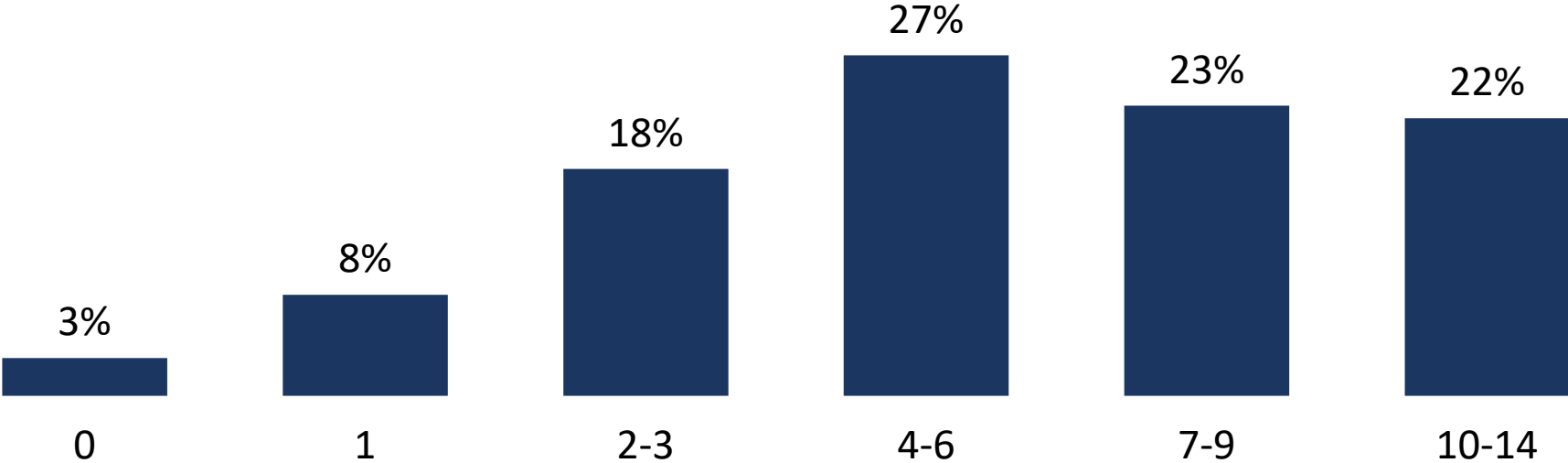

After hearing more options for the space, educational and animal experiences are the most volunteered preferred uses.

(Open-ended Question; Responses Grouped; Responses of 4% or More Shown; Asked Only Online, n=313)

<i>Having heard more, what would you like to see at the site of the former Pony Ride in Griffith Park — whether something you heard about in the survey or something that was not mentioned?</i>	<i>%</i>
Educational purposes/center; indigenous/nature/environmental/science education/museum	16%
Animal sanctuary/animal rescue/something with animals/wildlife center/horse therapy	13%
Pony rides/bring back pony rides	12%
Activities for kids/playground	8%
Community garden/gardening/farming education	8%
Sports areas/fields/courts/complex	6%
Botanical gardens/gardens	5%
Splash/water park/water play	5%
Recreation/picnic areas (passive park space mentions)	5%
Nature areas	4%
Petting zoo	4%
All interesting ideas/good ideas	5%
Other	17%
None/Nothing	10%
Don't Know/Unsure/Refused/No Comment	5%

Of those who do not favor pony rides in Griffith Park, just two in 10 oppose any kind of animal experience.

(Asked Only of Those Who Did Not Favor Offering Pony Rides in Griffith Park, n=167)

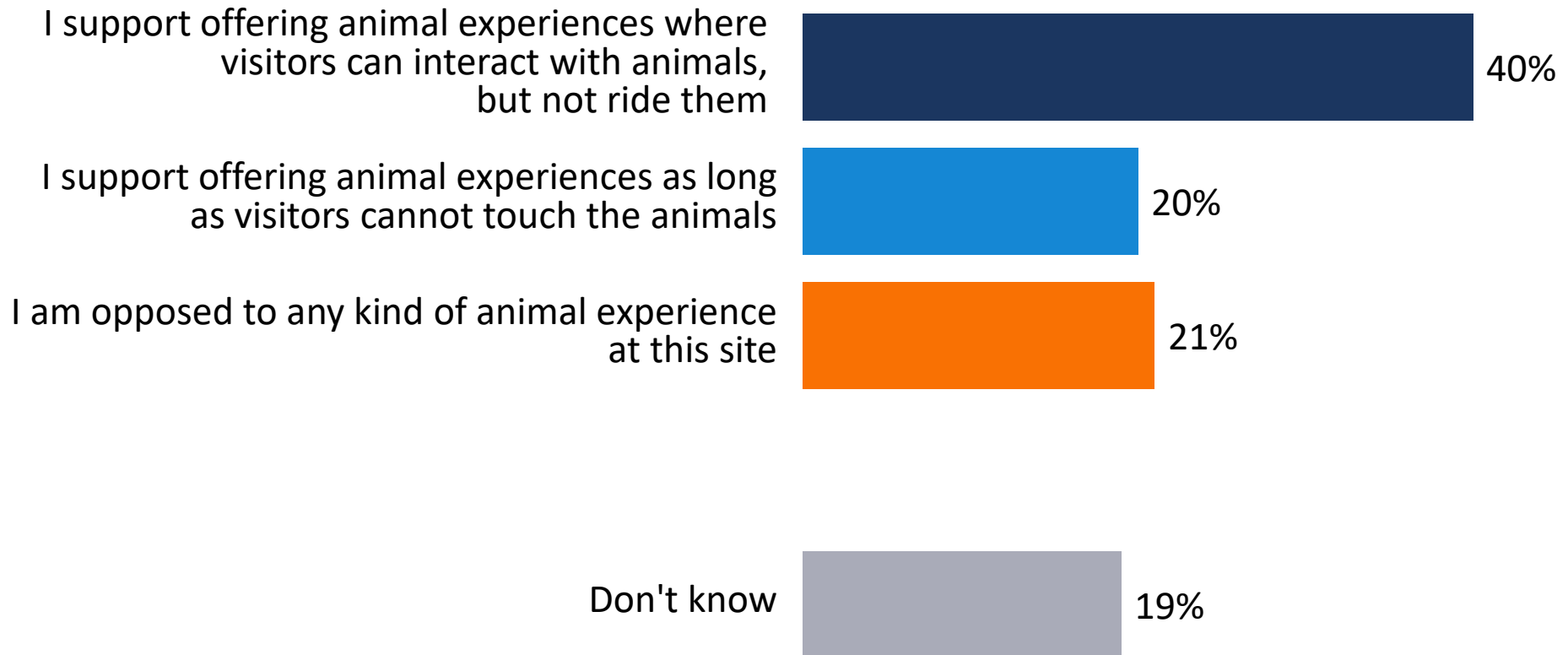

Of all respondents, just 6% oppose any kind of animal experience.

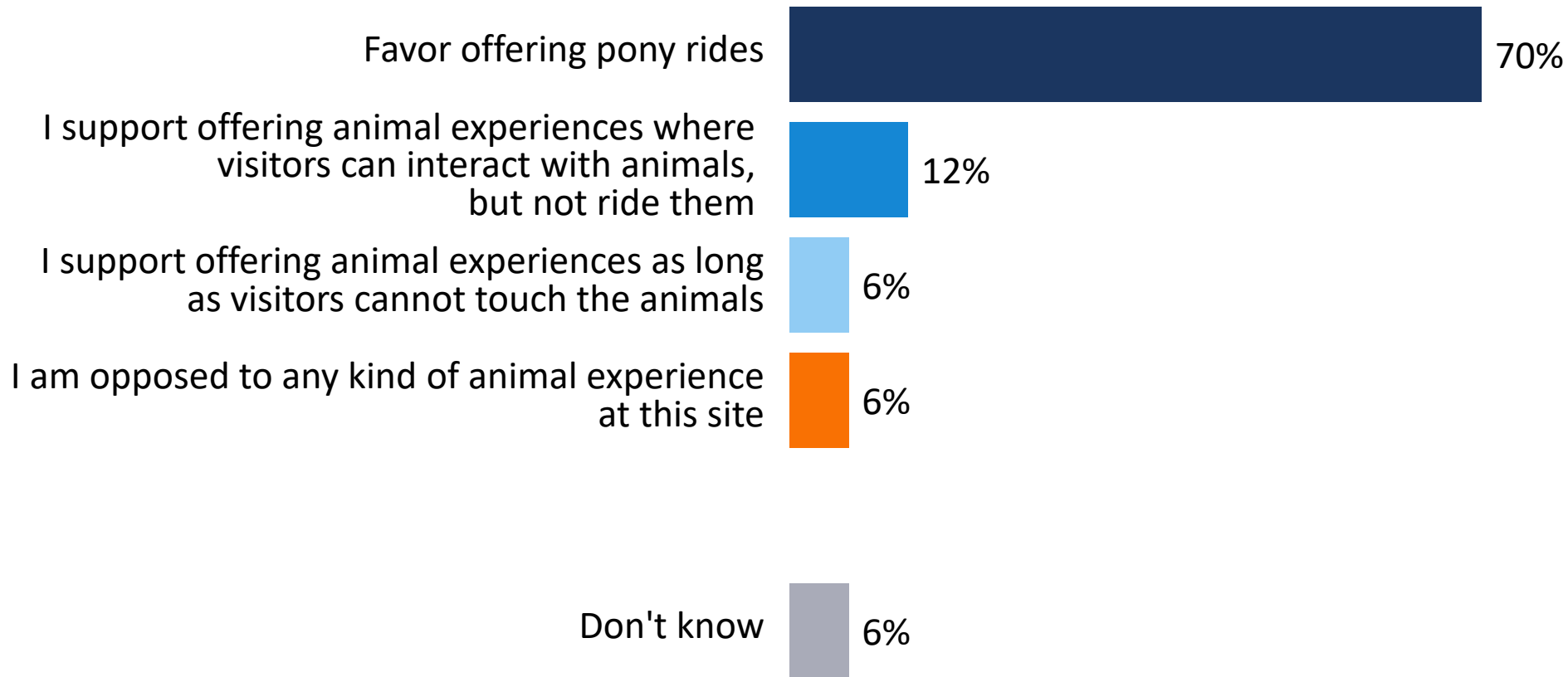



Demographics

Gender

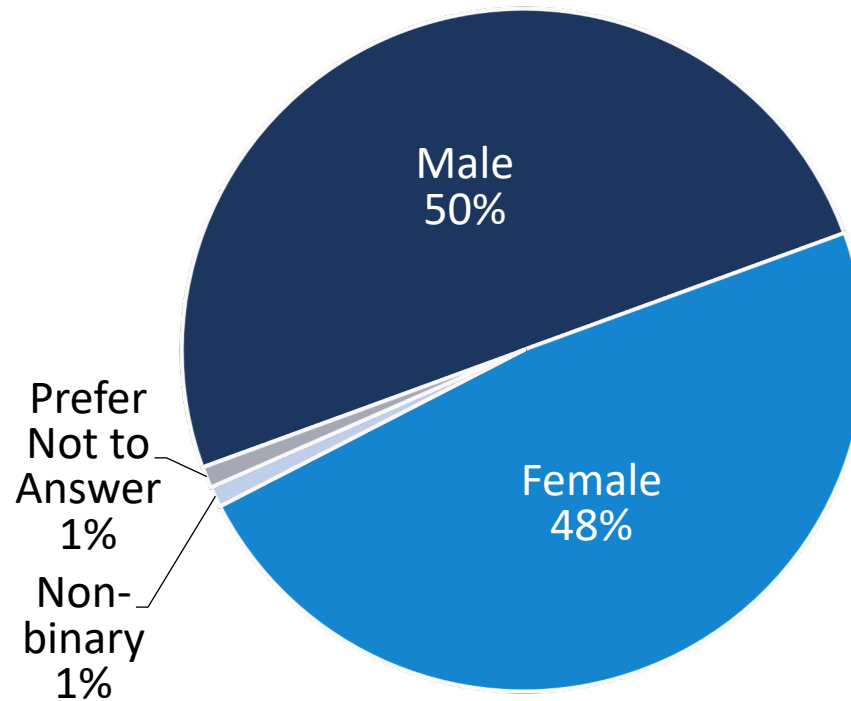

Race/Ethnicity

Which of the following categories best describes the ethnic or racial group with which you identify yourself?

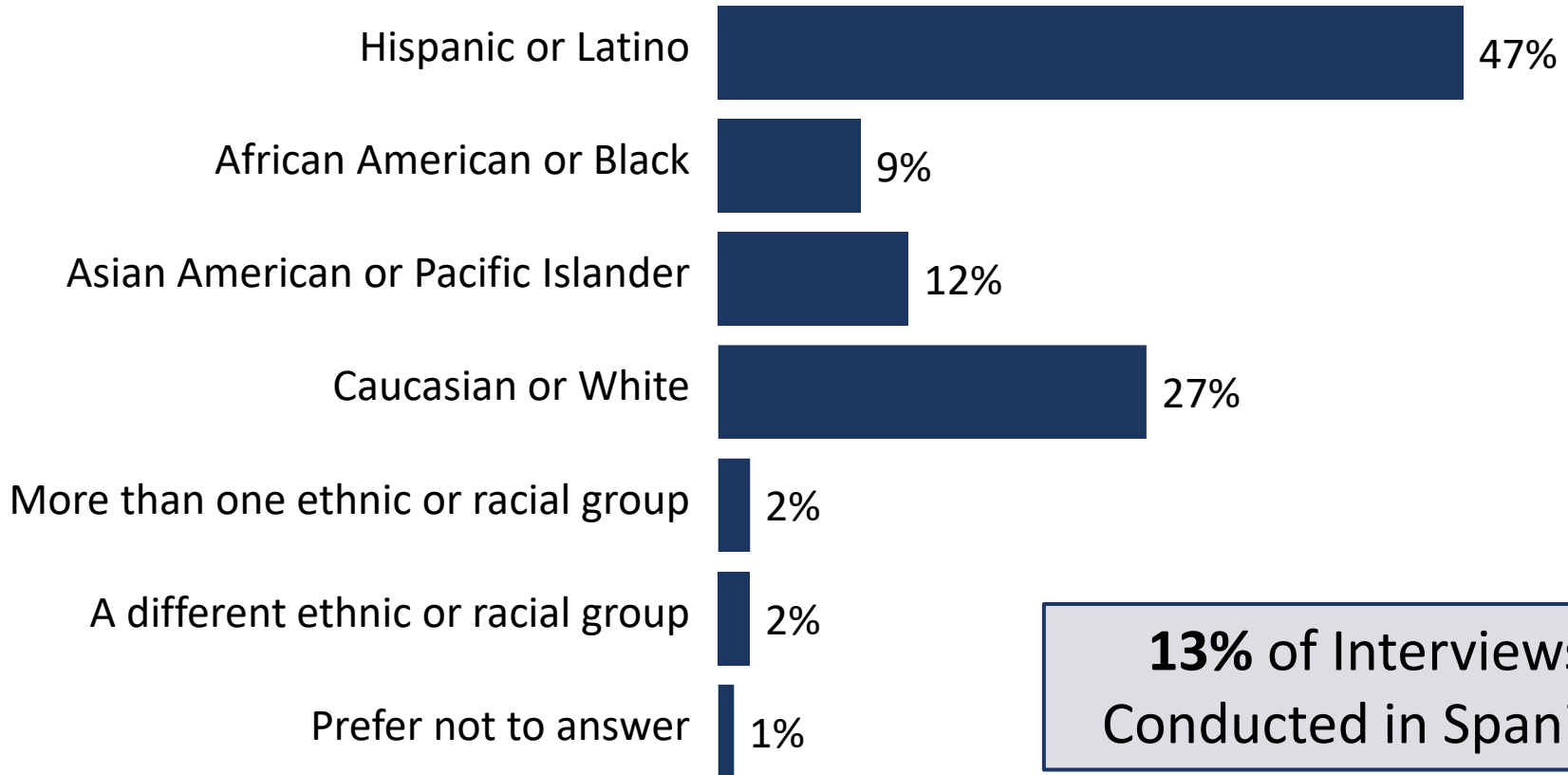

Age

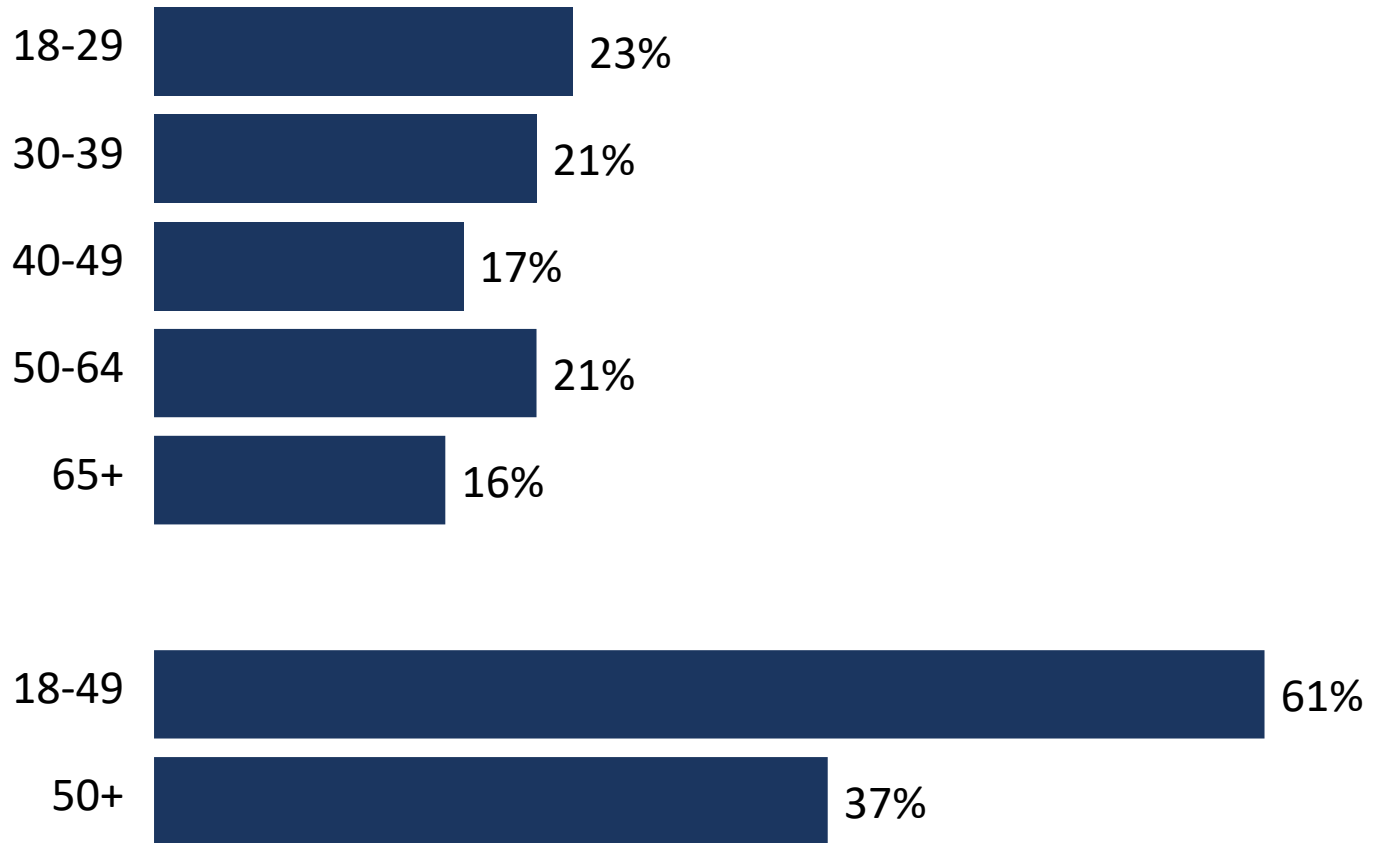

City Areas

City Zones

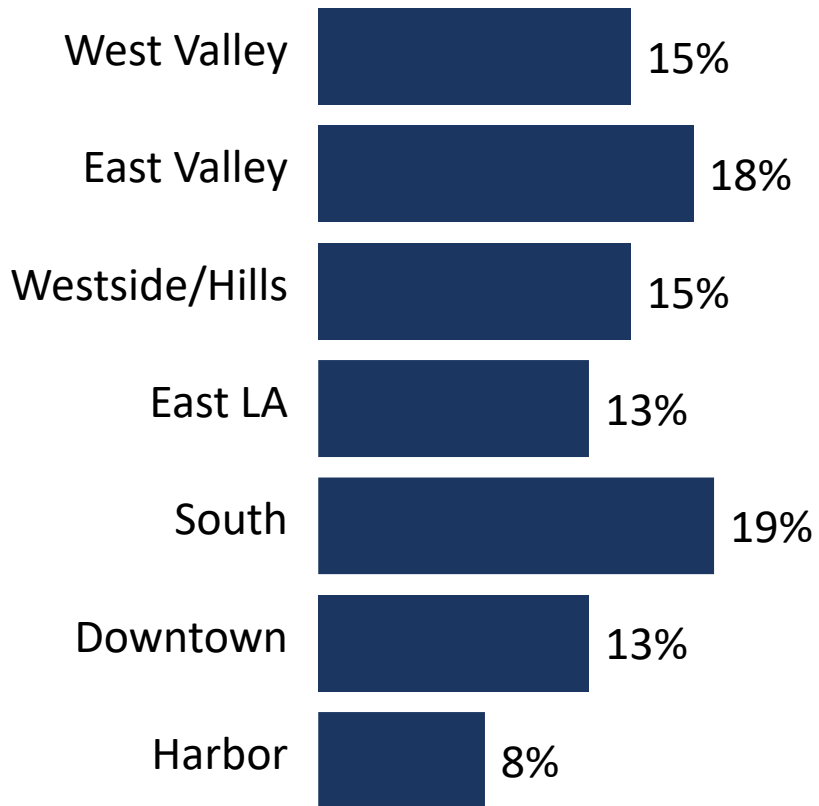

San Fernando Valley

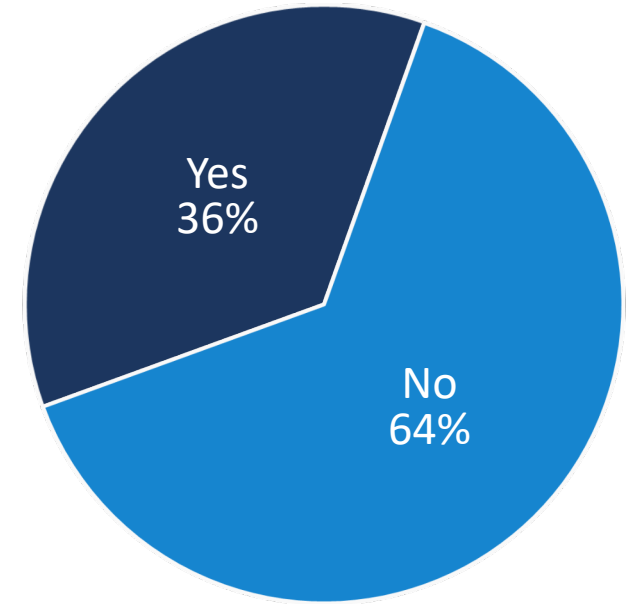



Conclusions

Conclusions

- Griffith Park is well-known and well-regarded.
- Nearly all respondents have been to Griffith Park—although nearly half have not been in over three years—and most having visited more than one attraction.
- There is high awareness of the Griffith Park Pony Ride, with 6 in 10 aware of it.
- Among those familiar with the Griffith Park Pony Ride, 6 in 10 are also aware that the Pony Ride closed.
- Nealy 4 in 10 of all respondents have visited the Pony Ride—with respondents ages 50 or older and Latino respondents among the most likely to have done so.
- Half of respondents who have been to the Pony Ride, went when they were a child as well as half taking their own children—showing the long-standing tradition for many.

Conclusions; Continue

- Seven in 10 respondents favor bringing back the pony rides.
- The results also suggest there is a low level of opposition to animal experiences in general, with just six percent opposed to any kind of animal experience.
- Most respondents find more than one proposed use of the site appealing—with 3 out of 4 feeling this way about four or more proposals. This suggests the opportunity to provide multiple experiences at the former Pony Ride site or extended area that would be attractive to visitors.
- Top proposals are an animal rescue, community garden, indoor-outdoor museum or nature center, adventure area, and pony rides.
- Paved proposals, including sports courts/field, miniature golf, expanded train rides, water play, and play structures are well-received but have lower appeal—perhaps also because of their more narrow audience (primarily youth).

City of Los Angeles Griffith Park Study

January 28-February 4, 2024



OPINION
RESEARCH
& STRATEGY

Appendix K.

Publicly available Online Survey Results

December 7, 2022 through
June 5, 2023



CITY OF LOS ANGELES GRIFFITH PARK SURVEY
320-1111-WT
N=4609
MARGIN OF SAMPLING ERROR ±4.4% (95% CONFIDENCE LEVEL)
CONSULTANT WORKING DRAFT NOT FOR PUBLICATION. CA GOV'T CODE 7927.

Hello, I'm calling from _____, a public opinion research company. We are not telemarketers trying to sell anything or ask for a donation of any type. We're conducting a public opinion survey about issues that concern City of Los Angeles residents. May I speak to _____? **(IF NOT AVAILABLE, ASK WHEN IT WOULD BE CONVENIENT TO CALL AGAIN.) (IF RESPONDENT REPLIES IN SPANISH, OR DESIRES TO SPEAK IN SPANISH, FOLLOW THE ESTABLISHED PROCEDURE FOR HANDING OFF TO A SPANISH-SPEAKING INTERVIEWER.)**

A. Before we begin, I need to know if I have reached you on a cell phone. **(IF YES, ASK: "Are you in a safe place where you can talk?")**

- Yes, cell and in safe place-----0%
- Yes, cell not in safe place ----- **TERMINATE**
- No, not on cell -----0%
- (DON'T READ) DK/REFUSED---** **TERMINATE**

1. To confirm you live in the City of Los Angeles, could you please tell me your zip code? **(OPEN-END) (TERMINATE IF NOT IN ONE OF CITY OF LA ZIP CODES ON FILE OR UNSURE/NA/RESFUSED)**

2. Now, just to make sure everyone is represented in this survey, what is your gender? **(OPEN-END; RECORD VERBATIM RESPONSES)**

- Male----- 18%
- Female ----- 77%
- Non-binary ----- 1%
- (DON'T READ) Prefer not to answer ---**4%

3. Again, just to make sure everyone is represented, which of the following categories best describes the ethnic or racial group with which you identify yourself? Is it...? **(READ ALL RESPONSE CHOICES; DO NOT RANDOMIZE)**

- Hispanic or Latino ----- 16%
- African American or Black -----2%
- Asian American or Pacific Islander -----7%
- Caucasian or White----- 56%
- More than one ethnic or racial group-----7%
- A different ethnic or racial group **(SPECIFY AND RECORD: _____)** ----2%
- (DON'T READ) Prefer not to answer-----** 10%

4. And in what year were you born?

2005-1999 (18-24)	-----2%
1998-1994 (25-29)	-----4%
1993-1989 (30-34)	-----9%
1988-1984 (35-39)	-----13%
1983-1979 (40-44)	-----16%
1978-1974 (45-49)	-----12%
1973-1969 (50-54)	-----10%
1968-1964 (55-59)	-----9%
1963-1959 (60-64)	-----8%
1958-1949 (65-74)	-----12%
1948 or earlier (75+)	-----4%
(DON'T READ) Prefer not to answer	---2%

IN THIS SURVEY, WE ARE TALKING TO LOS ANGELES RESIDENTS ABOUT DIFFERENT PLACES IN THE CITY. FOR YOUR SURVEY, WE WOULD LIKE TO ASK YOU SOME QUESTIONS ABOUT GRIFFITH PARK.

5. Have you personally ever been to Griffith Park?

Yes	-----98%
No	-----1%
(DON'T READ) Don't Know/NA	-----0%

6. How familiar would you say you are with Griffith Park? Are you very familiar, somewhat familiar, not too familiar, or not familiar at all?

TOTAL FAMILIAR	-----93%
Very familiar	-----58%
Somewhat familiar	-----35%
TOTAL NOT FAMILIAR	-----7%
Not too familiar	-----6%
Not familiar at all	-----1%
(DON'T READ) DK/NA	-----0%

7. Based on what you know, do you have an overall favorable or unfavorable opinion of Griffith Park? If you do not know enough to offer an opinion, please tell me that instead. **(IF FAVORABLE/UNFAVORABLE, ASK:) "Is that very or somewhat FAVORABLE/UNFAVORABLE?"**

TOTAL FAVORABLE ----- 91%
 Very favorable ----- 59%
 Somewhat favorable ----- 32%

TOTAL UNFAVORABLE ----- 5%
 Somewhat unfavorable ----- 4%
 Very unfavorable ----- 1%

Don't know enough to offer an opinion --- 4%
(DON'T READ) DK/NA ----- 0%

(ASK Q8 IF Q5 = CODE 1 – YES, BEEN TO GRIFFITH PARK); n=4539

8. Have you visited Griffith Park in the last year, a year to two years ago, three years to five years ago, six years to 10 years ago, or more than 10 years ago?

In the last year -----71%
 A year to two years ago -----13%
 Three years to five years ago ----- 9%
 Six years to 10 years ago -----4%
 More than 10 years ago-----3%
(DON'T READ) DK/NA ----- 1%

(ASK Q9 IF Q8 = CODE 1 – BEEN TO GRIFFITH PARK IN THE LAST YEAR); n=3206

9. Approximately how many times in the last year did you visit Griffith Park: **(READ OPTIONS)**

Once a month or more -----38%
 About six to 10 times -----24%
 Two to five times-----32%
 One time-----5%
(DON'T READ) DK/NA ----- 1%

(RESUME ASKING ALL RESPONDENTS)

10. In the next year or so, how likely do you think you are to go to Griffith Park for any reason? Please use a scale of 1 to 7 where a “1” means you are not likely at all to visit Griffith Park in the next year or so and a “7” means you are very likely to visit Griffith Park in the next year or so. You can use any number from 1 to 7.

MEAN ----- 6.0
 1 (Not likely at all) -----3%
 2 -----3%
 3 -----4%
 4 -----7%
 5 ----- 11%
 6 -----9%
 7 (Very likely) ----- 60%
(DON'T READ) DK/NA ----- 3%

<p>GRIFFITH PARK IS A CITY OF LOS ANGELES PARK. IT IS LOCATED JUST WEST OF THE I-5, ROUGHLY BETWEEN LOS FELIZ BOULEVARD ON THE SOUTH AND THE 134,</p>
--

VENTURA FREEWAY, ON THE NORTH. THE PARK IS OVER 4,000 ACRES AND INCLUDES NATURAL AREAS AND LANDSCAPED PARKLAND AND PICNIC AREAS. IT IS ALSO THE LOCATION OF THE L.A. ZOO, THE GRIFFITH OBSERVATORY, THE HOLLYWOOD SIGN, THE GREEK THEATRE, AND OTHER ATTRACTIONS.

11. Now that you have heard more about it, I am going to read you some attractions and features that you may or may not have known are located in Griffith Park. After hearing each one, please tell me if you have ever visited this attraction or feature in Griffith Park. If you had never heard of an attraction or feature before I mentioned it in this survey, please tell me that instead. **(RANDOMIZE)**

	<u>YES, VISITED</u>	<u>NO, HAVE NOT VISITED</u>	<u>NEVER HEARD OF</u>	<u>(DON'T READ) DON'T KNOW</u>
[]a. Travel Town, L.A. Live Steamers, or the train rides -----	74%	22%	3%	1%
[]b. The L.A. Zoo -----	83%	16%	0%	0%
[]c. The Griffith Observatory-----	94%	5%	0%	0%
[]d. The Greek Theatre -----	79%	20%	1%	1%
[]e. The Autry Museum of the American West-----	64%	31%	4%	1%
[]f. The Griffith Park merry-go-round -----	71%	25%	3%	1%
[]g. A Griffith Park golf course or driving range -----	25%	68%	6%	1%
[]h. The L.A. Equestrian Center-----	51%	44%	4%	1%
[]i. Natural areas in Griffith Park, including picnic areas, hiking or biking trails, or gardens -----	94%	5%	0%	1%
[]j. Griffith Park playgrounds-----	72%	25%	2%	2%

12. Griffith Park previously offered pony rides in the park, but the Pony Ride was closed in December 2022. Before this survey, were you aware that pony rides were previously offered in the Park?

Yes -----91%
 No ----- 8%
(DON'T READ) DK/NA ----- 1%

(ASK Q13 IF Q12 = CODE 1 – YES, AWARE OF PONY RIDE) ; n=4188

13. Many people were not aware that the Pony Ride had been closed in Griffith Park. Before I mentioned it in this survey, were you aware the Pony Ride in Griffith Park had closed?

Yes -----85%
 No -----14%
(DON'T READ) Don't Know/NA ----- 1%

(ASK Q14 IF Q12 = CODE 1 – YES, AWARE OF PONY RIDE) ; n=4188

14. Have you or anyone in your household ever visited the Griffith Park Pony Ride, whether that was in recent years or when you were a child?

Yes -----72%
 No -----26%

(DON'T READ) DK/NA ----- 2%

(ASK Q15- Q17 IF Q14 = CODE 1 – YES, HAVE VISITED PONY RIDE) ; n=3006

15. How many times have you or someone in your household visited the Griffith Park Pony Ride? Was it just once, a few times, about half a dozen times, or more than that? Your best guess is fine.

Just once-----11%
 A few times -----26%
 About half a dozen times-----19%
 More than that -----42%
(DON'T READ) DK/NA/Refused ----- 2%

16. Was **(IF Q15= 2-5: your last visit to the Pony Ride) (IF Q14 = 1: your visit to the Pony Ride)** in the last five years or more than five years ago? Your best guess is fine.

In the last five years-----58%
 More than five years ago -----41%
(DON'T READ) DK/NA ----- 1%

17. Which of the following applies to you when thinking about the Griffith Park Pony Ride? **(PHONE: MULTIPLE RESPONSE OKAY) (RANDOMIZE CODES 1-3)**

I went to the Pony Ride when I was a child-----48%
 I took my own children to the Pony Ride -----65%
 I have been to the Pony Ride with friends or family-----61%
(DON'T READ) None (EXCLUSIVE) ----- 2%
(DON'T READ) Don't Know/NA (EXCLUSIVE) ----- 0%

(RESUME ASKING ALL RESPONDENTS)

18. The area where the Pony Ride was located is about the size of two football fields. What would you like to see in that space in Griffith Park? **(OPEN-ENDED QUESTION, MULTIPLE RESPONSE ALLOWED)**

Pony rides/bring back pony rides-----	40%
Kid's park/family friendly activities -----	12%
Parks/playground/picnic area -----	10%
Natural area/open space/greenery/plants/trees-----	7%
Gardens/botanical gardens -----	7%
Skating rink -----	6%
Museum/exhibits/nature center -----	5%
Pickleball/tennis/basketball courts -----	5%
Petting zoo -----	4%
Events/event spaces -----	4%
Waterpark/swimming/pool-----	3%
Animal sanctuary/butterflies/animals/farm animals -----	3%
Dog parks/dog walking -----	2%
Trails/hiking/biking trails/walking path -----	2%
Exercise areas/running/track -----	2%
Sports fields/areas/recreation/community center-----	2%
Restaurants/shops/farmers market -----	2%
Golfing/golf course-----	1%
Train ride expanded-----	1%
Lake/pond -----	1%
Expanded equestrian/horseback riding -----	1%
Skate park/pump track -----	1%
Low-income housing/housing -----	0%
Less homeless-----	0%
Train to take you around the park/transportation around park-----	0%
Other -----	5%
None/Nothing -----	0%
Don't Know/Unsure -----	2%
NA/Refused/No Comment -----	1%

19. Would you favor or oppose offering pony rides for children in Griffith Park again? (IF FAVOR/OPPOSE, ASK: Do you strongly (favor/oppose) it or only somewhat?)

TOTAL FAVOR ----- **55%**
 Strongly favor----- 47%
 Somewhat favor -----8%

TOTAL OPPOSE----- **38%**
 Somewhat oppose -----5%
 Strongly oppose ----- 33%

(Need more information) ----- 5%
(DK/NA) -----2%

20. Next I am going to read you a list of proposals that some people have suggested for how to use the site once occupied by the pony rides in Griffith Park. All the proposed attractions or features would be at low to no cost to park visitors. After hearing each one, please tell me how appealing the proposed feature or attraction is to you, using a scale of 1 to 7 where a “1” means it is not appealing at all and a “7” means it is very appealing. You can choose any number from 1 to 7. (RANDOMIZE)

	Not Appealing							Very Appealing (DK)		<u>MEAN</u>
	<u>1</u>	<u>2</u>	<u>3</u>	<u>4</u>	<u>5</u>	<u>6</u>	<u>7</u>	<u>8</u>		
[]a. A playground and play structures for children-----	31%	9%	10%	13%	12%	7%	18%	1%		3.6
[]b. A water play area for children with splash activities -----	30%	6%	8%	11%	10%	8%	24%	1%		3.9
[]c. Expand the park’s train rides -----	30%	8%	9%	13%	11%	7%	18%	3%		3.7
[]d. A miniature golf course -----	41%	6%	8%	11%	9%	7%	17%	1%		3.3
[]e. Sport courts and fields-----	43%	8%	8%	10%	7%	6%	16%	1%		3.1
[]f. Indoor and outdoor adventure area with activities for children and adults, such as rope courses and rock walls -----	21%	6%	8%	13%	13%	10%	28%	1%		4.4
[]g. Picnic and recreation space -----	31%	9%	9%	13%	11%	7%	18%	1%		3.6
[]h. Bring back pony rides for children-----	38%	3%	2%	3%	3%	3%	45%	2%		4.3
[]i. Interactions with horses where visitors do not ride the horses, including interactions designed to provide mental health therapy for children and adults and education about how to care for horses -----	25%	7%	8%	12%	12%	10%	24%	2%		4.1
[]j. A petting zoo -----	44%	5%	6%	9%	8%	8%	18%	1%		3.3
[]k. An indoor-outdoor museum or nature center focused on environmental science education ---	20%	6%	8%	12%	12%	10%	30%	1%		4.4

	<u>1</u>	<u>2</u>	<u>3</u>	<u>4</u>	<u>5</u>	<u>6</u>	<u>7</u>	<u>8</u>	
[]l. A community garden, including education programs on farming, growing fruit and vegetables, and farm-to-table -----	20%	7%	8%	11%	11%	9%	33%	1%	4.5

(RANDOMIZE)

[]m. Educational programs on the history of Los Angeles and Indigenous peoples -----	23%	8%	9%	14%	12%	9%	23%	1%	4.0
---	-----	----	----	-----	-----	----	-----	----	------------

(SPLIT SAMPLE A)

[]n. An animal rescue where visitors can see and learn about local native wildlife such as owls, racoons, snakes, and deer -----	17%	5%	7%	10%	12%	11%	36%	1%	4.7
---	-----	----	----	-----	-----	-----	-----	----	------------

(SPLIT SAMPLE B)

[]o. An animal rescue where visitors can see, learn about, and have limited contact with farm animals, such as cows, pigs, chickens, sheep, and goats -----	20%	5%	6%	11%	12%	11%	34%	2%	4.6
--	-----	----	----	-----	-----	-----	-----	----	------------

(RESUME ASKING EVERYONE)

(ASK Q21 ONLINE ONLY); n=4609

21. Having heard more, what would you like to see at the site of the former Pony Ride in Griffith Park—whether something you heard about in the survey or something that was not mentioned? **(OPEN-ENDED QUESTION, MULTIPLE RESPONSE ALLOWED)**

Pony rides/bring back pony rides-----	32%
Animal sanctuary/animal rescue/something with animals/ wildlife center/horse therapy -----	17%
Educational purposes/center/indigenous/nature/ environmental/science education/museum -----	16%
Sports areas/fields/courts/complex-----	11%
Activities for kids/playground-----	8%
Splash/water park/water play -----	6%
Community garden/gardening/farming education -----	6%
Petting zoo -----	5%
Recreation/picnic areas (passive park space mentions) -----	4%
Rock climbing/ropes course/adventure course -----	4%
Botanical gardens/gardens -----	3%
Miniature golf-----	3%
All interesting ideas/good ideas -----	3%
Nature areas -----	2%
Trains -----	2%
Dog park-----	1%
Walking trails -----	1%
A lake -----	0%
Eatery/restaurant/farmer’s market-----	0%
Other -----	4%
None/Nothing -----	2%
Don't Know/Unsure -----	1%
NA/Refused/No Comment -----	4%

(ASK Q22 IF CODES 3, 4, 5, OR 6—OPPOSE PONY RIDES, NEED MORE INFO, OR UNSURE—IN Q19) ; n=2085

22. Next, please tell me which of the following comes closest to your point of view when thinking about offering animal experiences at the site of the former Pony Ride in Griffith Park. **(DO NOT RANDOMIZE)**

I support offering animal experiences where visitors can interact with animals, but not ride them -----	24%
I support offering animal experiences as long as visitors cannot touch the animals-----	13%
I am opposed to any kind of animal experience at this site-----	52%
(DON'T READ) DK/NA -----	11%

Q19/Q22 COMBINED.

- Favor offering pony rides ----- 55%
- I support offering animal experiences where visitors can
interact with animals, but not ride them ----- 11%
- I support offering animal experiences as long as visitors cannot
touch the animals----- 6%
- I am opposed to any kind of animal experience at this site----- 24%
- (DON'T READ)** DK/NA ----- 5%

MY LAST QUESTIONS ARE FOR STATISTICAL PURPOSES ONLY

23. How many years have you lived in the City of Los Angeles?
- 0 to 2 years ----- 2%
 - 3 to 5 years ----- 4%
 - 6 to 10 years----- 7%
 - 11 to 19 years ----- 14%
 - 20 to 29 years ----- 17%
 - 30 or more years----- 53%
 - (DON'T READ)** DK/NA ----- 0%
 - (DON'T READ)** Refused----- 3%
24. Which of the following describes your family situation? **(READ EACH; ALLOW MULTIPLE RESPONSES FOR CODES 1 AND 2)**
- You have children under age 19-----44%
 - You have children older than age 19 -----24%
 - You do not have children-----29%
 - (DON'T READ)** DK/NA/Refused ----- 8%

(ASK Q25 IF CHILDREN UNDER 19 – CODE 1 IN Q24) ; n=2012

25. Please tell me if you have children in any of the following age groups: Newborn to two years old, three to five years old, six to 10 years old, 11 to 14 years old, or 15 to 18 years old. **(MULTIPLE RESPONSE ALLOWED)**
- Newborn to two years old-----22%
 - Three to five years old-----34%
 - Six to 10 years old -----49%
 - 11 to 14 years old -----27%
 - 15 to 18 years old -----21%
 - (DON'T READ)** DK/NA/Refused ----- 2%

(RESUME ASKING ALL RESPONDENTS)

26. Last, just to ensure that we include a wide mix of people in this survey, please stop me when I read the range that includes your household’s total annual income before taxes in 2023:

Under \$20,000 -----	3%
\$20,000 - \$40,000 -----	6%
\$40,001 - \$60,000 -----	8%
\$60,001 - \$80,000 -----	10%
\$80,001 - \$100,000 -----	11%
\$100,001 - \$150,000 -----	15%
\$150,001 or more-----	25%
(DON'T READ) Prefer not to answer -	20%

THANK YOU VERY MUCH FOR YOUR TIME AND ATTENTION TO MY QUESTIONS.

A/B SPLIT SAMPLE

Split A -----	50%
Split B -----	50%

LANGUAGE OF INTERVIEW

English (n=4,587)-----	100%
Spanish (n=22) -----	0%

Appendix L.

Historic Structures Report

March 28, 2024

Griffith Park Pony Ride Site Historic Structures Report

*Architecture
Planning
Conservation*

Griffith Park, Los Angeles, CA | March 2024



Architectural
Resources Group

Opposite page: *Pony Ride, view north, undated but likely 1950s (Los Angeles Public Library).*

CLIENT:

City of Los Angeles

Department of Recreation and Parks

PRIME:

PlaceWorks

700 S. Flower Street, Suite 600

Los Angeles, CA 90017

Addie Farrell

Principal, Environmental

Wendy Nowak

Principal, Project Manager

Asher Kaplan

Assistant Project Manager

ARCHITECT:

Architectural Resources Group, Inc.

360 E. 2nd Street, Suite 225

Los Angeles, CA 90012

Katie Horak

Principal-in-Charge

Evanne St. Charles

Project Manager

Andrew Goodrich

Architectural Historian

Sarah Devan

Architectural Conservator

Brandon Tornero

Designer

STRUCTURAL ENGINEER:

Silman

707 Wilshire Boulevard, Suite 4900

Los Angeles, CA 90017

Nathan Hicks, PE, SE

Senior Associate

Southwest Buildings Sector Manager

ARG Project #230416

Page intentionally left blank

Table of Contents

Introduction

Purpose of the Report.....	1
Preservation Objectives.....	2
Methodology.....	2

Part I: Developmental History

Historical Background and Context.....	4
Chronology of Development and Use.....	10
Physical Description.....	17
Evaluation of Significance.....	37
Existing Conditions Assessment.....	43

Part II: Treatment and Work Recommendations

Historic Preservation Objectives.....	71
Treatment Recommendations.....	73

Bibliography

Bibliography.....	79
-------------------	----

Appendices

Appendix A: Structural Report

Appendix B: Existing Conditions Drawings

Appendix C: Historic Drawings

Appendix D: Contributing and Non-Contributing Resource Maps

Introduction

Purpose of the Report

At the request of the City of Los Angeles Department of Recreation and Parks (RAP), Architectural Resources Group (ARG) has prepared this Historic Structures Report (HSR) for the Griffith Park Pony Ride Site, located at 4400 Crystal Springs Drive in Griffith Park, Los Angeles, California.

An HSR is a well-defined technical document that is used to inform the condition and future treatment of a historic property, as described by the National Park Service (NPS) in *NPS Preservation Brief 43: The Preparation and Use of Historic Structure Reports*, and by the California Office of Historic Preservation (OHP)'s recommended "Historic Structure Report Format".¹ ARG developed the HSR for the Griffith Park Pony Ride Site in accordance with these federal and state guidelines. The purpose of this HSR is to document the Pony Ride Site's history, significance, and existing conditions, and to appropriately guide the consideration and evaluation of potential future use options.

An HSR establishes a valuable foundation for the rehabilitation of historic properties. It is a technical planning tool that will assist in directing the future of the Pony Ride facility and grounds in a manner that retains significant features, materials, and spatial relationships to the extent feasible. The prevailing goals of this document are to provide a clear understanding of the Pony Ride's significance and condition, to establish a basic framework for decision making for use by current and future stewards of the facility, and to provide treatment priorities for future rehabilitation, restoration, and maintenance.

The Griffith Park Pony Ride Site opened in 1947 and is significant for its association with the early post-World War II expansion of the City of Los Angeles's recreational offerings at Griffith Park. The Pony Ride was a popular local attraction, enjoyed by generations of Angelenos until the facility closed in 2022. The site is currently vacant, and RAP is exploring options for its future use.

Griffith Park, in its entirety, was designated Los Angeles Historic-Cultural Monument (HCM) No. 942 in 2009, and as part of this designation the Pony Ride Site was listed as a contributing feature of the HCM.²

¹ Deborah Slaton, National Park Service, *Preservation Brief 43: The Preparation and Use of Historic Structure Reports*, April 2005; California Office of Historic Preservation, "Historic Structure Report Format," February 2003.

² Refer to the Evaluation of Significance section under Part 1: Developmental History for an overview of the historical significance of Griffith Park and the Pony Ride Site.

Preservation Objectives

According to *Preservation Brief 43: The Preparation and Use of Historic Structure Reports*, an HSR provides documentary, graphic, and physical information about a property's history and existing conditions. Broadly recognized as an effective part of preservation planning, an HSR also provides a thoughtfully considered argument for selecting the most appropriate approach to treatment prior to the commencement of work. An HSR serves as an important guide for all changes made to a historic property and outlines a scope of recommended work.

This HSR is intended to provide recommendations to assist in guiding the rehabilitation, restoration, and maintenance of the Pony Ride facility and grounds.

Methodology

This HSR has been developed using information gathered through background document review, primary and secondary source research, and field investigation. The methodology that was employed for this report ascribes to the guidelines, standards, and best professional practices that are enumerated in the following reference materials:

- *Preservation Brief 43: The Preparation and Use of Historic Structure Reports*
- *The Secretary of the Interior's Standards for the Treatment of Historic Properties with Guidelines for Preserving, Rehabilitating, Restoring, and Reconstructing Historic Buildings*
- *National Register Bulletin 39: Researching a Historic Property*

The report conveys information about the subject property in two parts: 1) Developmental History and 2) Treatment and Work Recommendations.

Part 1, Developmental History, comprises a historical background and context; a chronology of development and use; a physical description and list of character-defining features; and a summary of significance. Part 1 also provides an analysis of the existing conditions of the Pony Ride buildings and structures.

Part 2 provides a comprehensive set of treatment and use recommendations for the facility, including the conservation of significant materials. The proposed treatment was developed in accordance with *The Secretary of the Interior's Standards for the Treatment of Historic Properties with Guidelines for Preserving, Rehabilitating, Restoring, and Reconstructing Historic Buildings*.

Conditions Assessment and Document Review

ARG conducted a site visit on June 26, 2023, along with representatives from Silman, structural engineers, and Department of Recreation and Parks staff. The conditions of the buildings, structures, and surrounding site were examined and documented with digital photographs and field measurements.

Research

ARG reviewed primary and secondary source materials related to the history and development of the Pony Ride. Sources included historic drawings and photographs; historic building permits available online through the City of Los Angeles Department of Building and Safety web portal; reference materials from the Los Angeles Public Library; various online repositories; and the Griffith Park HCM nomination. These materials aided in the preparation of the Developmental History section of this report.

Part I: Developmental History

Historical Background and Context

Early History and Establishment of Griffith Park

The land that would become Griffith Park was originally inhabited by the Gabrielino-Tongva people. The Gabrielino-Tongva are believed to have arrived in the Los Angeles Basin approximately 7,000 years ago.³ Their traditional territory included the majority of Los Angeles County, the northern portion of Orange County, the western sections of San Bernardino and Riverside Counties, and the southern Channel Islands.⁴ The Gabrielino-Tongva were hunter-gatherers and inhabited permanent settlements located near stable food and water supplies. Prior to European contact, their population numbered around 5,000, and they occupied nearly 100 villages throughout the region. Villages were reportedly most abundant in the San Fernando Valley, the Glendale Narrows area north of downtown, and land surrounding the Los Angeles River's coastal outlets. Sources indicate that the Gabrielino-Tongva village of Maungna (or Maawnga) encompassed the land that later fell within Rancho De Los Feliz, a portion of which now comprises Griffith Park.⁵ While the Gabrielino-Tongva's first contact with European settlers occurred in the mid-1500s, it was not until the 1770s that the area was explored by the Spanish in earnest. The impact of the Spanish mission system on California's indigenous population was devastating. The Gabrielino-Tongva and other coastal tribes were forced to re-settle around the missions in filthy, disease-ridden, and overcrowded labor camps. Roughly one third of the state's indigenous population died as a direct consequence of the mission system and forever changed California native cultures.⁶

The land encompassing Griffith Park was historically part of Rancho Los Feliz, a 6,647-acre land grant that the Spanish Crown had gifted retired corporal Jose Vicente Feliz sometime between 1795 and 1800. The earliest extant building in the park is an adobe residence built in the 1830s by Feliz's son, Jose Paco Feliz. The rancho changed hands several times over the next several decades. In 1882, then-rancho owner Thomas Bell sold 4,071 acres of the property to Colonel Griffith J. Griffith.⁷

Fueled by a fare war between the major transcontinental railroad companies, Los Angeles experienced a tremendous population influx in the late 19th century, from 11,183 residents in 1880 to 50,395 in 1890. This population increase subsequently led to a real estate boom that lasted until 1888. During the boom years,

³ "History," *Gabrielino-Tongva Indian Tribe*, accessed August 2023, <https://gabrielinotribe.org/history/>.

⁴ Sean Greene and Thomas Curwen, "Mapping the Tongva Villages of L.A.'s Past," *Los Angeles Times*, accessed August 2023, <https://www.latimes.com/projects/la-me-tongva-map/>.

⁵ ESA, "Silver Lake Reservoir Complex Master Plan Project: Draft Environmental Impact Report," prepared for City of Los Angeles Bureau of Engineering, Department of Public Works, October 2022, 3.17-2 to 3.17-3.

⁶ Edward D. Castillo, "Short Overview of California Indian History," *State of California Native American Heritage Commission*, accessed August 2023, <https://nahc.ca.gov/resources/california-indian-history/#:~:text=About%20100%2C000%20or%20nearly%20a,managed%20to%20maintain%20tribal%20cohesion.>

⁷ ICF Jones & Stokes, Los Angeles Historic-Cultural Monument Application, "Griffith Park," 2008, 6.

Griffith made a sizable profit selling off portions of the former rancho for housing development, including land now comprising residential neighborhoods in present-day Los Feliz and Silver Lake. However, Griffith was also a proponent of the ideals set forth by the City Beautiful Movement, including the philosophy that the creation of parks, green space, and other forms of leisure and recreation were critical to the health and well-being of a city's residential population. Correctly predicting that Los Angeles would one day be a vast metropolis, Griffith made plans to set aside a large portion of his rancho landholdings for use as a public park.⁸ In December 1896, Colonel Griffith and his wife, Mary Agnes Christina (Tina) Griffith, announced their intention to donate 3,015 acres of the rancho to the City of Los Angeles to be made available as a city park.⁹ The donation was particularly momentous in the city's history, not solely because of the park land, but primarily for the free and clear water rights that came with it—water rights that would contribute to the city's growth and development during the late 19th and early 20th centuries.¹⁰ Official transfer of ownership was completed in 1898. In addition to mandating that the land always be used as a public park, Griffith required that the property always be known as Griffith Park.¹¹

Early 20th Century Development of Griffith Park

Since its founding, Griffith Park has been a site for recreation, with early forms including horseback riding and hiking. One of the first park trails to be constructed by the City was a footpath up to Mt. Hollywood, the highest peak in the park (built 1909). In the 1910s and 1920s, new recreational amenities were introduced in the park. These recreational offerings “marked a new manner of experiencing the park: away from simple being-in the rustic landscapes of the City Beautiful movement and toward pro-active physical activities.”¹² Among these amenities were the Riverside Golf Course (later renamed the Warren G. Harding Golf Course), the park's first municipal golf course (developed in 1900 and improved in 1914); the Wilson Golf Course (built 1923); the development of boys and girls overnight camps (added 1926); the construction of a municipal plunge facility, which included recreational courts and fields, horseshoe pits, a playground, and a pool (built 1927); and the construction of new hiking and equestrian trails throughout the park.¹³

Following Colonel Griffith's death in 1919, Van Griffith, his only son, assumed the role of park developer. The younger Griffith continued to carry out his father's original vision for the park, “seeking new ways to expand the park's offerings to the public while preserving open space.”¹⁴ Among Van Griffith's notable contributions to the park include the creation of its first irrigation system and the construction of a municipal nursery, which raised plants for reforestation efforts in the park.¹⁵

⁸ Ibid, 11-12.

⁹ Additional surrounding land was donated as well as acquired by the city since the park's initial founding, and today the park encompasses 4,210 acres.

¹⁰ ICF Jones & Stokes, “Griffith Park,” 6-10.

¹¹ Ibid, 10.

¹² Ibid, 16.

¹³ Ibid, 15-16, 19.

¹⁴ Ibid, 23.

¹⁵ Ibid.

Griffith Park witnessed a period of increased development and use in the 1930s and 1940s. Early in the Great Depression, the City passed a \$5 million unemployment relief bond measure, which included \$1 million for the parks. Through this bond measure, Griffith Park received new bridle trails, new and improved picnic areas, and expanded automobile parking. Federal assistance programs also helped to further develop the park during this period. Federally funded projects included trail and road improvements, weed clearing, planting, and construction of recreational fields by the Reconstruction Finance Corporation (RFC); construction of the Roosevelt Golf Course (relocated to the southeast portion of the park in the 1960s to make way for the new zoo), flood control improvements, and expansion of the zoo (first opened in 1912) by the Works Progress Administration (WPA); and firebreak clearance, pool upgrades, and development of new trails, roads, picnic areas, and campgrounds by the Civilian Conservation Corps (CCC).¹⁶ The 1930s also represented the development of two of the park's most iconic projects—the Greek Theatre (completed 1930) and Griffith Observatory (completed 1935). While less iconic, the park's Merry-Go-Round was also installed during this period and represented a reasonably inexpensive form of amusement for Depression-era parents and children.¹⁷

With the beginning of America's involvement in World War II, Griffith Park became a major destination for Angelenos. Due to gasoline rationing during wartime, longer trips to the beach or the mountains were cost prohibitive to many residents, and the park represented a close-by recreation alternative.¹⁸ The park served other purposes beyond recreation during the war, including strength training exercises and swim lessons for servicemen at the pool and in various locations throughout the park; a Prisoner of War (POW) camp for Japanese, German, and Italian prisoners established near of the current location of Travel Town; and Red Cross convalescent hospitals set up at the Greek Theatre and Griffith Observatory. Immediately following the war, Rodger Young Village, a temporary residential neighborhood comprising 1,500 Quonset huts, was built to alleviate the housing shortage resulting from returning GIs.¹⁹

Park Development in the Immediate Post-World War II Period

While recreational amenities had existed at Griffith Park since the early 1900s development of the Riverside Golf Course, the park experienced an even greater expansion of recreational offerings in the postwar period. As described by author Mike Eberts:

By the time World War II ended, the notion that urban parks should be quiet, sylvan sanctuaries of meandering walkways, expansive lawns and secluded benches had undergone substantial revision. Recreation—playgrounds, athletic fields and organized attractions—had become an increasing part of what parks were supposed to be about.²⁰

¹⁶ Ibid, 28-31.

¹⁷ Ibid, 32-34.

¹⁸ Ibid, 36.

¹⁹ Ibid, 37.

²⁰ Mike Eberts, *Griffith Park: A Centennial History* (Los Angeles: Historical Society of Southern California, 1996): 265.

Following the war, the Park Department and Playground Department merged to form the Recreation and Parks Department. Headed by General Manager George Hjelte, who had a background in recreation, the newly formed department was charged with the development of new and expanded recreational opportunities at Griffith Park.²¹ Early postwar recreational amenities included the Griffith Park Pony Ride Site (developed 1947); a nine-hole pitch-and-putt course called the Coolidge Golf Course (now the Marty Tregnan Golf Academy; built 1947); a miniature train ride named the Griffith Park and Southern Railroad (added 1947); and the Travel Town Transportation Museum, a vast collection of early locomotives and an old Southern Pacific Railroad depot (developed 1952).²²

Griffith Park underwent a few significant changes in the late 1950s and early 1960s. In 1957, the Interstate 5 freeway was completed along the eastern edge of the park, severing the park's historic relationship with the Los Angeles River. Construction of Interstate 5 was soon followed by the development of State Route 134 along the northern boundary of the park in the 1960s. In 1958, Toyon Canyon, located in the northern section of the park, was developed as a landfill, handling much of the city's municipal waste.²³ These events signified the mounting pressures the city's postwar growth and expansion had placed on its largest public open space. It also represented a shift in park planning and development.

The mid-1960s brought additional, significant changes to the park, including development of the new 133-acre zoo (1966) and the construction of the new nine-hole Roosevelt Municipal Golf Course (1966). According to the 1968 Griffith Park Master Plan, the City had a responsibility to develop the park to "its fullest potential" including the construction a several large new roads, parking lots, golf courses, and overnight camping facilities.²⁴ However, these ambitious plans were relatively short-lived. In 1978, a revised master plan was created, which provided for a more ecologically and preservation-minded approach to the park's management, in keeping with Colonel Griffith's original goals for the park.²⁵ There have been a few smaller changes to the park since the late 1970s, including the construction of the Autry National Center (1987) as well as smaller park buildings and structures such as the Marty Tregnan Golf Academy building (2000).

Development of the Griffith Park Pony Ride Site

The origins of the Griffith Park Pony Ride Site date to the late 1930s when Thomas Wright and his wife Hazel began operating a pony ride at Lincoln Park.²⁶ In 1946, it was announced that a new pony ride facility would be constructed in Griffith Park, adjacent to the proposed miniature train ride.²⁷ Plans for the new facility were prepared by the Department of Parks in May 1946, and the Wrights relocated their pony ride operation to Griffith Park by 1947. The original development included a pergola shelter, a riding ring with walking, trotting,

²¹ Eberts, 265.

²² ICF Jones & Stokes, "Griffith Park," 37-39.

²³ The landfill ceased operation in 1985 and fully closed in 2008.

²⁴ Los Angeles Department of Recreation and Parks, Griffith Park Master Plan, 1968.

²⁵ Eberts, 329.

²⁶ "Former Fairburians Have World's Largest Pony Ride Concession," *Fairbury Journal-News* (Fairbury, NE), March 11, 1954.

²⁷ "Park Board Gets Sketches of Proposed Griffith Park Railway," *Los Angeles Evening Citizen News*, December 28, 1946.

running, and buggy ride tracks, and a 30'-diameter pony sweep, located to the north of the pergola and ring (not extant).²⁸ The ticket booth was installed by 1952.²⁹ From its inception, the Pony Ride Site was well received by Angelenos, appealing especially to families with young children. A 1953 *Los Angeles Mirror* article deemed the Pony Ride Site a “mecca for the hundreds of small fry who visit the park with their parents,” many of whom had little to no prior equestrian experience growing up in Los Angeles’ urban environment.³⁰ In its first few years of operation, the Wrights hired a dozen employees to keep up with the attraction’s expanding demand. Among them was their daughter Joyce who helped sell tickets and saddle children, as well as eight high school boys and three men who kept the ponies and maintained the grounds. Since moving from Lincoln Park to the new Griffith Park site, the Wrights had become the second largest breeders of Shetland ponies in California. By the mid-1950s, the Griffith Park Pony Ride was purportedly the largest pony ride concession in the world, with 92 ponies giving approximately 3,000 kids a ride on any given Sunday.³¹

The Pony Ride experienced a number of changes beginning in the late 1950s through the mid-1960s. In 1957, the City’s Board of Recreation and Park Commission approved the extension of Thomas Wright’s contract to operate the lucrative Pony Ride concession for three more years.³² That same year, Interstate 5 was constructed directly east of the facility. While the buildings and structures within the Pony Ride area were not impacted by the construction, a road accessing the grounds from Riverside Drive was demolished, and the open space to the south and east of the developed area, the current location of the barn and corrals, was reconfigured. A paved parking lot was also added around this time, north of the facility, and a new vehicular/maintenance drive (leading to the barn and corral area) was constructed, resulting in the removal of an original grass training ring south of the miniature train tracks.³³ Additional changes during this time period included the construction of a snack stand with restrooms in 1960, and the construction of a new barn and corrals between 1964 and 1965.³⁴

In 1979, the Department of Recreation and Parks issued a request for bids for the Pony Ride concession contract, which was re-awarded to Thomas Wright.³⁵ Under the terms of the ten-year contract, the owner

²⁸ Department of Parks, City of Los Angeles, Board of Park Commissioners, “Plot Plan of Pony Ride,” May 3, 1946. Based on aerial photographs, the existing pony sweep was added between 1989 and 2003.

²⁹ Aerial photograph, 1952, “Frame Finder,” Special Research Collections, UCSB Library, University of California Santa Barbara, accessed August 2023, https://mil.library.ucsb.edu/ap_indexes/FrameFinder/.

³⁰ “Small Fry Find ‘Old West’ Still Lives,” *Los Angeles Mirror*, June 25, 1953.

³¹ “Take a Peek, Fellers, That New Pony’s Here,” *Los Angeles Mirror*, November 16, 1949; “Former Fairburians Have World’s Largest Pony Ride Concession;” “Small Fry Find ‘Old West’ Still Lives,” .

³² “Pony Ride Concession,” *Los Angeles Evening Citizen News*, August 9, 1957.

³³ Aerial photographs, 1952 and 1960, “Frame Finder,” Special Research Collections, UCSB Library, University of California Santa Barbara, accessed August 2023, https://mil.library.ucsb.edu/ap_indexes/FrameFinder/; Department of Recreation and Parks, Planning and Engineering Division, City of Los Angeles, California, “Roadway to Pony Stables: Pony Ride Area, Griffith Park,” September 1957.

³⁴ “Griffith Construction Contract Awarded,” *Los Angeles Evening Citizen News*, August 2, 1960; Aerial photographs, 1964 and 1965, “Frame Finder,” Special Research Collections, UCSB Library, University of California Santa Barbara, accessed August 2023, https://mil.library.ucsb.edu/ap_indexes/FrameFinder/ and “Historic Aerials,” *NETRONLINE*, accessed August 2023, <https://historicaerials.com/>.

³⁵ “Bids Wanted,” *Los Angeles Times*, March 5, 1978; Board of Recreation and Park Commissioners, “Griffith Park Pony Ride Concession Request for Proposals.”

was responsible for various facilities improvements, including repairing the Site's picket fences and posts, adding metal water trough covers and support posts, fortifying and painting the pergola's support posts, and other minimal routine updates to the riding ring, barn, and corrals (i.e. resealing open joints and tightening loose hinges where necessary).³⁶ However in 1980, just one year after obtaining the new concession contract, Wright developed health problems and requested a transfer of contract to his longtime colleague, Hank Williams Bronk. After immigrating to Los Angeles from the Netherlands in 1955, Bronk worked alongside Wright raising ponies and operating the Pony Ride concession for over 15 years. The Board of Recreation and Park Commission approved the contract transfer, and Bronk acquired the property in July 1980, thus ending Wright's three-decade tenure as concessioner.³⁷

By the mid-1980s, Bronk had expanded the Pony Ride operation to include over 100 Shetland and Welsh ponies.³⁸ But despite its continued popularity, the concession attraction suddenly faced the threat of closure in 1986 after abruptly losing its insurance liability coverage.³⁹ Los Angeles Mayor Tom Bradley was among the advocates who expressed support for the Park's pony attraction, stating that:

...the problems of obtaining affordable liability coverage for local governments and municipal services has reached a critical stage for many cities, but never did I think that the children of Los Angeles and surrounding areas would have to bear the ultimate sacrifice of losing the park pony rides forever because an insurance carrier can't be found to offer an adequate policy.⁴⁰

The Pony Ride concession was rescued later that year after the Board of Recreation and Park Commissioners unanimously voted to allow the City of Los Angeles to create a payout fund that would cover and settle future claims against the business.⁴¹ Bronk and his family operated the Pony Ride until 2016 and do not appear to have made any substantial changes to the facility.⁴²

In 2016, Los Angeles Pony Rides, Inc., led by Steve Weeks, was awarded the concessioner contract for the facility. Under the contract agreement, the concessioner was required to make several improvements, including repair/replacement of water troughs, repair of concrete flooring and footings at the pergola,

³⁶ Board of Recreation and Park Commissioners, "Concession Agreement Between the City of Los Angeles and Thomas T. Wright," June 28, 1979, 11-12. It is unknown whether Wright made any of the improvements listed in the contract agreement, however it is likely the improvements were completed incrementally during the tenure of his successor Hank William Brock, who obtained the concession contract just one year later.

³⁷ Board of Recreation and Park Commissioners, "Griffith Park Pony Ride Concession Request for Proposals;" Board of Recreation and Park Commissioners, "Griffith Park Pony Ride Concession – Award of Contract to Los Angeles Pony Rides, Inc., Authorization to Develop Concession Agreement," Board Report No. 16-108, May 4, 2016; Board of Recreation and Park Commissioners, "Griffith Park Pony Ride Concession – Assignment of Contract," Board Report No. 233-80, March 20, 1980; Board of Recreation and Park Commissioners, "Assignment of Concession Agreement," July 24, 1980; "Pony Ride Robber Escapes with \$5,000," *Los Angeles Times*, July 16, 1991.

³⁸ "Ponies in Peril: Insurance Woes Threaten Griffith Park Ride," *Los Angeles Times*, February 11, 1986.

³⁹ "Save the Pony Rides," *Los Angeles Times*, February 12, 1986; "Ponies in Peril: Insurance Woes Threaten Griffith Park Ride."

⁴⁰ "Mayor Tom Bradley," *Los Angeles Times*, February 14, 1986.

⁴¹ "Griffith Park Pony Ride Escapes Last Roundup," *Los Angeles Times*, February 15, 1986.

⁴² Board of Recreation and Park Commissioners, "Griffith Park Pony Ride Concession Request for Proposals;" Board of Recreation and Park Commissioners, "Griffith Park Pony Ride Concession – Award of Contract to Los Angeles Pony Rides, Inc., Authorization to Develop Concession Agreement," Board Report No. 16-108, May 4, 2016.

repair/replacement of the barn’s roof and gutters, repainting of the ticket office, pergola, fence, and barn, and new landscaping in the pony corrals.⁴³ The concessioner proposed several other modifications, including remodeling the ticket office, adding a petting zoo and a sales kiosk, constructing a birthday pavilion, installing artificial turf in the pony ring, and installing a video security system. Total improvements were expected to cost \$83,000.⁴⁴ While the artificial turf, sales kiosk, and video security system do not appear to have been added, the birthday pavilion (“Oak Grove” birthday pavilion) was added in 2016.⁴⁵ A second birthday pavilion (“Coyote Meadow” birthday pavilion), located west of the riding ring, was installed between 2018 and 2019.⁴⁶ The petting zoo feature was added at some point during Weeks’ tenure as well. In 2022, the Department of Recreation and Parks chose not to renew the concessioner contract, and the Griffith Park Pony Ride ceased operation.⁴⁷

Chronology of Development and Use

- 1946: Plans were announced for the construction of a pony ride at the southeast end of Griffith Park.⁴⁸ Drawings prepared by the Department of Parks indicated the new development would include a pergola shelter, a riding ring with walking, trotting, running, and buggy ride tracks, and a 30’-diameter pony sweep (sweep not extant).⁴⁹
- 1947: Thomas Wright and his wife, Hazel, moved their pony ride operation from Lincoln Park to the new facility in Griffith Park. The Wrights operated the Griffith Park Pony Ride until 1980.⁵⁰
- 1947-52: Based on historic drawings and aerial photographs, the ticket booth was added between 1947 and 1952.⁵¹

⁴³ Agreement for the Operation and Maintenance of the Griffith Park Pony Ride Concession between the City of Los Angeles Department of Recreation and Park and Los Angeles Pony Rides, Inc., 2016.

⁴⁴ Board of Recreation and Park Commissioners, “Griffith Park Pony Ride Concession – Award of Contract to Los Angeles Pony Rides, Inc., Authorization to Develop Concession Agreement.”

⁴⁵ Board of Recreation and Park Commissioners, “Griffith Park Pony Ride Concession – Proposal by Los Angeles Pony Rides, Inc. for the Construction of a Birthday Part Pavilion – Exemption from the California Environmental Quality Act (CEQA) Pursuant to Article III, Section 1, Class 3(3) and Class 11(6) of the City CEQA Guidelines,” Board Report No. 16-254, December 14, 2016.

⁴⁶ Aerial photographs, Google Earth, 2018 and 2019, “Google Earth Pro,” accessed August 2023, <https://earth.google.com>.

⁴⁷ Laura Newberry, “Long-running Griffith Park Pony Rides to Close this Year,” *Los Angeles Times*, December 5, 2022.

⁴⁸ “Park Board Gets Sketches of Proposed Griffith Park Railway.”

⁴⁹ Department of Parks, City of Los Angeles, Board of Park Commissioners, “Plot Plan of Pony Ride;” Per a 1956 site plan, a new pony sweep appears to have been added just east of the pergola, in the approximate location of the existing sweep, by 1956. This sweep was removed by 1977. The existing pony sweep was added between 1989 and 2003.

⁵⁰ Board of Recreation and Park Commissioners, “Griffith Park Pony Ride Concession – Award of Contract to Los Angeles Pony Rides, Inc. (CON-M16-001),” Board Report No. 16-147, July 13, 2016.

⁵¹ Department of Parks, City of Los Angeles, Board of Park Commissioners, “Plot Plan of Pony Ride;” aerial photograph, 1952, “Frame Finder,” Special Research Collections, UCSB Library, University of California Santa Barbara, accessed August 2023, https://mil.library.ucsb.edu/ap_indexes/FrameFinder/.

- 1954: By the mid-1950s, the Griffith Park Pony Ride was considered the largest pony ride concession in the world, with 92 ponies giving approximately 3,000 kids a ride on any given Sunday.⁵²
- 1957: Thomas Wright was awarded a three-year contract expansion as concessioner of the Pony Ride Site.⁵³
- The Interstate 5 freeway was completed just east of the Pony Ride Site. While the developed portion of the facility was not impacted by the freeway construction, a road that connected the Pony Ride Site to Riverside Drive was demolished, and the open space to the south and east of the facility was reconfigured. The parking lot to the north of the site was likely added during this time.⁵⁴
- A vehicular/maintenance drive was added, leading from Crystal Springs Drive to the barn and corral area, resulting in the removal of a grass training ring to the south of the miniature train tracks.⁵⁵
- 1960: The City Recreation and Park Commission awarded a \$38,263 contract for the construction of a concession building and sanitary facility (snack stand and restroom) at the Pony Ride Site to John Hofius of El Monte. The building was to be 46' wide by 48' long and made of concrete block with a steel roof.⁵⁶ Paving around the snack stand appears to have been added at this time.
- 1964-65: Per historic aerial photographs, the barn was built southeast of the pergola, ticket booth, and riding ring.⁵⁷
- 1980: The concessioner contract was transferred to Hank William Bronk. Bronk and his family operated the Pony Ride until 2016. With the exception of adding a new pony sweep (see below), no substantial improvements appear to have been made to the facility under Bronk's ownership.⁵⁸

⁵² Ibid.

⁵³ "Pony Ride Concession."

⁵⁴ Aerial photographs, 1952 and 1960, "Frame Finder," Special Research Collections, UCSB Library, University of California Santa Barbara, accessed August 2023, https://mil.library.ucsb.edu/ap_indexes/FrameFinder/.

⁵⁵ Department of Recreation and Parks, Planning and Engineering Division, City of Los Angeles, California, "Roadway to Pony Stables: Pony Ride Area, Griffith Park," September 1957.

⁵⁶ "Griffith Construction Contract Awarded."

⁵⁷ Aerial photographs, 1964 and 1965, "Frame Finder," Special Research Collections, UCSB Library, University of California Santa Barbara, accessed August 2023, https://mil.library.ucsb.edu/ap_indexes/FrameFinder/.

⁵⁸ Board of Recreation and Park Commissioners, "Griffith Park Pony Ride Concession Request for Proposals," Report of General Manager No. 05-174, June 15, 2005; Board of Recreation and Park Commissioners, "Griffith Park Pony Ride Concession – Award of Contract to Los Angeles Pony Rides, Inc., Authorization to Develop Concession Agreement."

- 1986 Bronk had expanded the Pony Ride operation to include over 100 Shetland and Welsh ponies.⁵⁹
- The Pony Ride Site faced the threat of closure as a result of Bronk’s sudden loss of liability insurance coverage but was subsequently saved by an insurance agreement after the Board of Recreation and Park Commissioners unanimously voted to allow the City of Los Angeles to create a payout fund that would cover and settle future claims against the business.⁶⁰
- 1989-2003: Based on aerial photographs, the existing pony sweep appears to have been added between 1989 and 2003.⁶¹
- 2016: A new concessioner contract was awarded to Los Angeles Pony Rides, Inc., led by Steve Weeks. Under the contract agreement, the concessioner was required to make several improvements to the facility, including repair/replacement of water troughs, repair of concrete flooring and footings at the pergola, repair/replacement of the barn’s roof and gutters, repainting of the ticket office, pergola, fence, and barn, and new landscaping in the pony corrals.⁶²
- The Recreation and Park Commission approved of the construction of a birthday pavilion (“Oak Grove” birthday pavilion, built south of the riding ring).⁶³
- 2018-19: Per aerial photographs, a second birthday pavilion (“Coyote Meadow” birthday pavilion), located west of the riding ring, was added between 2018 and 2019.⁶⁴
- 2022: The Department of Recreation and Parks chose to not renew the Pony Ride concessioner contract, and the facility closed to the public.⁶⁵
- Dates unk. Chain-link fencing was added around the riding ring.
- A wood structure was added around the light pole in the riding ring, sometime after 1991.
- A petting zoo attraction was added sometime after 2016.
- Wood fencing and guide rails have been replaced in the riding ring, likely multiple times over the years.

⁵⁹ “Ponies in Peril: Insurance Woes Threaten Griffith Park Ride.”

⁶⁰ “Griffith Park Pony Ride Escapes Last Roundup.”

⁶¹ Aerial photographs, 1989, 1994 and 2003, “Google Earth Pro,” accessed August 2023, <https://earth.google.com>. Based on historic aerials and a 1956 site plan, the existing sweep was built in the location of an older sweep that had been removed by 1977.

⁶² Agreement for the Operation and Maintenance of the Griffith Park Pony Ride Concession between the City of Los Angeles Department of Recreation and Park and Los Angeles Pony Rides, Inc., 2016.

⁶³ Board of Recreation and Park Commissioners, “Griffith Park Pony Ride Concession – Proposal by Los Angeles Pony Rides, Inc. for the Construction of a Birthday Part Pavilion – Exemption from the California Environmental Quality Act (CEQA) Pursuant to Article III, Section 1, Class 3(3) and Class 11(6) of the City CEQA Guidelines.”

⁶⁴ Aerial photographs, 2018 and 2019, “Google Earth Pro,” accessed August 2023, <https://earth.google.com>.

⁶⁵ Newberry, “Long-running Griffith Park Pony Rides to Close this Year.”

Shade structures were added in the riding ring.

Stanchions, a shade structure, and various conduits were added to the pergola.

New trees have been added to the site over the years. Some species include carrotwood, gold medallion, palm, and jacaranda. Other species such as sycamore and elderberry were removed from the site (see 1956 “Griffith Park Pony Ride Area” site plan, in Appendix C: Historic Drawings).

Historic Photographs and Drawings⁶⁶

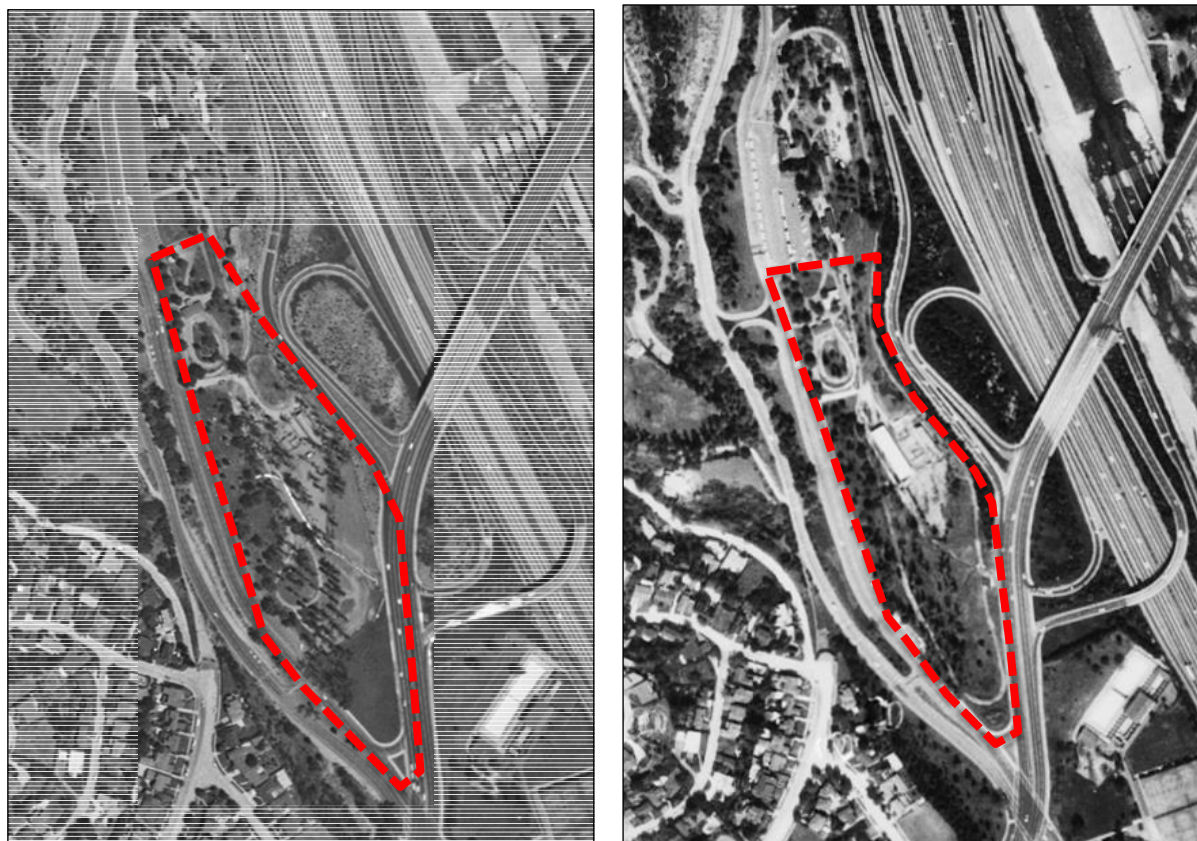

Aerial views of the Pony Ride Site (outline in dashed red line), 1960 (left) and 1965 (right). Note presence of barn and corrals in the right image (UCSB Frame Finder).

⁶⁶ Refer to Appendix C for larger copies of the historic drawings.

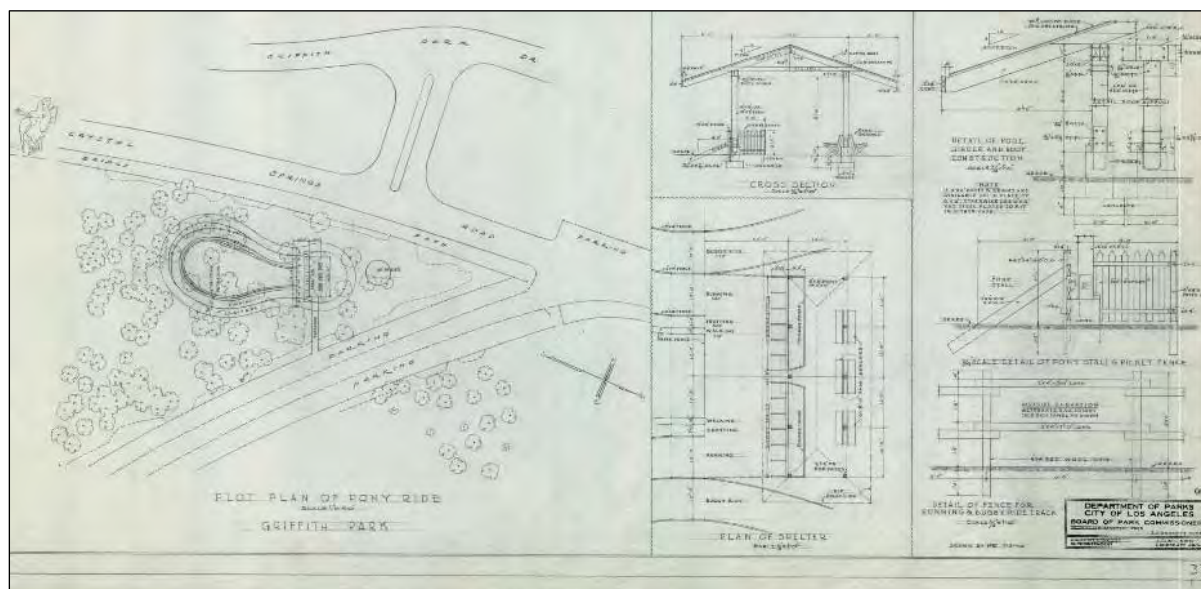

Griffith Park Pony Ride Plot Plan and plan, section, and details of pergola, 1947 (Department of Parks, City of Los Angeles, Board of Park Commissioners).

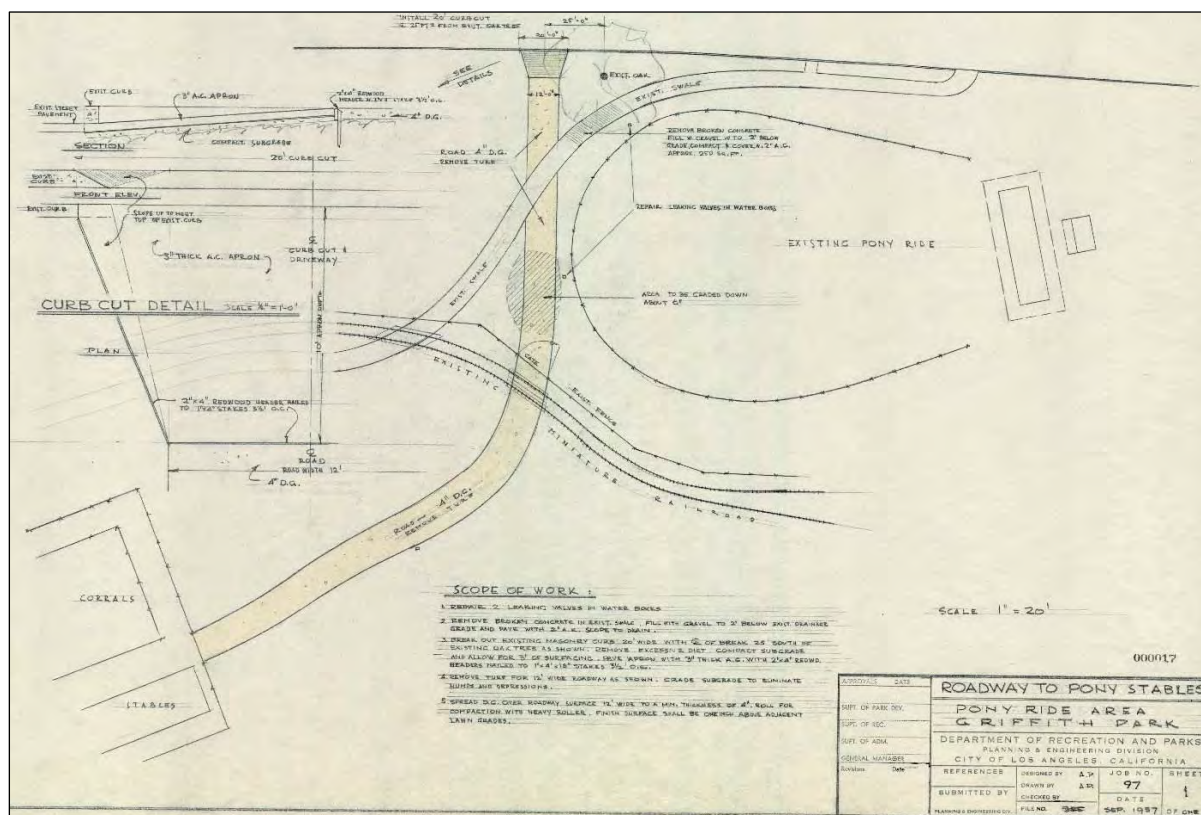

Roadway to Pony Stables: Pony Ride Area, 1957 (Department of Recreation and Parks).

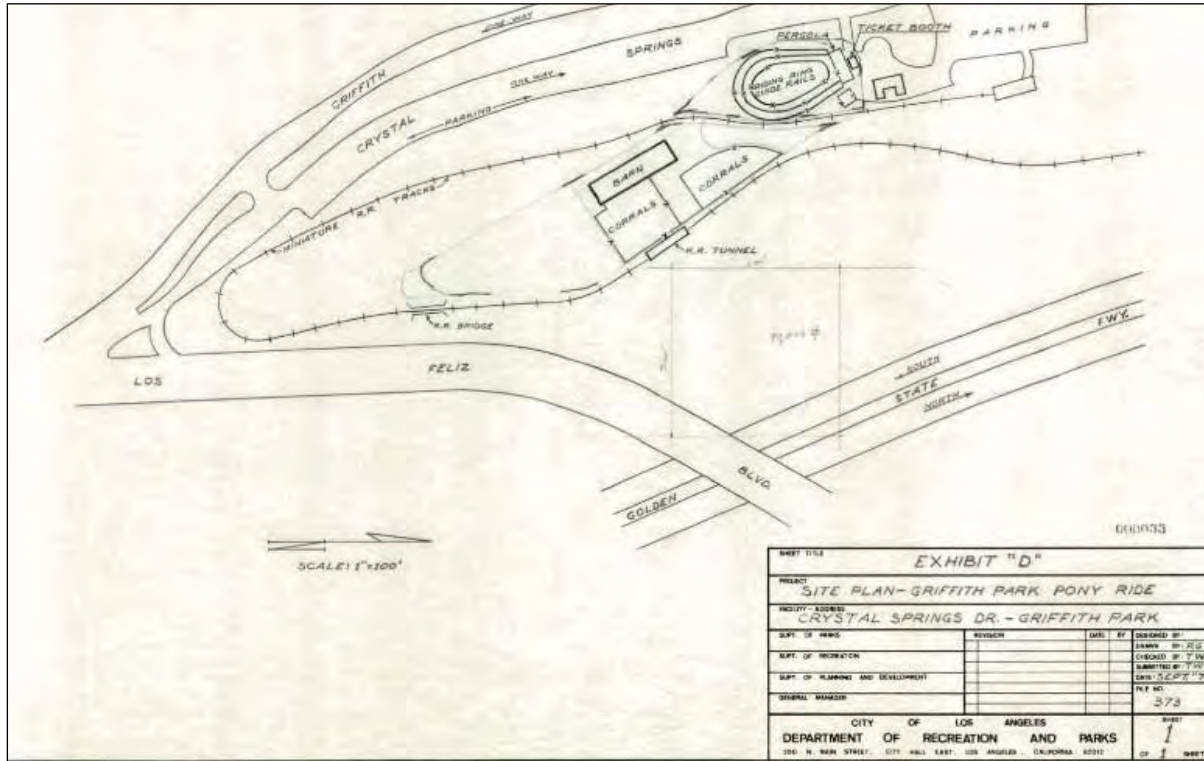

Griffith Park Pony Ride Site Plan, 1977 (Los Angeles Department of Recreation and Parks).



Pony Ride pergola and riding ring, no date but likely 1950s. Note configuration of historic fencing and presence of light pole without look-out structure at the base (Los Angeles Public Library).



Pony Ride pergola and riding ring, no date but likely 1950s. Note sycamore trees in background (replaced by carrotwood trees, date unknown) (Los Angeles Public Library).



Pony Ride riding ring with pergola in the background, no date but likely 1950s. Note sycamore trees within and surrounding ring (removed at unknown date) (Los Angeles Public Library).

Physical Description

Site and Setting

The Pony Ride Site is located at the southeast corner of Griffith Park, on the east side of Crystal Springs Drive and just north of Los Feliz Boulevard. A heavily vegetated strip of land provides a buffer between the facility and Interstate 5. The southern end of the site is also heavily vegetated with oaks, sycamores, and other shade trees. The Pony Ride comprises an irregularly shaped site, approximately 3-and-one-half acres in size. The main vehicular entrance is located at the north end of the site and leads to a paved surface parking lot (added in 1957) shared with the miniature train ride. A second vehicular entrance (added in 1957) is located to the south of the riding ring and provides maintenance/park vehicles access to the barn and corrals. A paved pedestrian entrance and walkway provides egress between the sidewalk and the entrance to the Pony Ride.

Most of the Pony Ride buildings and structures are concentrated at the north end of the site, to the west of the miniature railroad tracks.⁶⁷ The snack stand (constructed in 1960) is the northernmost building in the Pony Ride Site. The building is fronted by two areas of lawn planted with gold medallion trees and containing picnic tables. The lawns are bisected by a paved pedestrian path that accesses a parking lot to the north. The snack stand is surrounded by non-historic asphalt paving. South and southwest of the building are two circular brick planters (added at an unknown date) holding a jacaranda tree (south) and coast live oak tree (southwest).

To the southwest of the snack stand is the ticket booth (built between 1947-1952) and pergola (built 1947). The ticket booth is located directly north of the pergola, and the pergola overlooks the riding ring (built 1947) to the south. To the east of the pergola and riding ring is the pony sweep (built between 1989 and 2003). To the west of the riding ring is another fenced area and pavilion used for birthday parties (added between 2018 and 2019).

A vehicular drive for maintenance vehicles separates the riding ring from another fenced birthday pavilion (added 2016). At the end of the driveway is a gate that accesses the barn (built between 1964-1965) and corrals (built between 1964-1965).

⁶⁷ The train tracks are outside of the scope of this report.

Existing Conditions Photographs and Site Plans⁶⁸



Aerial view of Griffith Park (boundary outlined in dashed red line), with location of the Pony Ride Site noted (Google Maps, adapted by ARG, 2023).

⁶⁸ Refer to Appendix B for larger copies of the existing conditions Site Plan and Tree Identification Site Plan.

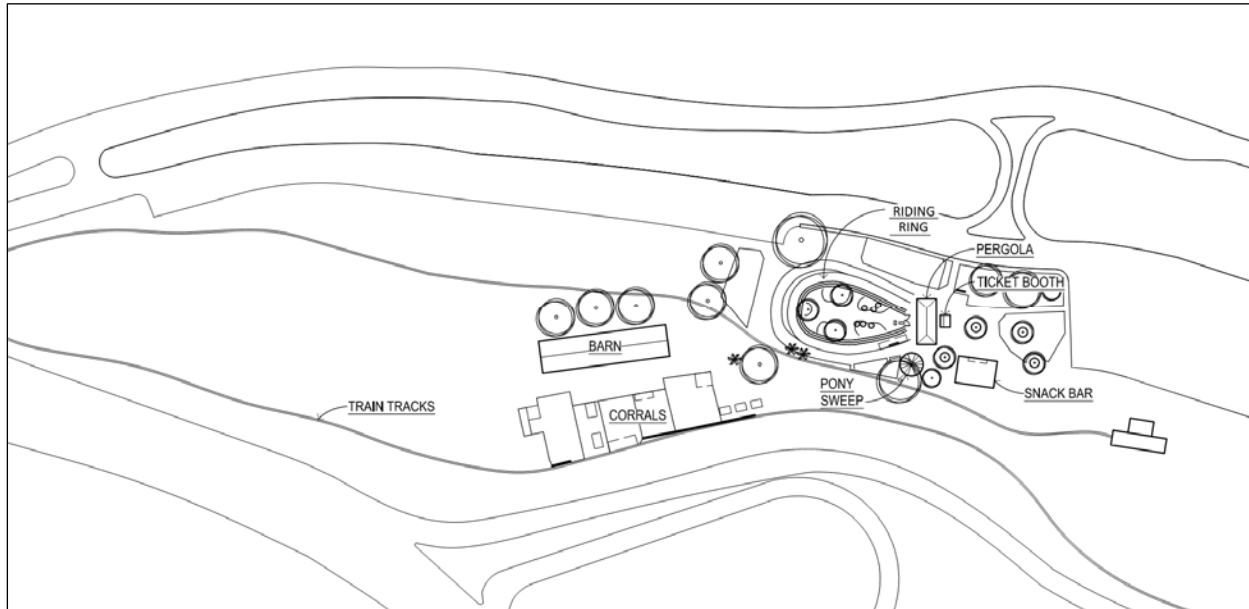

Griffith Park Pony Ride Context Site Plan (ARG, 2023).

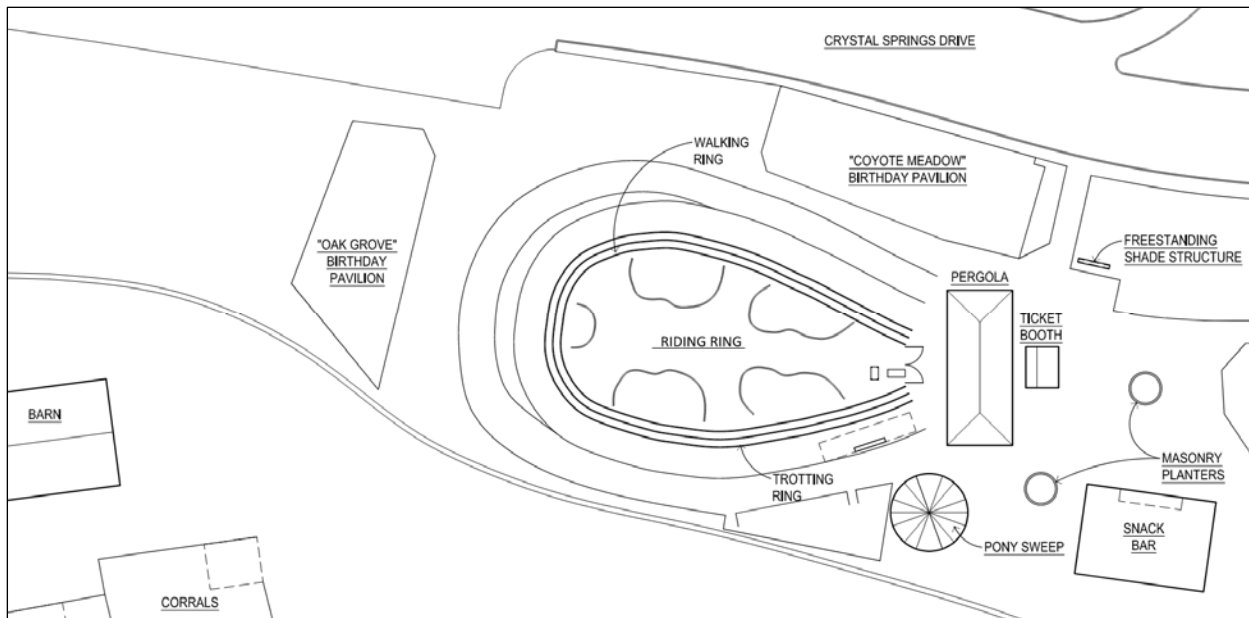

Griffith Park Pony Ride Site Plan (ARG, 2023).

Contributing Resources

Following is a description of the buildings, structures, and features that contribute to the significance of the Pony Ride Site. See the below Evaluation of Significance section for a complete list of the site's contributing and non-contributing resources.

Vegetation

The site contains numerous trees, including coast live oak, coast redwood, Mexican fan palm, carrotwood, jacaranda, gold medallion, and Canary Island pine trees (see Tree Identification Site Plan for location of tree species). The coast live oak and coast redwood trees are the only trees that appear to have been present on the Pony Ride Site during the period of significance (1947-1956) and thus contribute to its historic significance. Furthermore, one coast live oak, in a planter to the west of the snack stand, is identified as a Heritage Tree on the City's Navigate LA website.⁶⁹ See the below Evaluation of Significance section for a complete list of the site's contributing and non-contributing resources.

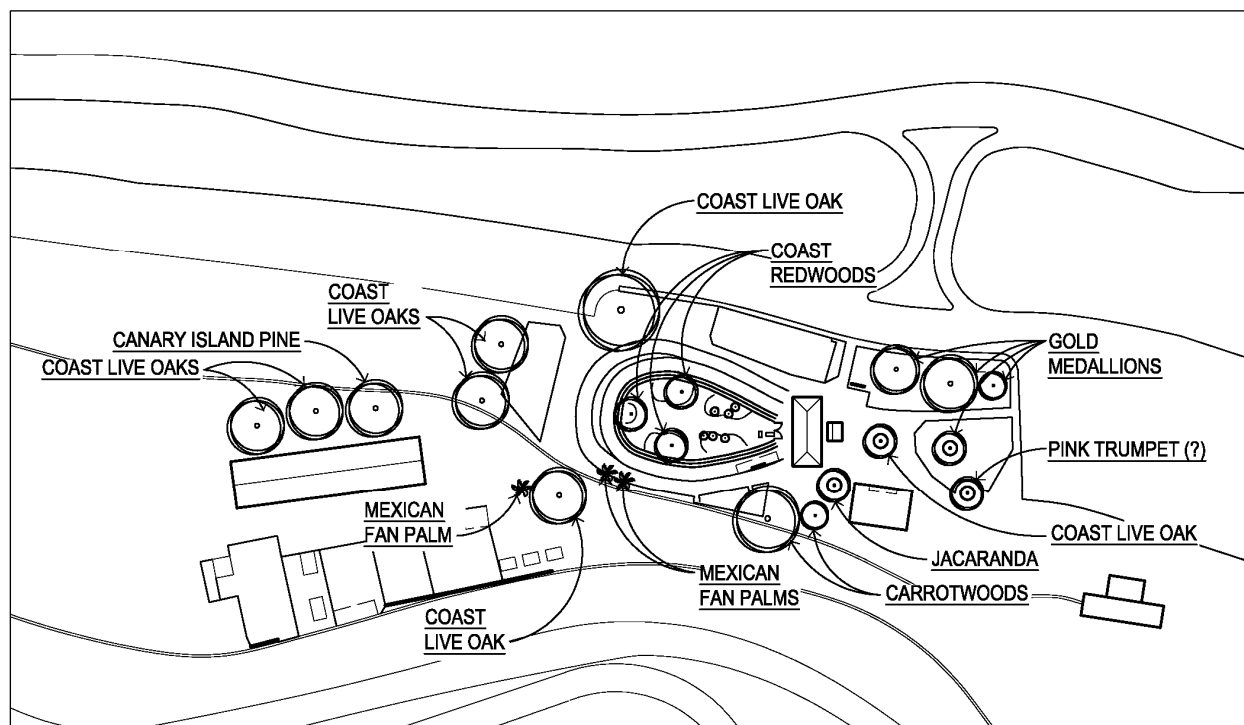

Griffith Park Pony Ride Tree Identification Site Plan (ARG, 2023).

⁶⁹ Refer to the City's Navigate LA website for more information about Heritage Trees: <https://navigatela.lacity.org/navigatela/>.



View of the three historic coast redwood trees in the riding ring (ARG, 2023).



View south of two historic coast live oak trees in the south birthday pavilion (ARG, 2023).



View west of the historic coast live oak at the vehicular staff/maintenance entrance (ARG, 2023).



View of historic coast live oak (left; identified by City of Los Angeles as a Heritage Tree) and jacaranda (right) in planters adjacent to the snack stand. Note non-historic paving surrounding the trees and snack stand (ARG, 2023).



View of non-historic Mexican fan palm trees to the southeast of the riding ring (ARG, 2023).



View north of the non-historic gold medallion trees near the pedestrian entrance (ARG, 2023).

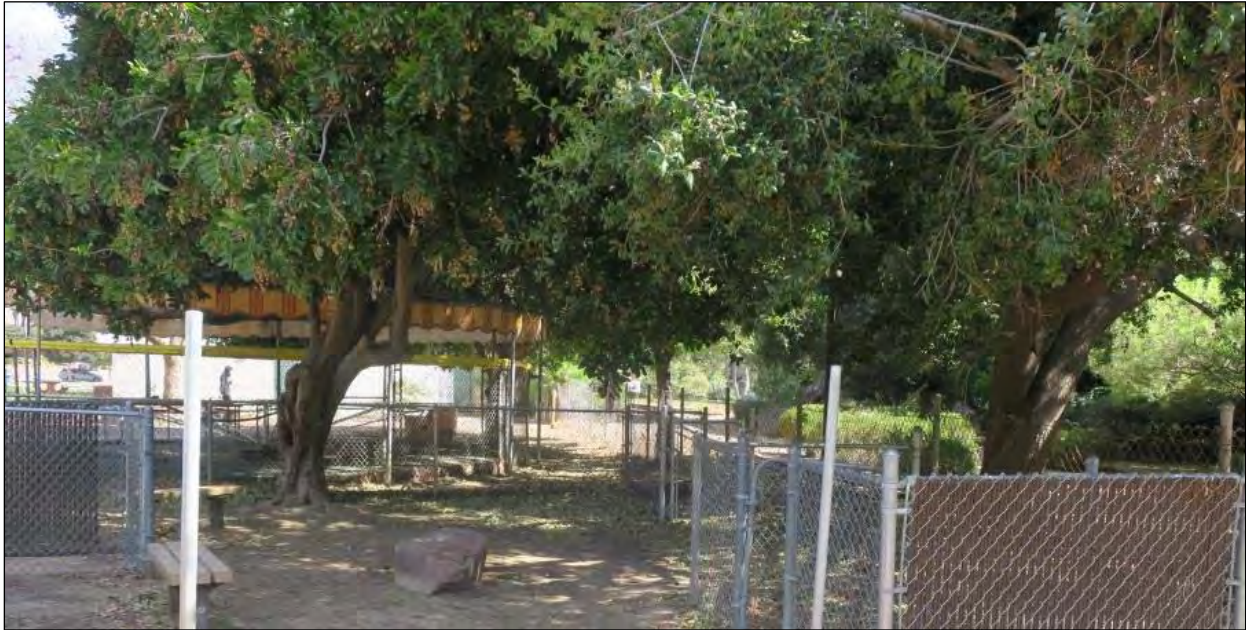

View of the non-historic carrotwood trees along the east end of the site, next to the pony sweep (ARG, 2023).

Pergola

Constructed in 1947, the pergola is original to the Pony Ride Site and contributes to its significance. The structure provided shelter for patrons who waited in line for a pony ride. It consists of an open, hipped roof structure with asphalt composition shingle roofing and exposed rafters and sheathing. The roof is supported by ten wood columns atop concrete footings (five on each side). Surface-mounted pipe conduits, outdoor paging/announcement speakers, and lights with jelly-jar style shades are located at the pergola ceiling. Below the roof are fixed pipe metal stanchions where patrons would queue up. Based on historic drawings and photographs, the stanchions are not original to the structure. Historically there were park benches placed along the north side of the pergola, and a wood picket fence enclosed the south side. The south side was also originally divided by diagonal wood railings into 12 pony stalls, with six to each side and a central pass-through between the pergola and pony area. The benches, picket fence and stall dividers are no longer extant, but the center pass-through remains. Along the south side of the structure are two long metal water troughs sitting on wood framing where ponies would be tethered and given water. A chain-link fence has been installed (date unknown) between the queue area and the water troughs. Metal tube framing with a synthetic covering has been mounted to the south edge of the pergola roof to provide additional shade to the ponies.

Existing Conditions Photographs, Pergola



View southeast of the pergola (ARG, 2023).



View north of the pergola from the riding ring. Note light pole in the foreground (ARG, 2023).



Close-up of south side of the pergola and water troughs (ARG, 2023).

Ticket Booth

Built between 1947 and 1952, the ticket booth was part of the original development of the Pony Ride Site and contributes to its significance. The ticket booth sits directly north of the pergola. It is a small one-story building capped with an asymmetrical gable roof with asphalt composition shingle roofing and exposed rafter tails. The south plane of the roof shelters an open porch where visitors buy their tickets. The south edge of the roof is supported by wood posts with a wood railing. The north roof plane covers an enclosed booth. The building is clad in vertical wood siding with a non-historic plywood wainscot (likely covered original horizontal cladding beneath). A service window enclosed by two wood shutters is centered on the south façade of the building. The ticket window consists of a wood-framed opening with exterior shutters and an interior acrylic infill panel. The acrylic infill panel has a vented opening for speaking through more easily, and an arched opening at bottom center to exchange money/tickets. A wood door centered on the north façade of the building leads to the interior of the booth.

The interior of the building consists of a concrete slab floor, painted gypsum board walls and ceiling, and simple wood base and ceiling trim. The ceiling is flat and cants down to follow the roof rafters along the north side. The south side contains built-in lower cabinets with a countertop and opening below the ticket window. The countertop continues along the west interior wall. Open shelving is located on the other walls.

Existing Conditions Photographs, Ticket Booth



View west of the ticket booth (ARG, 2023).



View southeast of the ticket booth (ARG, 2023).

Riding Ring

Originally developed in 1947, the riding ring is original to the Pony Ride Site and contributes to its significance. Located south of the pergola, the ring is horseshoe shaped with its narrower end terminating at the pergola. The inner ring consists of two narrow riding tracks—the inner track was historically used for walking and the outer for trotting. The tracks are divided by three guide rails, which are located approximately 14 inches off the ground and consist of square wood posts supporting horizontal wood rails. A two-foot-tall wood fence surrounds the walking and trotting tracks and forms a third track, which was historically the running track. The running track is surrounded by a 3-foot-tall fence with buggy wheels along the exterior of the fence; this historically formed the buggy track. The entire riding ring is surrounded by a metal chain-link fence (added at unknown date). Based on historic drawings and photographs, the running track fence and buggy fence replaced original fences that were 3'-10" high, with alternating stacked wood railings. The inner track guide rails appear to have been replaced in kind.

Near the north end of the center of the riding ring is a 20-foot-tall metal light pole supporting three spotlights. At the base of the pole is a u-shaped, wood-framed look-out booth where employees stand to oversee the tracks. The light pole appears to be original to the site based on historic photographs. The look-out booth was added at a later date (post-1991, per a historic newspaper image). Low concrete curbs delineate semi-circular planters that are planted with three coast redwood trees and manicured hedges (not original to the site based on historic photographs) within the center of the ring. At the northeast edge of the ring is a metal structure supporting an awning that shades additional water troughs (added at unknown date), and a concrete vault with a wood door (use unknown) is located in the ground next to the light pole.

Existing Conditions Photographs, Riding Ring



View northeast of the riding ring towards the pergola (ARG, 2023).



View south of the riding ring inner guide rails (ARG, 2023).

Non-Contributing Resources

Following is a description of the buildings, structures, and features that do not contribute to the significance of the Pony Ride Site. See the below Evaluation of Significance section for a complete list of the site's contributing and non-contributing resources.

Pony Sweep

Based on historic aerial photographs, the existing pony sweep appears to have been added between 1989 and 2003. As a contemporary intervention, it does not contribute to the historic significance of the Pony Ride Site. It is a circular structure of metal tube framing with a mesh fabric roof cover. The structure shelters a metal wheel/carousel (sweep) that ponies get tethered to while walking in a circular pattern. The structure comprises metal pipe framing and is enclosed on all sides by chain-link fencing. There is a single gate at the north side to enter/exit, and an array of metal pipe stanchions for crowd control (similar to stanchions at the pergola). The sweep framing forms a conical roof overhead with lighting, and the structure is covered with canvas mesh and a decorative valance awning at the top edge. The floor of the sweep is raised slightly and covered with a ring of rubber athletic flooring for the ponies, and gravel in the center.

Existing Conditions Photographs, Pony Sweep



View south of the pony sweep (ARG, 2023).

Snack Stand and Restroom Building

Constructed in 1960, the snack stand and restroom building was built after the Pony Ride Site's original development (1947-1956) and does not contribute to the site. The building sits at the north end of the site. It is a one-story building with a U-shaped footprint. It has a flat roof with built-up roofing and is constructed of painted concrete masonry units (CMU). The west side of the building is infilled with vertical wood siding and lined with four large openings where patrons order/pick up food; the openings are enclosed by metal roll-up doors. Hollow metal doors line the other façades. The east side of the building has an enclosed service yard, and the north end of the building contains a commercial kitchen and snack bar; the interior of the yard, kitchen, and snack bar were not accessible during ARG's site visit. At the south end of the building are public restrooms—the women's restroom is accessed from the west side and the men's from the east side. The restrooms have concrete floors, painted plaster walls, exposed steel decking and beams at the ceiling, laminate restroom partitions, and industrial-type stainless steel fixtures.

Existing Conditions Photographs, Snack Stand and Restroom Building



View northeast of the snack stand and restroom building (ARG, 2023).



View south of the snack stand with equipment yard to the left (ARG, 2023).

Barn

Built between 1964 and 1965, the barn was added after the original development of the Pony Ride Site (1947-1956) and does not contribute to its significance. The barn is located at the south end of the facility, on the east side of the miniature train tracks. It is a large rectangular structure with a low-pitched gable roof and corrugated metal siding resting on top of a CMU stem wall. The barn is accessed from the north and south ends via large rectangular openings enclosed by metal roll-up doors with inset pedestrian doors. The interior of the barn is largely open, with partial height CMU stalls along the east and west sides, an employee break area and a tack room with storage loft at the northeast and northwest corners, respectively, and an open turn-out area at the south end. Interior floors at the ground level are compacted soil. The roof's steel framing is exposed at the interior, as is the CMU and corrugated metal wall siding.

Existing Conditions Photographs, Barn



View south of the barn (ARG, 2023).



View northwest of the barn (ARG, 2023).

Corrals

Originally installed between 1964 and 1965, the corrals were added after the Pony Ride Site was originally developed (1947-1956) and does not contribute to its significance. The corrals are located east of the barn. They vary in size and shape, and are enclosed by metal chain-link fencing. Each corral has one or more shade structures comprising corrugated metal roofs supported by metal posts. Fencing and shade structures appear to have been replaced over the years.

Existing Conditions Photographs, Corrals



View northeast of the corrals (ARG, 2023).

Small-Scale Features

Birthday Pavilions

There are two fenced birthday pavilions on the site—the “Oak Grove” pavilion (built 2016) is located south of the riding ring, and the “Coyote Meadow” pavilion (built between 2018 and 2019) sits west of the ring. The pavilions feature shade structures, tables, and painted backdrops, presumably for photo opportunities. The pavilions are contemporary interventions and do not contribute to the historic significance of the Pony Ride Site.

Existing Conditions Photographs, Birthday Pavilions



View southeast of the south “Oak Grove” birthday pavilion (ARG, 2023).



View north of the west "Coyote Meadow" birthday pavilion (ARG, 2023).

Freestanding Shade Structure

Near the pedestrian entrance, northwest of the ticket booth and pergola, is a freestanding shade structure with a built-in water trough. The metal trough is clad in wood and supported by metal posts. A retractable awning supported by metal posts shades the water trough on either side. The structure was built after the Pony Ride Site's original development (1947-1956) and does not contribute to the significance of the site.

Existing Conditions Photographs, Freestanding Shade Structure



View of the freestanding shade structure (ARG, 2023).

Masonry Planters

There are two circular planters at the north end of the site—one north of the ticket booth, holding a coast live oak tree, and the other between the snack stand and pony sweep, holding a jacaranda tree. The planters are composed of rubble stone with a brick coping. The exact date of the planter construction is unknown; however, they were built after the Pony Ride Site’s period of significance (ending in 1956) and do not contribute to the significance of the site.

Existing Conditions Photographs, Masonry Planters



View of the masonry planter and historic coast live oak tree (ARG, 2023).



View of the masonry planter and jacaranda tree (ARG, 2023).

Evaluation of Significance

Overview of Significance

The Griffith Park Pony Ride Site contributes to the significance of Griffith Park, which was designated Los Angeles Historic-Cultural Monument (HCM) No. 942 in 2009. Griffith Park is designated under multiple HCM criteria. It is listed under Criterion 1 as one of the largest urban parks in the country, reflecting the large-scale philanthropy and City Beautiful Movement ideals of the late 19th and early 20th centuries. It is also significant for providing a reliable and secure water source to the City, which was critical to Los Angeles's early 20th century development and growth. Under Criterion 2, the park was determined to be significant for its association with a number of notable individuals, including the Griffith family (Colonel Griffith J., wife Tina Griffith, and son Van Griffith), Park Superintendent Frank Shearer, who oversaw the initial recreational and irrigation developments in the park, and Recreation and Parks Superintendent George Hjelte, who managed the expansion of various recreational activities during the post-World War II era. Under Criterion 3, the park was found significant for containing a number of "intact and expressive examples" of the Spanish Colonial Revival, Moderne, Greek Revival, and rustic "Park Style" designs. Under Criterion 4,⁷⁰ the park was found significant for containing several buildings and structures designed by notable architects, including John C. Austin & Frederic M. Ashley, in consultation with Russell W. Porter (Griffith Observatory), Peter K. Schabarum (Greek Theatre), William L. Pereira & Associates (former Children's Theater Costume Workshop, now "LA Shares"), and Jones, Emmons & Contini (Griffith Park Girls' Camp).⁷¹

The park was also found significant as a cultural landscape.⁷² According to the National Park Service (NPS), a cultural landscape is "a geographic area, including both cultural and natural resources and the wildlife or domestic animals therein, associated with a historic event, activity, or person or exhibiting other cultural or aesthetic values."⁷³ Griffith Park represents one of the largest municipal parks with urban wilderness in the United States, encompassing 4,210 acres of natural chaparral-covered terrain and landscaped parkland. In addition to its vast undeveloped wilderness, the park includes a wide variety of recreational amenities, from hiking and horseback riding trails and picnic areas to the Griffith Observatory and Greek Theatre. Founded in 1896 and largely developed by the early post-World War II period, the park comprises a vast array of both natural and cultural resources; it thus represents a significant cultural landscape.

Griffith Park's identified period of significance is 1896-1957, beginning with the year Colonel Griffith and his wife Tina Griffith gifted the City of Los Angeles the property for use as a public park, through its early postwar development under the direction of Superintendent Hjelte. The period of significance culminates with the construction of the Interstate 5 and State Route 134 freeways (completed in 1957) through the park and the

⁷⁰ HCM Criterion 4 was combined with HCM Criterion 3 in 2017.

⁷¹ ICF Jones & Stokes, "Griffith Park," 2-3.

⁷² Ibid, 3.

⁷³ Charls A. Birnbaum, ASLA, National Park Service, U.S. Department of the Interior, *Preservation Brief 36: Protecting Cultural Landscapes: Planning, Treatment and Management of Cultural Landscapes* (Washington, D.C.: National Park Service, 1994), accessed August 2023, <https://www.nps.gov/orgs/1739/upload/preservation-brief-36-cultural-landscapes.pdf>.

development of the landfill in Toyon Canyon (opened 1958), within the boundaries of the park. These events were the result of the city's rapid postwar growth and rendered the park vulnerable to overdevelopment in the mid-1960s and 1970s.

Constructed in 1947, the Griffith Park Pony Ride Site contributes to the significance of Griffith Park for its association with the new and expanded recreational amenities developed in the park in the immediate post-World War II period, under the direction of Superintendent Hjelte.⁷⁴ While the Griffith Park HCM application does not identify a period of significance for the Pony Ride Site, for the purposes of this HSR, ARG has identified a period of significance of 1947-1956. The period of significance begins with the year the facility opened and ends prior to the completion of Interstate 5 (1957), which resulted in a reduction of the Pony Ride grounds and reconfiguration of how the site was approached by the public. Subsequent changes were made to the Pony Ride Site in the late 1950s through the mid-1960s, including the construction of a parking lot to the north of the facility, the addition of a new vehicular/maintenance drive and removal of a grass training ring, and construction of the snack stand, barn, and new corrals.

Contributing and Non-Contributing Resources

The Griffith Park HCM application does not identify contributing and non-contributing resources within the Pony Ride Site. For the purposes of this HSR, ARG has assigned contributing and non-contributing statuses to the buildings, structures, and features within the facility. Contributing resources are those that were built or added during the Pony Ride Site's period of significance (1947-1956) and help to convey the reasons for which the site is significant. Non-contributing resources are those that were built or added outside the Pony Ride Site's period of significance.

⁷⁴ The scope of this HSR did not include a re-evaluation of the Pony Ride Site or its associated buildings, structures, and features for potential significance as individually eligible historic resources or as a cultural landscape. ARG's delineation of a period of significance for the Pony Ride Site and identification of contributing and non-contributing buildings, structures, and features relates to the Pony Ride Site's current status as a contributing area of the Griffith Park HCM.

Following is a list of contributing and non-contributing resources associated with the Pony Ride Site.

Resource Name	Year Built	Contributing Status	Notes
Pergola	1947	Contributing	
Ticket booth	1947-1952	Contributing	
Riding ring	1947	Contributing	
Historic vegetation (coast live oaks, coast redwoods)	1947 or earlier (oaks likely pre-dated the Pony Ride)	Contributing	One coast live oak, located in a planter to the west of the snack stand, is classified by the City as a Heritage Tree, per the Navigate LA website
Pony sweep	1989-2003	Non-Contributing	Outside period of significance
Snack stand/restroom building	1960	Non-Contributing	Outside period of significance
Barn	1964-1965	Non-Contributing	Outside period of significance
Corrals	1964-1965	Non-Contributing	Outside period of significance
Birthday pavilions	2016	Non-Contributing	Outside period of significance
Freestanding shade structure	Post-1956	Non-Contributing	Outside period of significance
Masonry planters	Post-1956	Non-Contributing	Outside period of significance
Non-historic vegetation (gold medallions, palms, carrotwoods, jacaranda)	Post-1956	Non-Contributing	Outside period of significance

Contributing and Non-Contributing Resource Maps

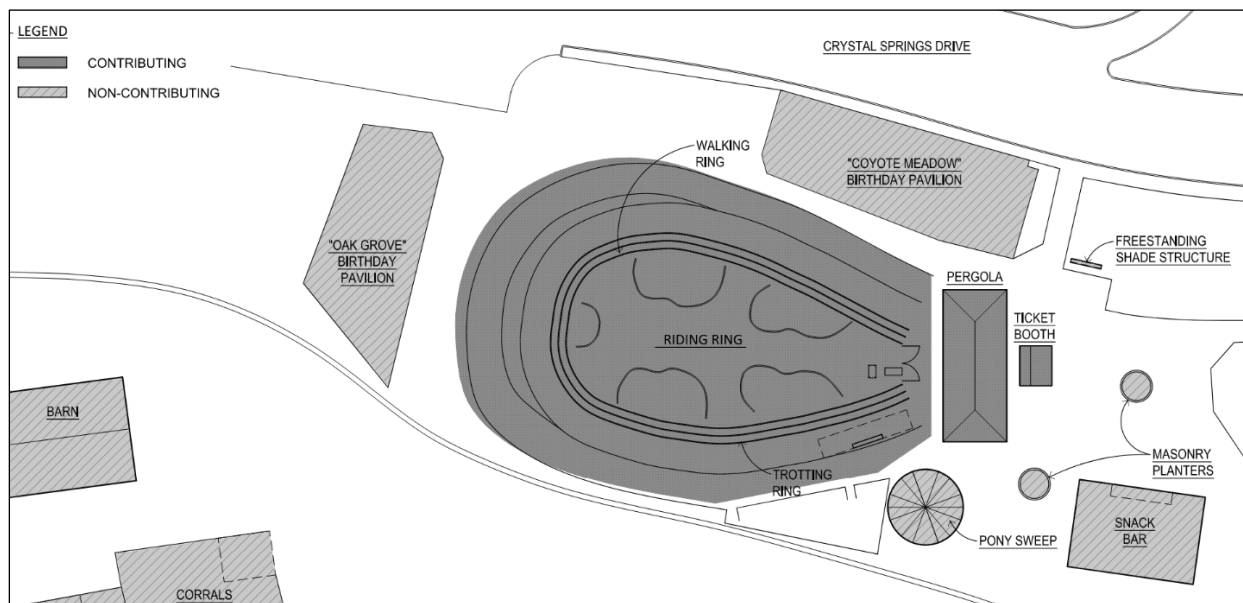

Pony Ride Site Contributing and Non-Contributing Buildings, Structures, and Small-Scale Features (ARG, 2023).

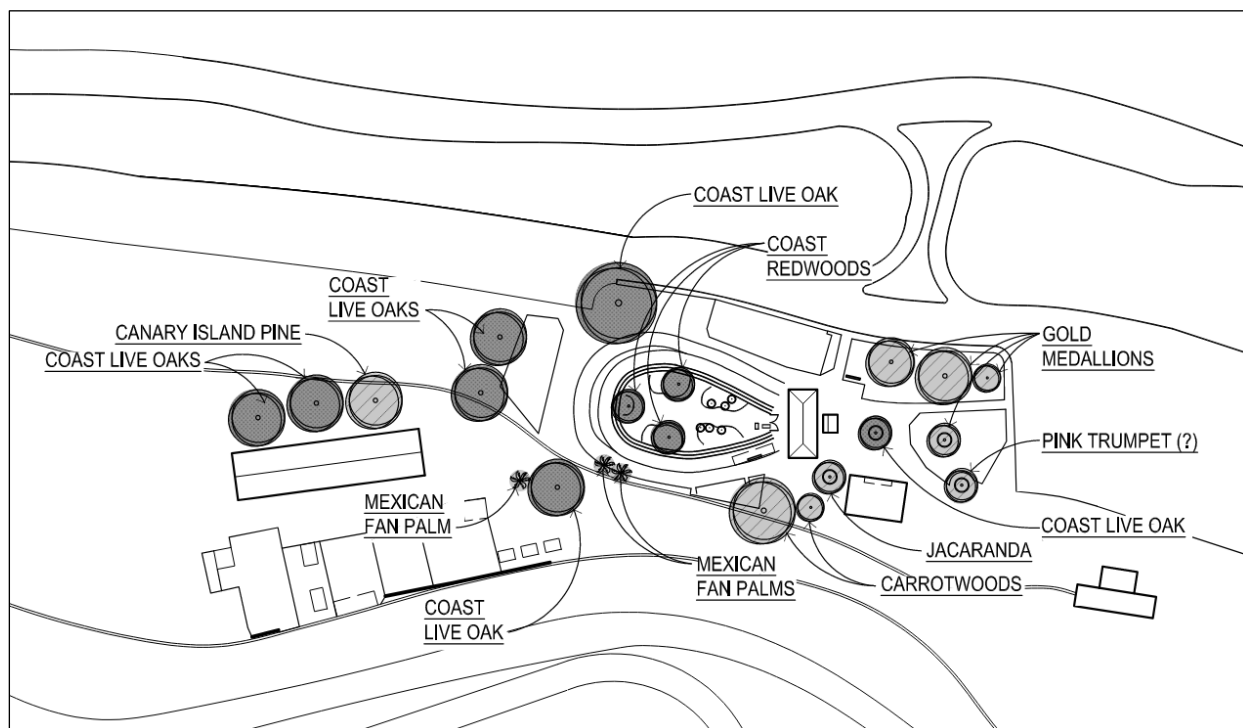

Pony Ride Site Contributing and Non-Contributing Vegetation (ARG, 2023).

Character-Defining Features

Character-defining features are those aspects of a property's design, construction, or detail that are representative of its significant function, type, or architectural style. Character-defining features may include the overall shape of the building/structure; its materials, craftsmanship, and decorative details and features; and the various aspects of the surrounding site. For a historic resource to retain its significance, its character-defining features and spaces must be retained to the greatest extent possible. An understanding of a property's character-defining features is a crucial step in developing a rehabilitation plan that incorporates appropriate levels of restoration, rehabilitation, maintenance, and protection.

Following are character-defining features of the Griffith Park Pony Ride Site and its contributing resources.

Site and Setting

- Siting on an irregularly shaped piece of land on the east side of Crystal Springs Drive
- Open developed areas surrounded by dense mature vegetation to the south and east
- Mature coast live oak trees scattered throughout the site and coast redwood trees in the riding ring (see Tree Identification Site Plan)
- Groupings of functionally related areas—public areas to the north (ticket booth, pergola, riding ring) and staff/maintenance areas to the south (barn, corrals)—separated by the miniature train tracks
- Low-scale, vernacular character and relatively small footprints of buildings and structures within the public area

Pergola

- Rectangular footprint
- Hip roof
- Open-air structure composed of exposed wood joists/beams and wood posts on concrete footings (some framing and footings have been replaced)

Ticket Booth

- Rectangular footprint
- Gable roof
- Wood construction and wood siding (some siding replaced/covered up)
- Recessed porch on the south side
- Door accessing the north side
- Service window with wood shutters on the south side

Riding Ring

- Horseshoe shape
- Wood guide rails comprising multiple tracks for walking, trotting, etc. (the rails themselves have been replaced)
- Landscaped center with historic redwood trees
- Light pole

Existing Conditions Assessment

Introduction

ARG has prepared the following architectural conditions assessment for the built features of the Griffith Park Pony Ride Site, in order to evaluate the existing materials and determine recommendations for preservation, mitigation, and/or repair strategies. This conditions assessment discusses each structure or feature separately. These include the contributing features (Pergola, Ticket Booth, and Riding Ring), and non-contributing features (Pony Sweep, Barn, Corrals, Snack Bar and Restroom Building, and other small-scale features).

The scope of this report is based on a visual analysis of accessible building materials and features, and includes only those areas immediately available for access. ARG did not survey concealed areas, perform exploratory openings, or remove materials for access. There may be conditions of interest and/or damage in concealed areas which are beyond the scope of this conditions assessment. An analysis of structural systems has been provided separately (see Appendix A: Structural Report).

Additionally, the scope of this report did not include an assessment of the health or condition of historic and non-historic vegetation within the Pony Ride Site. Refer to the Treatment and Recommendations section below for more detail regarding ARG's recommendations related to assessing the site's historic trees.

Contributing Resources

Pergola

The pergola, a contributing feature of the Pony Ride Site, was constructed in 1947. It consists of a single-story covered open space with wood columns and metal stanchions for crowd control, and troughs along the south side for ponies to be tethered and given water. The space is covered by a large, hipped roof with wide overhangs. The pergola roof is supported by 10 equally spaced wood columns, including 8x8 corner posts, and 6x6 interior posts. The columns are embedded in concrete footings and are also attached with steel base plates and bolts. It is unclear if the concrete footings are reinforced. Above the columns are continuous wood beams consisting of two 3x8's sistered together. The columns and beams are tied together with steel plates and bolts forming welded T-shapes. The columns are raised above grade by the footings and appear to remain in good condition. Some concrete footings have cracks, suggesting there may be some corrosion of embedded steel. Column/footing and column/beam connection plates where visible are painted and remain in good condition. At one location on the south side, the steel T-shaped connector is broken, and a surface-mounted strap connector has been added as a repair. The column also appears to have been cut and a wood block added between the column and beam.

The columns and beams support the pergola roof, which consists of 2x8 wood rafters spaced at 24 inches on center and 2x6 wood collar ties at 48 inches on center. The roof cantilevers out 6 feet in all directions to form a wide overhang. The roof is sheathed with 1x6 straight board sheathing and covered with asphalt

composition shingles. The roof eaves have a 2x8 continuous fascia trim, which is partially covered by painted sheet metal edge flashing. Roof drainage is by surface flow to the edges of the canopy; no gutters or downspouts are provided. At the east side of the roof, there are several small penetrations for a metal-framed cable stand, for feeding conduits to an electrical box below. At the pergola ceiling, there are surface-mounted pipe conduits, outdoor paging/announcement speakers, and ceiling-mounted lights with jelly-jar style shades.

The pergola roof is in fair condition overall. The wide overhangs are not braced typically, and in some corners there is minor roof sag. At the southwest corner, a diagonal pipe brace has been added for support. The roof framing and sheathing are typically soiled overall, with localized areas of peeling paint or paint loss. The straight sheathing boards have splits, losses, and open knotholes throughout. Some localized areas also may contain dry rot. The asphalt shingles and edge flashing remain in good condition. The cable stand metal surfaces are corroded, and the roofing tar penetrations appear deteriorated. Along the south side above the pony staging area, a large shade canopy has been added. The canopy is supported by galvanized pipe columns which cantilever out from the south wall and are affixed to the wood columns and beams. It is in fair condition overall, but could be damaging to the pergola framing in high winds.

The entire floor and surrounding area are paved with asphalt and hold stanchions. The metal stanchions are composed of painted metal 1-1/2-inch diameter pipe columns and rails, with half-round end caps; some openings are also closed off by chains. Additional direction and stop markings have been painted onto the asphalt below. The asphalt is in fair condition. It appears to drain sufficiently with no ponding water or low spots observed. There is cracking throughout. The pipe stanchions are also in fair condition. Metal surfaces have peeling paint and light corrosion throughout. Some end caps are also missing at rails.

Both the stanchions and markings are not original to the structure. Drawings and historic photographs indicate that there were park benches placed along the north side, and there was a painted wood picket fence along the south side with short return walls at the ends. The south side was also originally divided by diagonal wood railings into 12 pony stalls, with six to each side and a central pass-through between the pergola and pony area. The benches, picket fence and stall dividers are no longer extant, but the center pass-through remains. It features wood door panels with double-acting hinges and remains in good condition. Chain-link fencing has also been added at the south wall between the pergola and troughs and continues around the riding ring (see below).

The watering troughs are wood framed with stainless steel inserts, and in front there is a pipe rail for tethering the ponies. Water spigots with short rubber hoses are located above the troughs to either side of the columns. The flooring in this area is paved asphalt, and there are two area drains. The troughs remain in fair condition and appear well used. Surfaces are soiled and abraded with paint loss throughout. Trough inserts and floor drains are clogged with leaves and debris.



View looking southeast showing pergola and stanchions (ARG, 2023).



View looking northwest showing pergola and pony trough area (ARG, 2023).

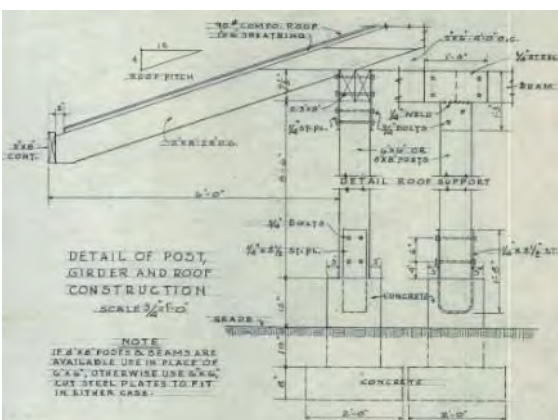

Section detail through pergola showing roof/column framing and foundation (Department of Parks, City of Los Angeles, Board of Park Commissioners, 1946).



Detail at typical column base; note cracks in concrete footing (ARG, 2023).



Detail at typical column/beam connection with T-shaped steel plates and bolts (ARG, 2023).



Detail at column; note metal strap repair at connection plate (ARG, 2023).



View of pergola ceiling; note light fixture and exposed conduit (ARG, 2023).



Detail of board sheathing; note splits, knotholes, and losses (ARG, 2023).



Detail at east side of roof showing cable support device (ARG, 2023).



Detail at southwest corner of roof; note additional brace at overhang (ARG, 2023).



Shade structure added at south side (ARG, 2023).



Stanchions and directional markings at asphalt pavement; note cracks and missing end cap (ARG, 2023).

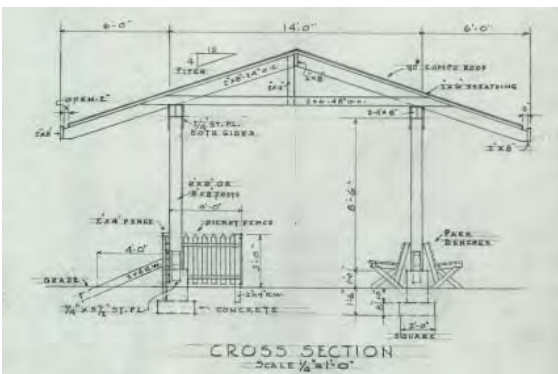

Cross section through pergola; note benches, picket fence, and stall divider (Department of Parks, City of Los Angeles, Board of Park Commissioners, 1946).

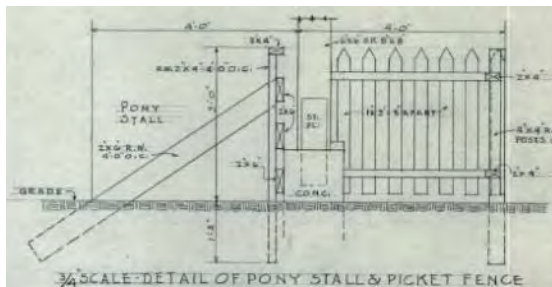

Detail of picket fence and stall divider (Department of Parks, City of Los Angeles, Board of Park Commissioners, 1946).



View of central pass-through with double-acting panels (ARG, 2023).



Detail at trough and tethering rail (ARG, 2023).



Detail at column with water spigots and hoses (ARG, 2023).



Detail at trough; note leaves/debris (ARG, 2023).

Ticket Booth

The Ticket Booth, a contributing feature of the Pony Ride Site, was constructed sometime between 1947 and 1952. It consists of a small, one-story, one-room building with an asymmetrical gabled roof. At the south side, there is a covered porch and ticket window, and at the north side there a single entrance door. The building is composed of wood-frame construction, supported on a concrete slab-on-grade foundation. Exterior walls consist of wood 1x8 vertical siding over a modified wainscot base. The wainscot currently consists of a wood 2x sill with plywood cladding below. The plywood is covering possibly original wood horizontal siding. The roof is framed with 2x4 wood rafters at 24 inches on center, supported by 2x6 wood beams. The roof is sheathed with straight board sheathing and covered with asphalt composition shingles, similar to the pergola roof. Drainage is by surface flow to the north and south sides of the building (no gutter). There is one small pipe penetration at the north side above the entrance for security lighting.

The roof is in fair condition overall. A few asphalt shingles appear damaged, and there is heavy sealant or roof tar around the pipe penetration, which is poorly applied. Edge flashings are intact with some dents throughout. The ends of several rafter tails are also heavily decayed (rotted). The vertical siding at the upper portion of walls is in fair condition and appears to be original. The siding is split and damaged in localized areas. At the west façade, a large rectangular opening was cut for installation of a packaged air conditioning unit. The unit has since been removed and the opening covered with plywood. There is also wood rot and peeling paint at the base of boards where they meet the wood sill. Painted surfaces are generally intact but soiled overall with some graffiti noted.

The lower portion of the walls is in poor condition. The wood sill appears to be original. It is damaged in several areas, with notches or losses, some of which have been painted over. Plywood has been installed at the wainscot over what may be original horizontal siding. Where visible near the entrance, the horizontal siding is in poor condition, including heavy wood rot at the base of the building. Some base boards may have also been removed. It is difficult to determine the full extent of damage without removing the plywood covering.

The covered porch at the south side is framed with 4x4 wood columns, and between the columns are 2x4 intermediate and top railings. The railings appear to be replacements. Wood brackets remain at the columns from an earlier installation and at a lower height. The porch is in fair condition overall. There is wood decay (rot) at the base of wood columns and ends of railings. Railing surfaces are generally worn and damaged from use, with heavy paint loss.

The entrance door at the north façade is wood framed, with simple solid paneling at the interior, and wood trim at the exterior simulating a barn door with vertical boards and horizontal and diagonal bracing. The door is hung with decorative strap hinges; it also contains a locking knob entry set, deadbolt lock, and sliding bolt with padlock and heavy chain. Damage around the locks suggests multiple break-in attempts. The door is in poor condition overall. The wood frame is heavily rotted at the base of both jambs. The base of the door is also heavily damaged from rot and moisture infiltration. This is less visible at the exterior since a piece of wood trim has been added at the base of the door to cover the damage; at the interior, the paneling is

warped and water damaged.

The ticket window at the south façade consists of a wood-framed opening with exterior shutters and an interior acrylic infill panel. The shutters are composed of vertical boards with horizontal and diagonal trim at both interior and exterior sides. The shutters are designed to lay flat against the exterior south wall (secured by chains) when the ticket window is open; small notches have been cut into the exterior frame at each side for this purpose. The acrylic infill panel has a vented opening for speaking through more easily, and an arched opening at bottom center to exchange money/tickets. The shutters are hung with decorative strap hinges and secured with a non-original hasp and padlock and heavy chain. The ticket window is in fair condition overall. The shutters have been damaged, including multiple pry marks and losses at the wood, likely from prior break-in attempts. The base of the shutter doors and frame sit against the wood sill and appear to have some dry rot. The base of shutters has also been previously repaired (seen at interior side). The hinges are intact, but two additional hinges have been added at the eastern shutter. The sill and interior trim at the window opening are heavily worn from use.

The interior of the building is of fairly simple construction, including a bare concrete slab floor, painted gypsum board walls and ceiling, and simple wood base and ceiling trim. The ceiling is flat and cants down to follow the roof rafters along the north side. The south side contains built-in lower cabinets with a countertop and opening below the ticket window. The countertop continues along the west interior wall. The west wall also contains an opening for an A/C unit (now removed). Other walls contain open shelving supported on metal brackets. There are some loose furnishings still in the space, including a desk and file cabinet. The space is lit with a single fluorescent light at the ceiling. In general, the interior is in poor condition. Surfaces are heavily soiled and worn from use. There are numerous areas of damage to the base of wallboards, particularly below the ticket window and adjacent to the door jambs. The A/C opening at the west wall has been covered from the exterior (see above); other interior wall panels have been added at the interior east wall (use unknown).



North façade of ticket booth (ARG, 2023).



View looking northwest; note covered porch and ticket window (ARG, 2023).



Detail at roof; note heavy tar/sealant around pipe penetration (ARG, 2023).



Detail at northeast corner of roof; note heavy wood rot at rafter tail and dented sheet metal edge flashing (ARG, 2023).



Detail at east façade over porch; note splits in vertical siding (ARG, 2023).



Detail at northeast corner; note wood decay and peeling paint at base of siding; also note loss at wood sill (ARG, 2023).



Detail at west façade; note infill panel covering hole for A/C unit (ARG, 2023).



Detail near entrance; note horizontal siding beneath plywood wainscot (ARG, 2023).



Porch railings; note heavy wear damage and paint loss (ARG, 2023).



Detail at porch top rail; note wood bracket from previous railing (ARG, 2023).



Detail at base of porch column; note wood decay/rot (ARG, 2023).



Detail at door frame; note heavy wood decay/loss at frame and wall (ARG, 2023).



View of door exterior; note added base trim (ARG, 2023).

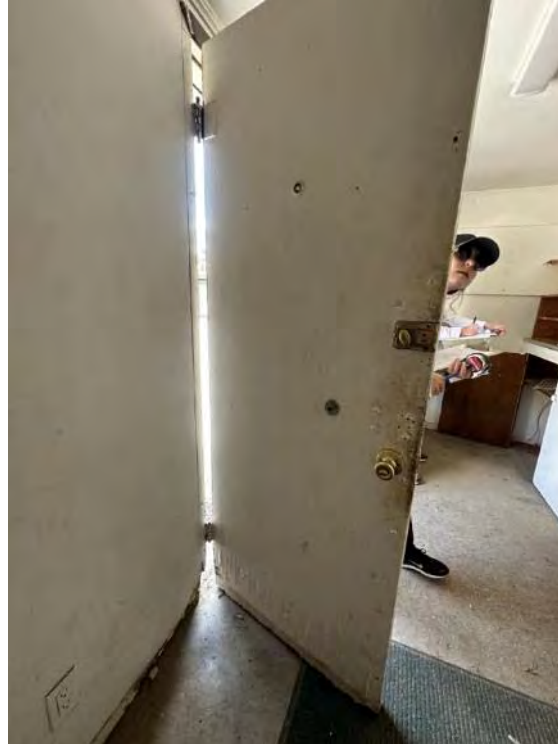

View of door interior; note overall wear (ARG, 2023).

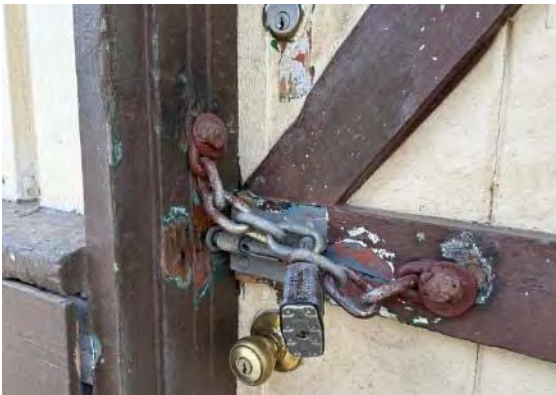

Detail of door hardware (ARG, 2023).



Detail at base of door interior; note door and wall damage (ARG, 2023).



View of ticket window exterior shutters (ARG, 2023).



View of ticket window interior acrylic panel (ARG, 2023).

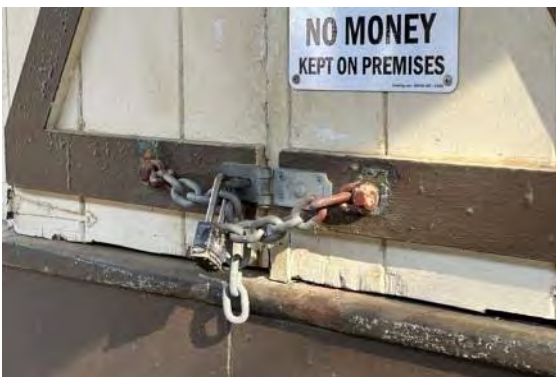

Detail of shutter hasp and padlock (ARG, 2023).



Detail of shutter hinges; note original strap hinge and notch in frame; also note hinge added later (ARG, 2023).



Interior view looking east (ARG, 2023).



Interior view looking west (ARG, 2023).



Detail at west wall A/C opening (ARG, 2023).



Detail of wall damage below ticket window (ARG, 2023).

Riding Ring

The riding ring, a contributing feature of the Pony Ride Site, is a horseshoe-shaped area located immediately to the south of the pergola. It was originally developed in 1947. It features four concentric riding tracks, including two narrow tracks at the inner rings for walking and trotting and two wider tracks at the outer rings, one for running and one for horse-drawn carriages (known as the buggy ride track). The rings are defined by wood-framed guide rails and fences.

The walking and trotting tracks have 14-inch-high guide rails consisting of 4x4 wood posts spaced approximately 8 feet on center and 2x4 top rails. The running track has a 2-foot-tall fence consisting of 4x4 wood posts spaced approximately 8 feet on center, and 2x4 wood rails at top and bottom. The buggy track has a 3-foot-tall fence consisting of 4x4 wood posts spaced approximately 8 feet on center, and 2x4 top, middle, and bottom rails. This fence also features wood buggy wheels embedded in the soil adjacent to the fence. The outer limits of the buggy track and riding ring area are defined by chain-link fencing; in some cases, a short portion of chain-link has been added above the buggy track fence. All of the wood posts appear to be embedded directly in the ground rather than set in concrete (further investigation needed to determine). Rails are typically connected to posts with two to three common nails. Based on original drawings and photographs, the existing guide rails and fences are replacements. The original design for the running and buggy ride track fences included 4x4 redwood posts, spaced 6 feet apart, with 2x4 top and bottom rails. The fences were 3'-10" high, and the railings alternated in a stacked fashion (see detail below). The inner guide rails appear to be similar to the historic photographs, just replaced in kind.

The riding ring tracks, guide rails, and fences are in fair condition overall. The ground is relatively flat throughout, but deeper ruts have developed within the tracks, particularly at the buggy ride track. One area at the south end is very deep (see photo below). Wood guide rails and fences are intact, but with localized areas of damage or wear, including peeling paint and paint loss; splits and losses to wood railings at nailed post connections; and heavily warped or sagging boards. Wood posts are set in the ground and prone to wood decay (rot) from moisture and termite damage.

The area in the center of the riding tracks is landscaped with mature trees and hedges and delineated by curving precast concrete curbs. The curbs are generally intact, but are covered with soil and debris. A few units have also shifted in the ground. At the north end of the riding ring is a 20-foot-tall metal light pole with overhead lighting. The pole is set in concrete and appears to be in good condition. Constructed around the light pole is a small wood-framed employee stand, which was added sometime after 1991. The stand has wood corner posts set in cement and is clad on three sides with wood vertical siding. The interior contains two shelves and a rack possibly used for holding drinks. It is in fair condition overall. Wood corner posts are damaged from termites and chew marks. The base of the siding is covered with soil and prone to wood decay/rot. Painted surfaces are soiled and weathered. At the north end of the riding ring, there is a pair of metal gates and an in-ground concrete vault (use unknown). The gates are in fair condition. Metal surfaces have light corrosion throughout. The vault is enclosed with a wood-framed cover which is deteriorated and partially collapsed.

At the northeast corner of the riding ring, there is an additional shade structure with a watering trough (date of construction unknown). It consists of galvanized metal pipe columns and cantilevered shade structure with canvas awning. The troughs are wood framed and lined with stainless steel inserts, and the troughs are supported on pipe columns. The structure is in fair condition. The pipe framing has localized areas of corrosion. The canvas awning is deteriorated and torn in many places and held to the framing with zip ties strung together.



View of riding rings looking north to pergola (ARG, 2023).



View of riding rings looking south; note ruts in track soil (ARG, 2023).

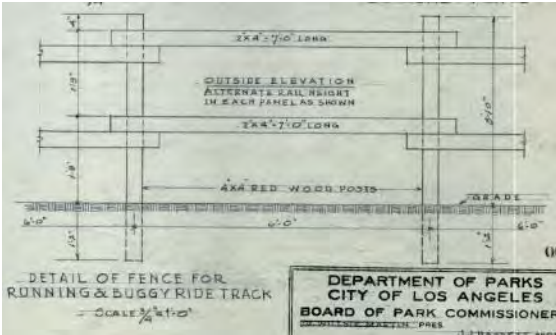

Detail of running and buggy ride track fencing (Department of Parks, City of Los Angeles, Board of Park Commissioners, 1946).



Historic view of running and buggy ride track fencing (Los Angeles Public Library, no date but likely 1950s).



Deep rut at south end of riding ring (ARG, 2023).



View of inner guide rails; note sagging rail (ARG, 2023).



Typical peeling paint at buggy track fence (ARG, 2023).



Typical splits and wood loss at guide rails/post connection (ARG, 2023).



View of light post, landscaped areas, and precast concrete curbs (ARG, 2023).



Detail of shifted curbs (ARG, 2023).



View of employee stand looking southwest; note soil collected at base (ARG, 2023).



View of employee stand looking northeast; note light pole at center (ARG, 2023).



Detail of employee stand; note chewed wood post and weathered paint finishes (ARG, 2023).



Detail of cup holders at stand; note termite damage at wood post (ARG, 2023).



Metal gates at north end of riding ring (ARG, 2023).



Concrete vault at north end of riding ring (ARG, 2023).



Shade structure and troughs at northeast corner of riding ring (ARG, 2023).



Detail at canvas awning; note tears and zip ties (ARG, 2023).

Non-Contributing Resources

Pony Sweep

To the east of the pergola and riding ring, there is a circular structure known as a “pony sweep”. Based on aerial photographs, it appears to have been added to the site sometime between 1989 and 2003 and does not contribute to the significance of the Pony Ride Site. The structure shelters a metal carousel (or sweep) from which tethered ponies walk in a circular pattern. The structure is composed of galvanized metal pipe framing and is enclosed on all sides by chain-link fencing. There is a single gate at the north side to enter/exit, and an array of metal pipe stanchions for crowd control (similar to stanchions at the pergola). The sweep framing forms a conical roof overhead with lighting, and the structure is covered with canvas mesh and a decorative valance awning at the top edge. The floor of the sweep is raised slightly and covered with a ring of rubber athletic flooring for the ponies, and gravel in the center. At the center is also a metal carousel with arm extensions that can tether up to nine ponies.

The pony sweep is currently in fair condition overall. The metal pipe-framed structure and fencing are intact,

but with localized areas of corrosion. The mesh covering at the roof is soiled and covered with heavy amounts of leaves and debris. The valance awning is heavily faded from UV-light and torn and frayed in some locations. The rubber flooring ring is soiled and deteriorated and has dips and ruts where water can collect. The carousel is operable and intact, but with some localized areas of corrosion. The metal stanchions are set in cement. Pipe surfaces are worn with paint loss throughout, and some decorative end caps are missing. Also, near the pony sweep entrance, there is an underground concrete drainage structure with a unique trapezoidal shaped opening and debris filter. The concrete slab surrounding the opening is heavily cracked, and there is soiling and debris throughout.



View of north side of pony sweep; note gate entry and stanchions (ARG, 2023).



View of metal stanchions (ARG, 2023).



Detail at top of conical roof pipe framing and lights (ARG, 2023).

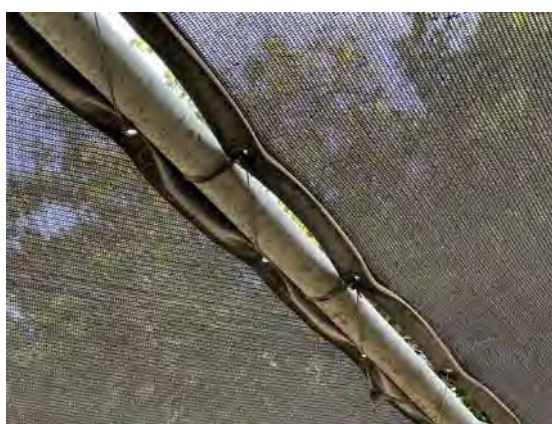

Detail of pipe framing and connection of mesh awning using zip ties (ARG, 2023).



Detail at roof awning; note heavy collections of leaves/debris, and stained and sagging mesh panels (ARG, 2023).



Detail at valance; note faded colors (ARG, 2023).



Detail at pipe framing and chain-link fence; note corrosion (ARG, 2023).



Detail at base; note pipe framing set in cement and raised interior floor (ARG, 2023).



Detail at rubber floor ring; note soiling and low spots (ARG, 2023).



View of carousel at center (ARG, 2023).



Detail at metal stanchions; note paint loss and missing end cap (ARG, 2023).



Concrete drainage structure near pony sweep; note cracking and debris (ARG, 2023).

Snack Stand and Restroom Building

The snack stand and restroom building was constructed in 1960 at the north end of the site and does not contribute to the significance of the Pony Ride Site. It is a one-story building with a U-shaped footprint, including a commercial kitchen at the north end, and public restrooms at the south end. The building is constructed of concrete masonry units (CMU), with a corrugated metal roof deck and built-up asphalt roofing. The roof is generally flat and contains rooftop HVAC units, kitchen exhaust hoods and other penetrations. ARG did not access the roof or kitchen at the time of the survey. The west façade is infilled with vertical wood siding and large openings with roll-up shutters for order and food pickup. Other doors around the building are typically hollow metal doors and frames, some with louvered vents. The east side of the building has an enclosed storage yard and a large opening with a pair of glazed doors and an infill panel. The restrooms are serviceable, and include concrete floors, painted plaster walls, exposed steel decking and beams at the ceiling, laminate restroom partitions, and industrial-type stainless steel fixtures.

The building appears to be in fair, serviceable condition. Based on available access, ARG noted typical damage from age and use, including localized areas of paint loss and corrosion, gouges and graffiti at CMU walls, scratches and graffiti at doors and restrooms, and soiling and stains. At the north façade, there is a large hole in the CMU block. The openings in the rear yard are heavily soiled and weathered. Glazed lights on the doors have been infilled with plywood. A temporary sign reading “Griffith Café” has been placed over the illuminated “Snack Bar” sign; the temporary sign is hanging loose.



View of snack stand looking northeast (ARG, 2023).



View looking northwest (ARG, 2023).



View looking southeast (ARG, 2023).



View of rear yard through fence, looking south (ARG, 2023).



View of HVAC and kitchen equipment at roof (ARG, 2023).



Loose temporary sign over existing illuminated sign (ARG, 2023).



View of snack bar order/pick-up windows with roll-up shutters (ARG, 2023).



Detail of paint loss and corrosion at metal frame (ARG, 2023).

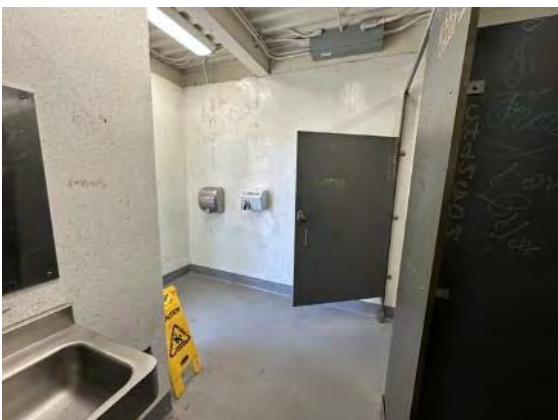

Interior view of women's restroom looking north (ARG, 2023).



Interior view of women's restroom looking south (ARG, 2023).



Detail of scratches at restroom door (ARG, 2023).

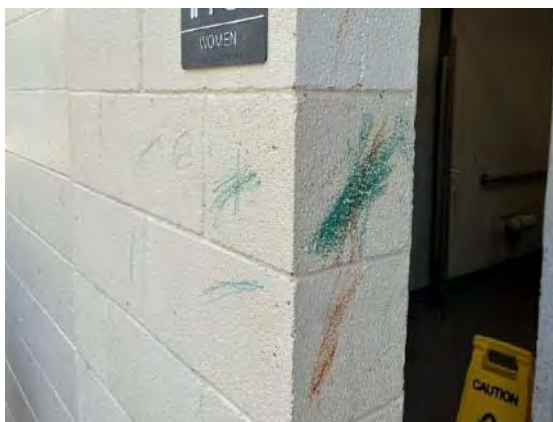

Detail of graffiti at CMU wall (ARG, 2023).

Barn

The barn was constructed between 1964-65 and does not contribute to the significance of the Pony Ride Site. It is located at the south end of the facility, on the east side of the miniature train tracks. The barn is a large steel-framed building, with a corrugated metal gable roof, and a combination of CMU walls at the base of the building and corrugated metal siding above. Roof drainage is by surface flow to sheet metal gutters and downspouts along the east and west sides. The CMU walls have vented units (breeze blocks) spaced throughout, and the metal siding has openings where clear and green corrugated polycarbonate panels are used as infill to allow for natural light. At the north and south ends, there are pedestrian access doors, inserted within large overhead doors that can be opened for additional light and ventilation. The interior contains partial height CMU partitions which form stalls along the east and west sides. At the northeast corner, there is an employee break area containing lockers and a picnic table. At the northwest corner, there is an enclosed tack room with a wood stair to a small storage loft above. The south end of the barn remains open as a small riding space or turn-out area, with chain-link gates dividing it from the stalls. Interior floors at the ground level are compacted soil. The steel framing, CMU, and corrugated siding and roofing are exposed at the interior. Some finishes are provided in the tack room area, including painted plaster walls, concrete floor at the tack room, and plywood floor at the loft above. The tack room has wood-framed saddle racks along the walls.

The barn remains in fair, serviceable condition. The steel framing appears sound and in good structural condition. Exterior walls and cladding remain intact; although some localized damage was noted including bent and gouged corrugated siding sheets, gouges in CMU walls, and areas of corrosion. A large area of corrosion was noted at the edges of corrugated roofing sheets along the west wall of the loft. Similar corrosion can be expected in other areas along the east and west sides. The roof panels could not be seen from the exterior (no access), so their condition is unknown at this time; however, daylight and pinholes were noted at the interior, particularly near the eaves. The polycarbonate panels remain intact, but their surfaces are heavily soiled. Overhead doors and man doors are operable and in serviceable condition; corrosion was noted throughout, and particularly at the base of doors. The compacted earth flooring has large depressions and stains throughout, and typically at locations where ponies may have been tethered. Urea stains and efflorescence (salt deposits) were noted at the floor and CMU walls. The tack room and loft are heavily soiled with stains and debris. Rodent droppings and insects were also noted at the loft.



View of barn looking southwest (ARG, 2023).



View of barn looking northwest (ARG, 2023).



Interior view of barn looking south (ARG, 2023).

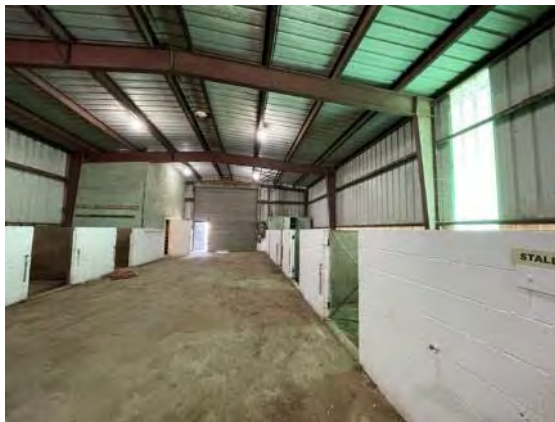

Interior view of barn looking north (ARG, 2023).



Detail at upper northeast corner/roof (ARG, 2023).

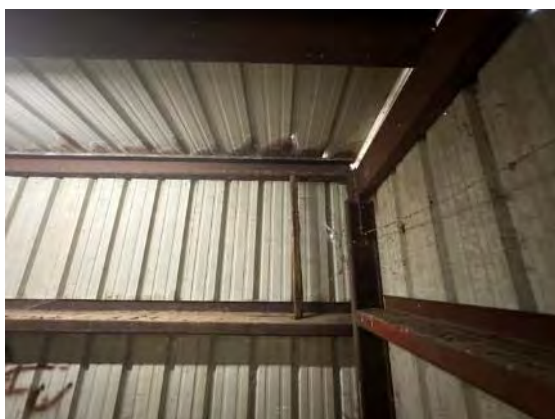

Interior detail at upper northwest corner; note corrosion at roof edge (ARG, 2023).



Detail at east exterior wall; note corrugated polycarbonate "window" panel (ARG, 2023).



Detail at overhead door with pedestrian door inset (ARG, 2023).



Typical damage at base of metal cladding (ARG, 2023).



Gouges at base of CMU wall (ARG, 2023).



View of stalls at east side (ARG, 2023).



View of stalls at west side (ARG, 2023).



Detail at open area at south end; note staining and efflorescence (ARG, 2023).



View of employee break area at northeast corner (ARG, 2023).

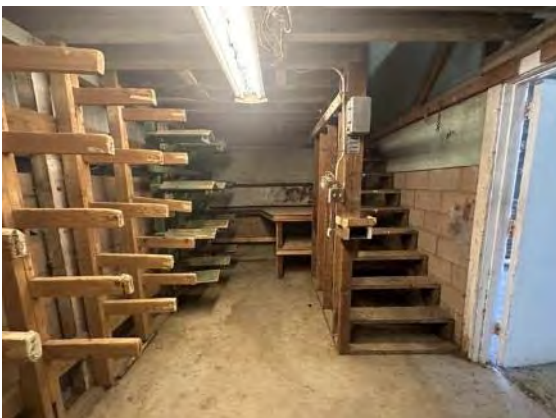

View of tack room and stairs to loft (ARG, 2023).



View of loft looking south (ARG, 2023).

Corrals

The corrals, which do not contribute to the significance of the Pony Ride Site, are located to the east and south of the barn. Developed between 1964-65, the area is generally open with some shade trees along the perimeter. It has been divided into several spaces with chain-link fencing and gates. Each corral space has one or more shade structures, consisting of galvanized metal pipe framing and corrugated sheet metal roofs. The fencing and shade structures are in fair condition and show signs of heavy use.



Overall view of corrals (ARG, 2023).



Shade structure and fencing at corrals (ARG, 2023).

Small-Scale Features

There are various other small-scale features found throughout the site. Existing conditions are as follows:

Birthday Pavilions

The site contains two large, fenced areas for birthdays and other events. These pavilions do not contribute to the significance of the Pony Ride Site. The first, titled “Oak Grove”, was constructed south of the riding ring in 2016. It features a train theme, with painted train car signage panels. The second event space, titled “Coyote Meadow”, was constructed in 2018 -19 to the west of the riding ring, and features a large signage wall painted to simulate a western town. Each space is enclosed with wood fencing decorated with wagon wheels, and there is a temporary pavilion structure with picnic table seating. Both spaces remain in good condition.



“Oak Grove” birthday pavilion (ARG, 2023).



“Coyote Meadow” birthday pavilion (ARG, 2023).

Freestanding Shade Structure

Near the entrance to the site, northwest of the ticket booth, is a freestanding shade structure complete with built-in water trough (build date unknown). The structure does not contribute to the significance of the Pony Ride Site. It is supported by galvanized metal pipe framing, and features a wood trough with stainless steel insert, a pipe rail for tethering ponies, and a retractable shade awning to each side. The structure is in fair condition overall. ARG did not detract the awnings to see if they remain operable. The wood trough has paint loss. Other finishes are soiled, and there is debris in the trough.



View of freestanding shade structure (ARG, 2023).



Detail of trough and tethering rail (ARG, 2023).



Detail of retractable awnings (ARG, 2023).

Masonry Planters

There are two larger circular-shaped planters around a jacaranda and historic coast live oak tree at the site, one located to the north of the ticket booth (holding the coast live oak), and one between the snack stand and the pony sweep (holding the jacaranda). The planters do not contribute to the significance of the Pony Ride Site. They are both constructed with stone rubble masonry walls and have brick paver copings. The planters are full to the coping height at the interior with compacted soil and tree roots. The planter near the ticket booth is in good condition, with just eroded stone mortar joints and some graffiti observed. The planter

near the pony sweep is in fair condition and appears to be under stress from the tree roots and/or outward pressure of the soil. The planter walls are cracked and separated in two locations, with large gaps in the stone masonry and two missing brick paver units.



Circular planter to north of ticket booth (ARG, 2023).



View of planter wall; note gaps in stone masonry and eroded joints (ARG, 2023).



View of planter wall; note graffiti at brick paver (ARG, 2023).



Circular planter between snack stand and pony sweep (ARG, 2023).



View of planter wall; note cracking and missing paver (ARG, 2023).



Detail at planter wall; note large separation and missing paver (ARG, 2023).

Part II: Treatment and Work Recommendations

Historic Preservation Objectives

Selection of a Treatment Approach

The Griffith Park Pony Ride Site is a contributor to Griffith Park, which was listed as a Los Angeles Historic-Cultural Monument (HCM) in 2009. Constructed in 1947, the Griffith Park Pony Ride Site contributes to the significance of Griffith Park for its association with the new and expanded recreational amenities developed in the park in the immediate post-World War II period, under the direction of Superintendent Hjelte.

Because the Pony Ride Site contributes to the historic significance of Griffith Park, a designated HCM, the City of Los Angeles requires that any future repair, maintenance, or rehabilitation of the site shall be guided by *The Secretary of the Interior's Standards for the Treatment of Historic Properties* ("the Standards"). The Standards provide general guidance for stewards of historic properties to determine appropriate treatments. They are intentionally broad in scope so that they can be applied to a wide range of circumstances and are designed to enhance the understanding of basic preservation principles. The Standards identify four defined levels of treatment for a property. Each level of treatment is accompanied by its own set of standards that serve to guide the approach to work.

Generally, in planning for anticipated work on a historic property, one of the four treatment levels is selected as the overall approach to treatment.

The four treatment approaches are as follows:

Preservation is the act or process of applying measures necessary to sustain the existing form, integrity, and materials of a historic property.

Rehabilitation is the act or process of making possible a compatible use for a property through repair, alterations, and additions while preserving those portions or features which convey its historical, cultural, or architectural values.

Restoration is the act or process of accurately depicting the form, features, and character of a property as it appeared at a particular period of time by means of the removal of features from other periods in its history and reconstruction of missing features from the restoration period.

Reconstruction is the act or process of depicting, by means of new construction, the form, features, and detailing of a non-surviving site, landscape, building, structure, or object for the purposes of replicating its appearance at a specific period of time and in its historic location.

Based on ARG's understanding of the Pony Ride Site's significance, its existing conditions, and its potential for future use, ARG recommends the **Rehabilitation** approach to treatment. The Standards for Rehabilitation recognize that change is often necessary for the adaptive reuse or continued use of a property and thus allow

for compatible, contemporary interventions through alterations, additions, and change in use, so long as the historic character⁷⁵ of the property is preserved.

To comply with the Standards for Rehabilitation, all interventions to the Pony Ride Site should be designed and constructed with a minimal loss of historic material. Additionally, they should be designed with an eye toward restoring altered or missing features from the site's 1947-1956 period of significance.

The Standards for Rehabilitation apply to all buildings, structures, and features within the Pony Ride Site, including non-contributing features, to the extent necessary to ensure their removal/replacement or alteration does not impact the historic character of the site.

Secretary of the Interior's Standards for Rehabilitation

Following are the Standards for Rehabilitation. These standards guide all treatment recommendations made herein and should inform all future work on the Pony Ride.

1. A property will be used as it was historically or be given a new use that requires minimal change to its distinctive materials, features, spaces, and spatial relationships.
2. The historic character of a property will be retained and preserved. The removal of distinctive materials or alteration of features, spaces, and spatial relationships that characterize a property will be avoided.
3. Each property will be recognized as a physical record of its time, place, and use. Changes that create a false sense of historical development, such as adding conjectural features or elements from other historic properties, will not be undertaken.
4. Changes to a property that have acquired historic significance in their own right will be retained and preserved.
5. Distinctive materials, features, finishes, and construction techniques or examples of craftsmanship that characterize a property will be preserved.
6. Deteriorated historic features will be repaired rather than replaced. Where the severity of deterioration requires replacement of a distinctive feature, the new feature will match the old in design, color, texture, and, where possible, materials. Replacement of missing features will be substantiated by documentary and physical evidence.
7. Chemical or physical treatments, if appropriate, will be undertaken using the gentlest means possible. Treatments that cause damage to historic materials will not be used.
8. Archeological resources will be protected and preserved in place. If such resources must be disturbed, mitigation measures will be undertaken.

⁷⁵ Historic character refers to all those visual aspects and physical features that comprise the appearance of a historic property.

9. New additions, exterior alterations, or related new construction will not destroy historic materials, features, and spatial relationships that characterize the property. The new work shall be differentiated from the old and will be compatible with the historic materials, features, size, scale and proportion, and massing to protect the integrity of the property and its environment.
10. New additions and adjacent or related new construction will be undertaken in such a manner that, if removed in the future, the essential form and integrity of the historic property and its environment would be unimpaired.

Treatment Recommendations

Introduction

ARG understands that there are no specific plans for reuse of the Griffith Park Pony Ride Site at this time, and that the Department of Recreation and Parks (RAP) seeks to understand historical conditions when considering feasibility for reuse of the property that should be called out in any future Requests for Proposals.

ARG has provided the following treatment recommendations related to the site's rehabilitation, repair, and maintenance. The items detailed below are primarily to address material distress or damage in order to prolong the life of the materials and to prevent further damage or more costly interventions in the future. Other recommendations are associated with returning some historic character-defining features to the property or renovating spaces or features for contemporary use. All of the below recommendations are in keeping with the Standards for Rehabilitation. Any future plans involving reuse of the Pony Ride should undergo further review by a qualified historic architect meeting the *Secretary of Interior's Professional Qualifications Standards*, to ensure consistency with the Standards for Rehabilitation.⁷⁶

Similar to the Existing Conditions Assessment section, Treatment Recommendations have been grouped into general recommendations as well as by structure or feature. These include the contributing features (Pergola, Ticket Booth, and Riding Ring), and non-contributing features (Pony Sweep, Barn, Corrals, Snack Bar and Restroom Building, and other small-scale features). Recommendations regarding the treatment of vegetation are included under the general rehabilitation and maintenance recommendations. Structural recommendations have also been summarized in this section; see Appendix A for the complete structural report. In general, recommendations are listed in order of priority (high to low).

⁷⁶ National Park Service, Code of Federal Regulations, 36 CFR Part 61, <https://www.nps.gov/articles/sec-standards-prof-quals.htm>.

General Recommendations

- New construction within the Pony Ride Site should be reviewed by a qualified historic architect to ensure consistency with the Standards.
- Consider a comprehensive code analysis to review for conformance with applicable codes related to egress, fire protection, occupant loads, etc. when a new use for the Pony Ride facility is determined.
- Consider conducting an Americans with Disabilities Act (ADA) accessibility study when a new use for the Pony Ride facility is determined.
- The following maintenance items should occur annually:
 - Clean and maintain existing roofs and drainage systems. Remove leaves and debris from roof surfaces, gutters, and downspouts. Inspect roofs at minimum annually, and following large rainstorms, high winds, or seismic events.
 - Clean and remove debris from floor drains, area drains, in-ground structures or vaults, and troughs.
 - Clean exterior building surfaces and remove graffiti if necessary; sweep out interior spaces and monitor for leaks or other damage.
 - Maintain protective paint coatings at character-defining features and/or vulnerable historic materials or locations.
 - Maintain existing building systems where they exist; shut-off exterior water spigots, piping, etc. if no longer needed. Clean and lubricate hinges, rolling doors/shutters, carousel, and other moving parts.

Recommendations: Contributing Resources

Contributing elements of the Pony Ride Site should be retained to the extent feasible and should undergo repair and maintenance (see above), as needed, in consideration of the specific recommendations provided below. Any future work proposed on contributing resources should be reviewed by a qualified historic architect to ensure conformance with the Standards.

Historic Vegetation

- An evaluation of the health and condition of historic trees was not within the scope of this HSR. ARG recommends that an arborist conduct a comprehensive evaluation regarding the condition of trees throughout the Pony Ride Site, particularly the coast live oak and coast redwood trees, which were present on the site during the period of significance (1947-1956) and thus contribute to its significance.

- When determining new plantings for the site, consider reinstating species (sycamore, elderberry, maple) that were identified in the 1956 “Griffith Park Pony Ride Area” site plan (see Appendix C: Historic Drawings).

Pergola

- Remove existing pipe brace at southwest corner, and perform repairs per structural report. Replace existing 2x8 members at each corner with new larger rafters. Provide temporary shoring until repairs can be made.
- Provide additional wood blocking between roof rafters per structural report; paint to match existing.
- Repair cracks at concrete column footings.
- Replace T-shaped steel plate connection between column and beam (1 location). Strengthen any other connections with new fasteners/hardware as required.
- During next roof replacement (approx. 10 years away), inspect sheathing boards thoroughly, and replace damaged boards as needed.
- Optional tasks:
 - Consider removing cable stand at roof and roofing over penetrations; electrical power could be re-routed underground.
 - Consider removing non-original shade structure at south side of building; this awning can be damaging to the historic roof and column framing during high wind events.
 - Non-original metal stanchions and directional markings may be removed if desired.
 - Wood benches and wood picket fence may be reinstated, per original drawings and historic photographs.
 - If desired, a historic finishes analysis may be conducted to determine original paint colors for future repainting work.

Ticket Booth

- Repair damaged asphalt shingles and re-seal around light pole penetration at north side of roof.
- Replace heavily decayed (rotted) wood rafter tails (end splice).
- Infill opening at east façade (old A/C unit opening) with new wood studs sistered to existing studs, and new vertical siding; paint to match.
- Remove existing plywood wainscot covering, and thoroughly inspect and document condition of horizontal siding concealed below; repair or replace siding boards and deteriorated wood stud framing as required.

- Repair existing wood sill above wainscot; infill notches, gouges, splits, and other damage with wood-compatible epoxy and repaint.
- Repair deterioration at base of porch columns with wood-compatible epoxy and repaint. Consider installing column base plate or other connection to raise wood above grade and prolong life of wood columns.
- Replace heavily deteriorated wood door and frame at north façade; new door should be of similar style using barn-door style trim and decorative surface-mounted hinges. Provide new hardware, including hinges, entry/lock set, and dead bolt.
- Repair existing ticket window at south façade; remove non-original hardware, repair gouges, splits and losses in wood shutters with wood-compatible epoxy fill, and repaint. Provide new hardware to lock opening securely, such as cane bolts top and bottom mounted at the interior.
- Clean interior to remove remaining abandoned items, trash, and debris.
- Repair damaged areas of existing interior wallboard (sheetrock) as rodent-proofing measure.
- During next roof replacement (approx. 10 years away), inspect sheathing boards thoroughly and replace damaged boards as needed.
- Depending on future use, rehabilitate interior finishes and furnishings.
- Optional tasks:
 - If desired, a historic finishes analysis may be conducted to determine original paint colors for future repainting work.

Riding Ring

- Re-grade and/or fill areas with large ruts or depressions to prevent standing water and improve site drainage.
- Secure underground concrete vault at north end of riding ring; vault may be backfilled if no longer used, or replace existing deteriorated wood cover with new locking vault door.
- Replace heavily decayed/rotted or termite-damaged wood posts with new to match (approx. 10% of total). Consider replacing with naturally rot- and insect-resistant wood species or preservative-treated lumber.
- Replace warped/sagging or otherwise deteriorated wood railings (approx. 10% of total).
- Replace corroded nails/fasteners at railings, and re-fasten where loose.
- Repaint guiderails and fences.
- Optional tasks:
 - Non-original shade structure and trough at northeast corner may be removed if desired.

- Non-original employee stand at light pole may be removed if desired.
- Running and buggy ride track fencing may be replaced and reconfigured to match original fencing, per original drawings and historic photographs.
- Track fencing may be replaced with taller fencing to accommodate a new use so long as the multi-track configuration and horseshoe shape is maintained.

Recommendations: Non-Contributing Resources

Non-contributing elements can be treated with greater flexibility in terms of alteration or removal within the Pony Ride Site. However, major changes, such as the addition of square footage, should be reviewed by a qualified historic architect to ensure compliance with the Standards as related to potential impacts to the historic character of the Pony Ride Site. Should the RAP choose to retain any of the following non-contributing resources, optional repair and maintenance recommendations have been provided to prolong their useful life.

Non-Historic Vegetation

- Non-historic tree species (those added after the Pony Ride Site's period of significance), including gold medallion, carrotwood, palm, and jacaranda, may be removed from the site, if desired.

Pony Sweep

- Remove heavy amounts of collected leaves and debris at roof covering, and trim overhanging trees.
- Provide lock at gate to prevent unauthorized entry and playing on carousel.
- Alternatively, because the structure is not historic and does not contribute to the historic significance of the Pony Ride Site, the pony sweep may be removed if no longer needed for future use.

Snack Stand and Restroom Building

- Repair large hole at north elevation CMU wall (rodent-proofing).
- Reattach sign in more permanent manner to prevent falling.
- Alternatively, because the building is not historic and does not contribute to the historic significance of the Pony Ride Site, the snack stand may be removed if no longer needed for future use.

Barn

- Clean existing corrugated metal roof and inspect for damage. Replace corroded sheets at eaves; seal over exposed fasteners; and seal all pinholes, gouges or penetrations.
- If desired for new use, remove urea stains/smells and salt deposits by excavating the earthen floor to a certain depth, and backfilling and compacting new soil.

- Undertake rodent-proofing measures, such as closing up holes in walls or ground around building, provided baited traps, etc.
- Alternatively, because the building is not historic and does not contribute to the historic significance of the Pony Ride Site, the barn may be removed if no longer needed for future use.

Corrals

- Because the corrals are not historic and do not contribute to the historic significance of the Pony Ride, they may be removed if no longer needed for future use.

Small-Scale Features

- Repoint stone masonry walls at planters, including cracks and separations. Replace missing brick paver units. Monitor for further stress or damage related to tree roots and reassess.
- Alternatively, as the planters are not historic/contributing to the significance of the Pony Ride, they may be removed if not needed for future use.
- The freestanding shade structure and birthday pavilions are not historic and may be removed if desired.

Bibliography

Agreement for the Operation and Maintenance of the Griffith Park Pony Ride Concession between the City of Los Angeles Department of Recreation and Park and Los Angeles Pony Rides, Inc. 2016.

“Bids Wanted.” *Los Angeles Times*, March 5, 1978.

Birnbaum, Charls A., ASLA, National Park Service, U.S. Department of the Interior. *Preservation Brief 36: Protecting Cultural Landscapes: Planning, Treatment and Management of Cultural Landscapes*. Washington, D.C.: National Park Service, 1994. Accessed August 2023.
<https://www.nps.gov/orgs/1739/upload/preservation-brief-36-cultural-landscapes.pdf>.

Board of Recreation and Park Commissioners. “Concession Agreement Between the City of Los Angeles and Thomas T. Wright.” June 28, 1979.

----- “Griffith Park Pony Ride Concession – Award of Contract to Los Angeles Pony Rides, Inc., Authorization to Develop Concession Agreement.” Board Report No. 16-108. May 4, 2016.

----- “Griffith Park Pony Ride Concession – Award of Contract to Los Angeles Pony Rides, Inc. (CON-M16-001).” Board Report No. 16-147. July 13, 2016.

----- “Griffith Park Pony Ride Concession – Proposal by Los Angeles Pony Rides, Inc. for the Construction of a Birthday Part Pavilion – Exemption from the California Environmental Quality Act (CEQA) Pursuant to Article III, Section 1, Class 3(3) and Class 11(6) of the City CEQA Guidelines.” Board Report No. 16-254. December 14, 2016.

----- “Griffith Park Pony Ride Concession Request for Proposals.” Report of General Manager No. 05-174. June 15, 2005.

Castillo, Edward D. “Short Overview of California Indian History.” *State of California Native American Heritage Commission*. Accessed August 2023. <https://nahc.ca.gov/resources/california-indian-history/#:~:text=About%20100%2C000%20or%20nearly%20a,managed%20to%20maintain%20tribal%20cohesion>.

City of Los Angeles. Economic Development and Jobs Committee Report, File No. 19-0781, July 1, 2022.

City of Los Angeles Department of Recreation and Parks. “Site Plan – Griffith Park Pony Ride.” September 1977.

Department of Parks, City of Los Angeles, Board of Park Commissioners. “Plot Plan of Pony Ride.” May 3, 1946.

Department of Recreation and Parks, Planning and Engineering Division, City of Los Angeles, California. “Roadway to Pony Stables: Pony Ride Area, Griffith Park.” September 1957.

Eberts, Mike. *Griffith Park: A Centennial History*. Los Angeles: Historical Society of Southern California, 1996).

- ESA. "Silver Lake Reservoir Complex Master Plan Project: Draft Environmental Impact Report." Prepared for City of Los Angeles Bureau of Engineering, Department of Public Works. October 2022.
- "Former Fairburians Have World's Largest Pony Ride Concession." *Fairbury Journal-News* (Fairbury, NE), March 11, 1954.
- "Frame Finder." Special Research Collections, UCSB Library, University of California Santa Barbara. Accessed August 2023. https://mil.library.ucsb.edu/ap_indexes/FrameFinder/.
- "Google Earth Pro." Accessed August 2023. <https://earth.google.com>.
- Greene, Sean and Thomas Curwen. "Mapping the Tongva Villages of L.A.'s Past." *Los Angeles Times*, accessed August 2023. <https://www.latimes.com/projects/la-me-tongva-map/>.
- "Griffith Construction Contract Awarded." *Los Angeles Evening Citizen News*, August 2, 1960.
- "Griffith Park Pony Ride Escapes Last Roundup." *Los Angeles Times*, February 15, 1986.
- "Historic Aerials." *NETRONLINE*. Accessed August 2023. <https://historicaerials.com/>.
- "History." *Gabrielino-Tongva Indian Tribe*. Accessed August 2023. <https://gabrielinotribe.org/history/>.
- ICF Jones & Stokes. Los Angeles Historic-Cultural Monument Application, "Griffith Park." 2008.
- Los Angeles Department of Recreation and Parks. Griffith Park Master Plan. 1968.
- "Mayor Tom Bradley." *Los Angeles Times*, February 14, 1986.
- Newberry, Laura. "Long-running Griffith Park Pony Rides to Close this Year." *Los Angeles Times*, December 5, 2022.
- "Park Board Gets Sketches of Proposed Griffith Park Railway." *Los Angeles Evening Citizen News*, December 28, 1946.
- "Ponies in Peril: Insurance Woes Threaten Griffith Park Ride." *Los Angeles Times*, February 11, 1986.
- "Pony Ride Concession." *Los Angeles Evening Citizen News*, August 9, 1957.
- "Pony Ride Robber Escapes with \$5,000." *Los Angeles Times*, July 16, 1991.
- Roche. "Griffith Park Pony Ride Area." Site Plan, April 14, 1956. Updated January 19, 1961.
- "Save the Pony Rides." *Los Angeles Times*, February 12, 1986.
- "Small Fry Find 'Old West' Still Lives." *Los Angeles Mirror*, June 25, 1953.
- "Take a Peek, Fellers, That New Pony's Here." *Los Angeles Mirror*, November 16, 1949.

Appendix A: Structural Report

Appendix B: Existing Conditions Drawings

Appendix C: Historic Drawings

Appendix D: Contributing and Non-Contributing Resource Maps

Griffith Park Pony Ride Facility Structural Condition Assessment



March 27, 2024

Prepared for

Architectural Resources Group
360 E. 2nd Street, Suite 225
Los Angeles, CA 90012

Prepared by

TYLin | Silman Structural Solutions
707 Wilshire Boulevard, Suite 4900
Los Angeles, CA 90017

Silman Project #3026.0030231

TABLE OF CONTENTS

Introduction	1
Building History	2
Investigation	3
Structural Description	6
Pergola	6
Ticket Booth	13
Riding Rings	16
Conditions Assessment	23
Pergola	23
Ticket Booth	24
Riding Rings	28
Probes & Testing	29
Analysis.....	30
Applicable Codes & Standards	30
Material Properties	30
Design Loads	30
Analysis Results	32
Recommendations.....	34
Pergola	34
Ticket Booth	36
Riding Rings	36

INTRODUCTION

The Griffith Park Pony Ride facility is a historic, 2.32-acre area of Griffith Park on Crystal Springs Drive in Los Angeles, California. Included in this facility is:

- An 8,000 square foot barn,
- Six outdoor corrals of various sizes,
- A fenced-in horseshoe shaped track with three separated lanes (known as the Riding Rings),
- A small pony ride sweep under a covered canopy,
- Two fenced birthday party and gathering areas,
- A 1,500 square foot solid wood canopy for queuing pony riders (known as the Pergola),
- A 225 square foot wood Ticket Booth,
- A snack bar.

Figure 1 shown below depicts the location and components of the facility as outlined above.

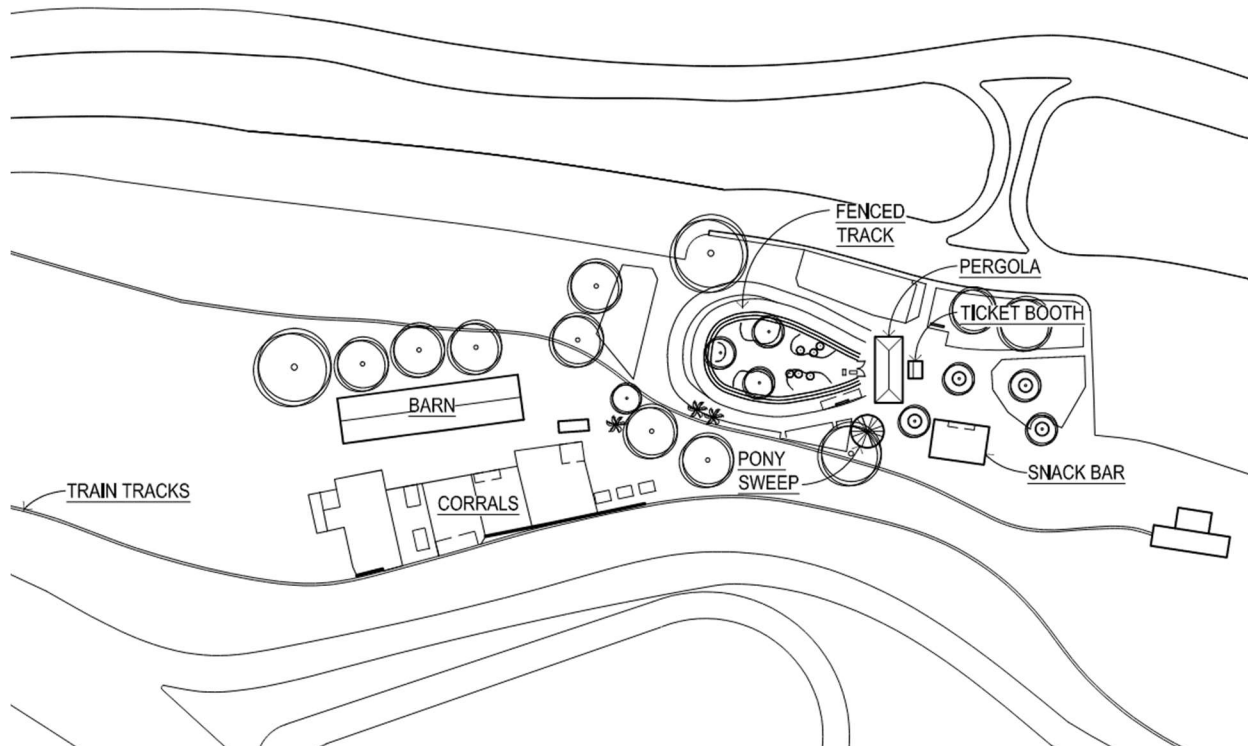

Figure 1 Site Plan of the Griffith Park Pony Ride Facilities (North Oriented Right)

Silman has been retained to perform a structural assessment of the Pergola, the Ticket Booth, and the horseshoe shaped track as part of the Griffith Park Pony Ride Historic Structures Report (HSR).

As part of the structural assessment, existing and new documentation was reviewed, and an on-site investigation was performed. On July 26th, 2023, Nathan Hicks and Amber Sutherland went to the site to better understand the facility structures, and their conditions. Based on the

provided documentation and observations made, Silman has identified conditions requiring repair, and recommendations to best protect and preserve each structure.

An outline of Silman’s specific services, and the purpose of the report herein, is provided below:

- Review of available documentation,
- Structural condition survey,
- Limited structural analysis for primary components, where existing structural information is available,
- Structural recommendations consistent with the building’s historic character for repairs,
- Identification of structural limitations and opportunities for future planned expansions and/or modernizations.

Building History

Limited documentation pertaining to the structural history of the Griffith Park Pony Ride Facility exists. The Pergola and Riding Rings were completed in 1947, the year the Pony Ride began operations. The Ticket Booth was added by 1952. The only noticeable structural change made since construction is the addition of steel tubes at the cantilevering roof of the Pergola (see **Figure 2**). It is unknown when this change was made. All other structural changes are unknown. Note that while this section focuses on the facility’s structural history, a general history can be found in the overall HSR.



Figure 2 Steel tubes that appear to have been added to the Pergola.

Investigation

The investigation herein is based on site observations, combined with a review of past photos and drawings made available to the design team. While on site, observations were made at both the interior and exterior of the structures. In general, the Pergola and Riding Rings were readily visible, and access was possible for almost all building areas. At the Ticket Booth, Silman could only observe some of the existing structure where finishes were not present.



Figure 3 Exterior view of the Ticket Booth showing the exterior finishes.



Figure 4 Interior view of the Ticket Booth showing the interior finishes.

Note that existing structural drawings were only provided for the Pergola. Based on what was observed on site, the Pergola framing is well documented, and aligns with the provided drawing noted below. All foundations were not accessible for review.

The following pertinent structural documentation was made available to the structural team at the time of the investigation:

- 1946 Department of Parks, City of Los Angeles drawing: includes a single sheet PDF with a plan view of the pony ride, and structural plans, elevations, and details of the Pergola.
- 1977 *Site Plan – Griffith Park Pony Ride* drawing by the City of Los Angeles, Department of Recreation and Parks: a single sheet PDF containing a plan view of the Griffith Park Pony Ride facilities.
- 1993 *Griffith Park Pony Ride Site Plan* by the Department of Recreation & Parks: a single sheet PDF outlining the key features of the Pony Park facility.
- 2008 *Historic-Cultural Monument Application* by Griffith J. Griffith Charitable Trust: a 350 page report including structural descriptions of the Ticket Booth, Pergola and Riding Rings.
- 2023 *Griffith Park Pony Ride – Assessment and Community Feedback Scope of Work*: includes a description and brief history of the Pony Ride facilities and grounds.

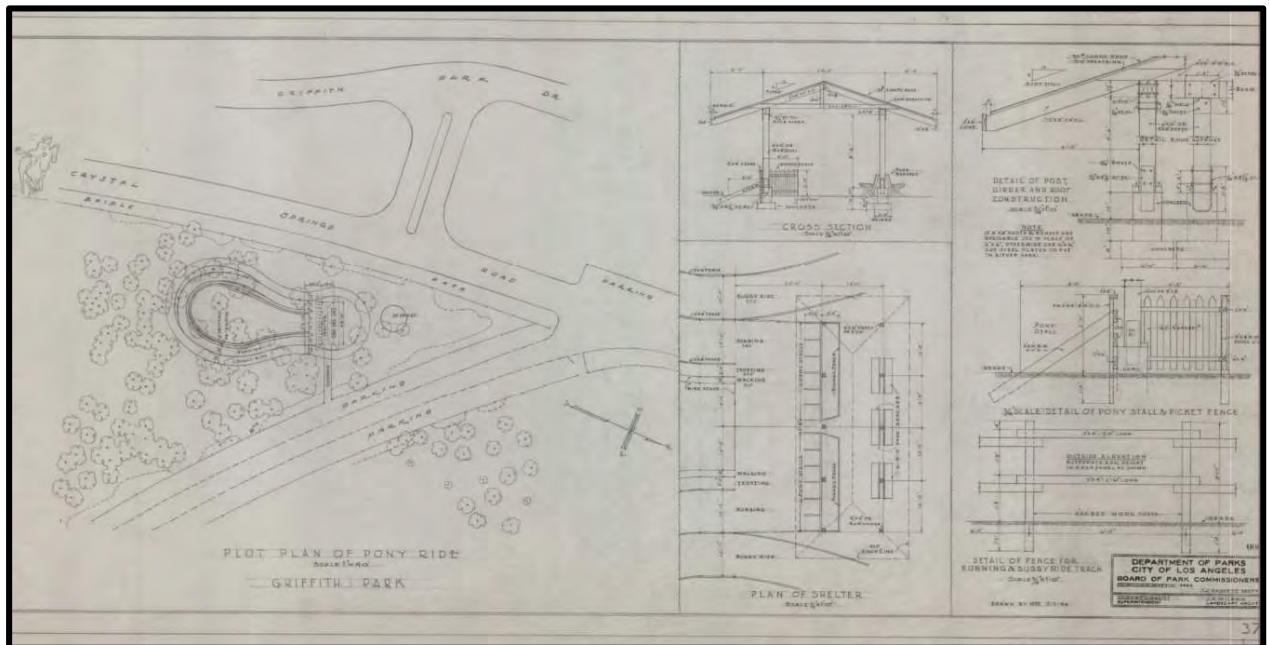

Figure 5 1946 Department of Parks, City of Los Angeles drawing of the Pergola.

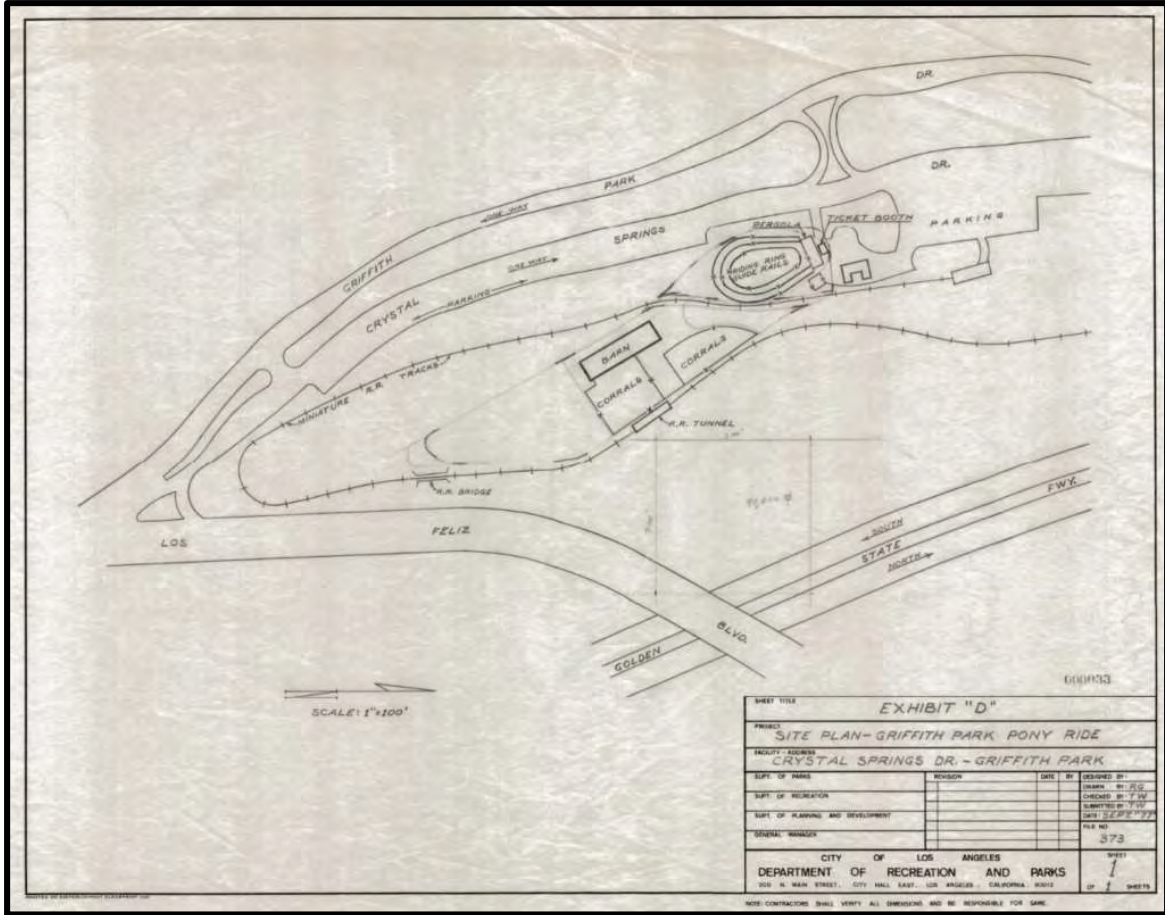

Figure 6 1977 Site Plan – Griffith Park Pony Ride drawing by the City of Los Angeles, Department of Recreation and Parks.

STRUCTURAL DESCRIPTION

Pergola

The Pergola is a single-story, open canopy composed of wood columns and roof framing. As shown in **Figure 7**, this structure is rectangular in shape with large roof overhangs at the perimeter.



Figure 7 View of the Pergola.

Foundation

Although the foundation was not accessible during Silman's site visit, based on the 1946 Department of Parks City of Los Angeles drawing of the Pergola, each column is embedded into a 1'-3" x 1'-3" x 1'-10" concrete column, that frames into a 2'-0" x 2'-0" x 0'-8" concrete pad footing (See **Figure 8** to **Figure 10**). It is unknown whether the footings contain reinforcing steel.

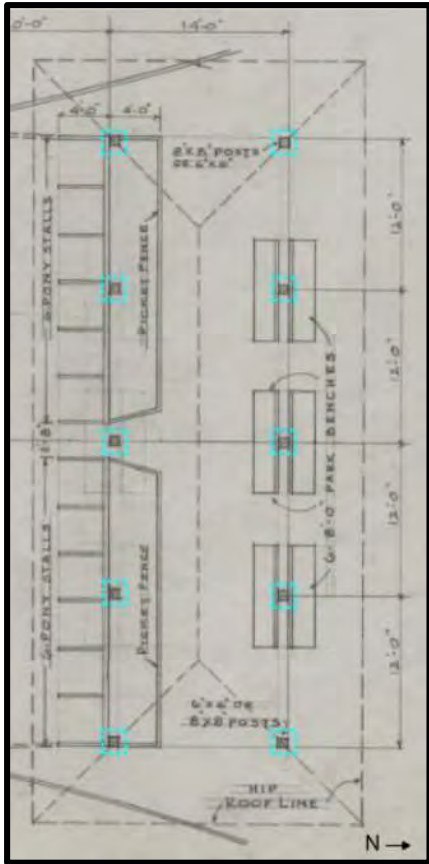

Figure 8 Plan view illustrating the locations of the Pergola column foundations (1946 Department of Parks, City of Los Angeles drawing of the Pergola).

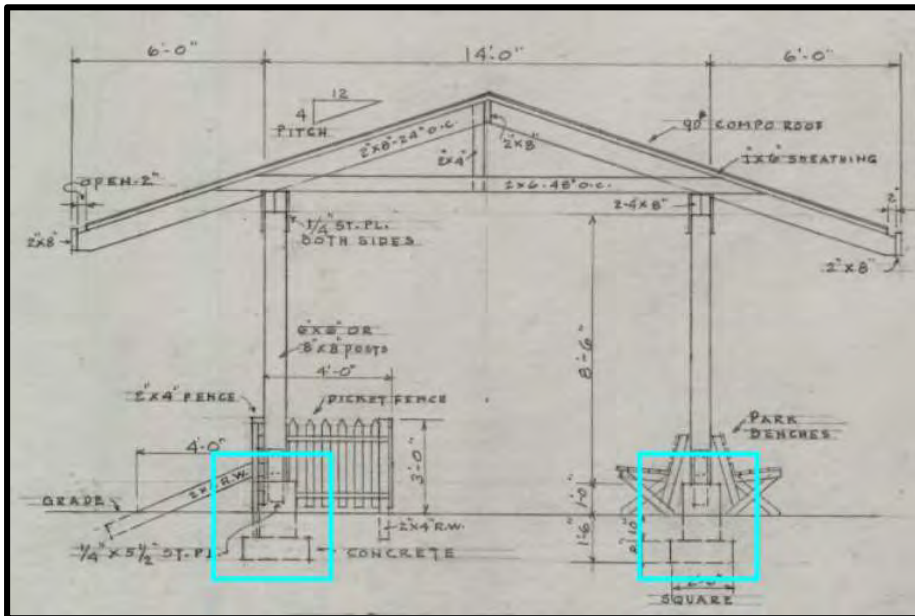

Figure 9 Section through the Pergola showing the assumed foundation (1946 Department of Parks, City of Los Angeles drawing of the Pergola).



Figure 10 View of the top of the foundation.

Columns

Ten equally spaced columns support the Pergola roof and serve as the lateral force resisting system. The corner columns are 8x8 (nominal) wood posts, while the interior columns are 6x6 (nominal) wood posts. See **Figure 11** for the location and size of each column.

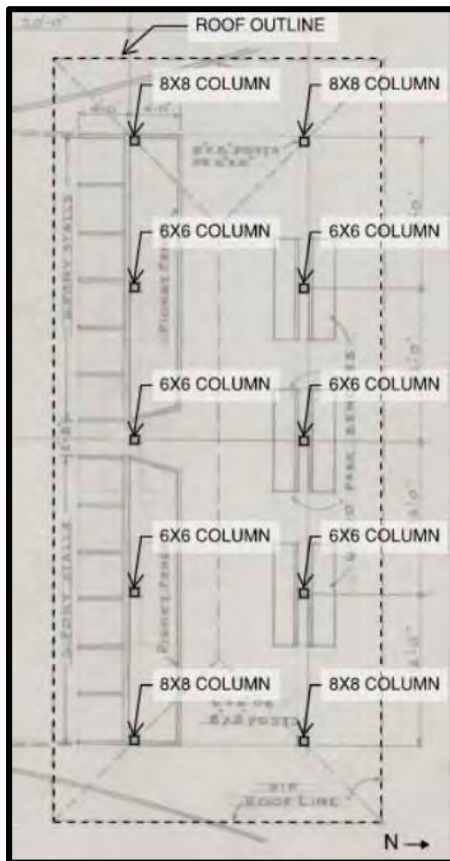

Figure 11 Plan view of the Pergola illustrating the column locations on the 1946 Department of Parks, City of Los Angeles drawing of the Pergola.

Roof Framing

The roof framing consists of north-south spanning 2x8 (nominal) rafters at 24 inches-on-center and 2x6 (nominal) collar ties at 48 inches-on-center (see **Figure 12**). Each rafter cantilevers 6'-0" beyond the columns as shown in **Figure 13**. The rafters support 1x6 (nominal) straight sheathing and asphalt shingles. Supporting the rafters are (2) 2.75"x8" wood beams spanning between the columns.

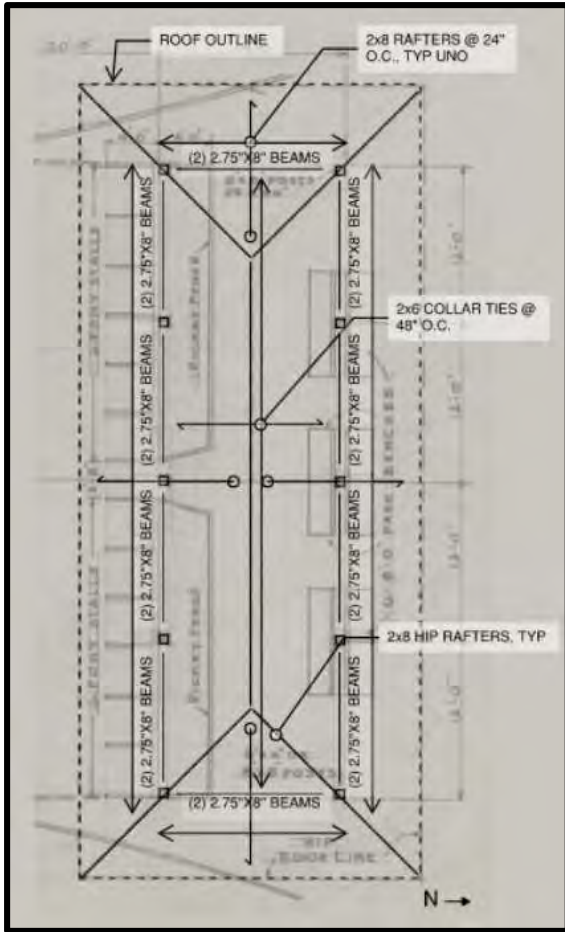

Figure 12 Plan view of the Pergola roof framing illustrated on the 1946 Department of Parks, City of Los Angeles drawing of the Pergola.

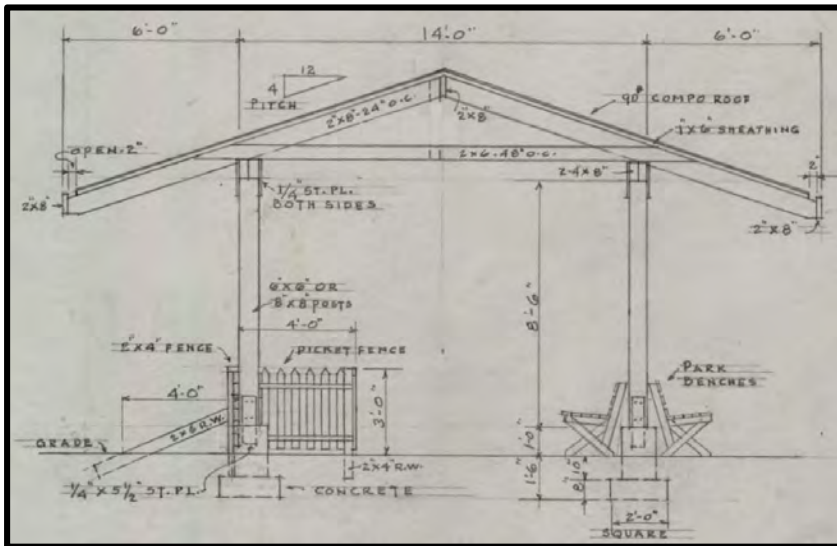

Figure 13 Section through the Pergola showing the roof framing from the 1946 Department of Parks, City of Los Angeles drawing of the Pergola.



Figure 14 View of the cantilevered roof rafter framing, beams and columns.



Figure 15 View of the Pergola roof collar ties, rafters, and beams.

Troughs & Posts

At the south side of the canopy are troughs spanning approximately 8'-6" between the columns, three feet above the ground. The troughs are composed of (2) 2x6 (nominal) beams and interior metal liner (see **Figure 16**).



Figure 16 View of the troughs at the south side of the canopy.

Adjacent to the troughs are 1/8" thick, 3.5" diameter steel posts at 8'-6" on center as shown in **Figure 17**.



Figure 17 View of the steel framing at the south side of the canopy.

Ticket Booth

The Ticket Booth is a single-story structure composed of wood bearing walls and wood roof framing. As shown in **Figure 18**, this structure is rectangular in shape with a roof overhang at the south elevation. Note that no drawings exist documenting the framing of the Ticket Booth. All structural descriptions are therefore based on observation of framing not covered by finishes.



Figure 18 View of the Ticket Booth.

Foundation

Due to inaccessibility, Silman could not observe the foundation for determination of material and constructed dimensions.

Exterior Walls & Columns

Four load bearing walls frame the Ticket Booth office and serve as the lateral force resisting system. Each wall appears to be 6 inches thick and composed of wood. The exterior faces of the walls have 1x8 (nominal) vertical siding on top. The bottom 40 inches of the walls are clad with horizontal wood siding, concealed beneath wood panels (see **Figure 19**). The panels were likely added at some point after the original construction.



Figure 19 Close up of the Ticket Booth top vertical siding and bottom wood panels.

At the south side of the Ticket Booth, four 4x4 (nominal) columns support the roof overhang (see **Figure 20**). Each column is approximately eight feet tall.



Figure 20 East elevation of the Ticket Booth showing the columns at the south.

See **Figure 21** for the locations of the walls and columns.

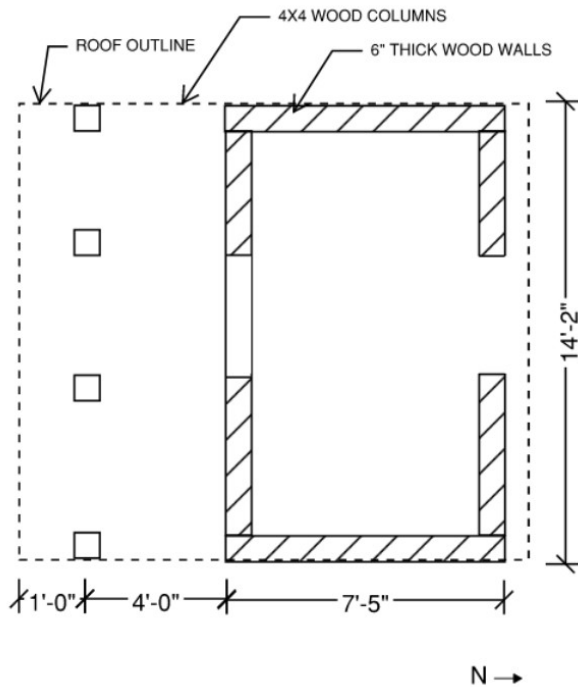

Figure 21 Plan view of the Ticket Booth columns and walls.

Roof Framing

The roof framing is largely obscured by ceiling finishes at the interior of the Ticket Booth. Based on the roof framing visible at the south overhang, it appears the roof consists of 1.5"x4" wood rafters at 24 inches-on-center (see **Figure 22**). Each rafter cantilevers over a 4x6 (nominal) wood beam. The rafters are connected to the wood beam via a 1-inch-deep notch at the base (see **Figure 23**).

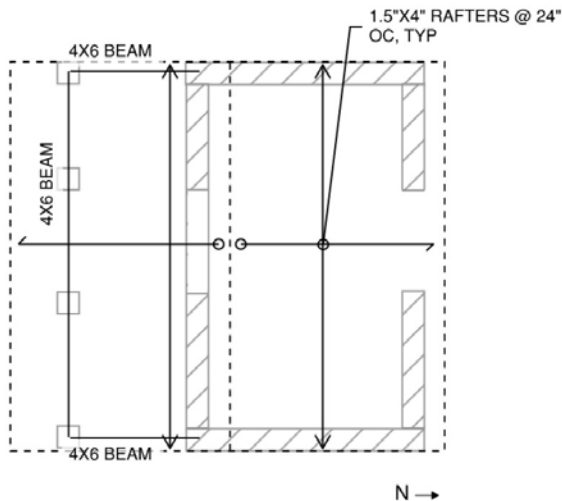

Figure 22 Plan view of the Ticket Booth roof framing.



Figure 23 View of the Ticket Booth roof framing at the south roof overhang.

Riding Rings

The Riding Rings are composed of Internal Guide Rails, a Running Guide Rail, a Buggy Guide Rail, a light post and a trench. Note that no structural drawings exist documenting the Riding Rings. All structural descriptions are therefore based on observations. A key plan has been provided below to help orient the reader.

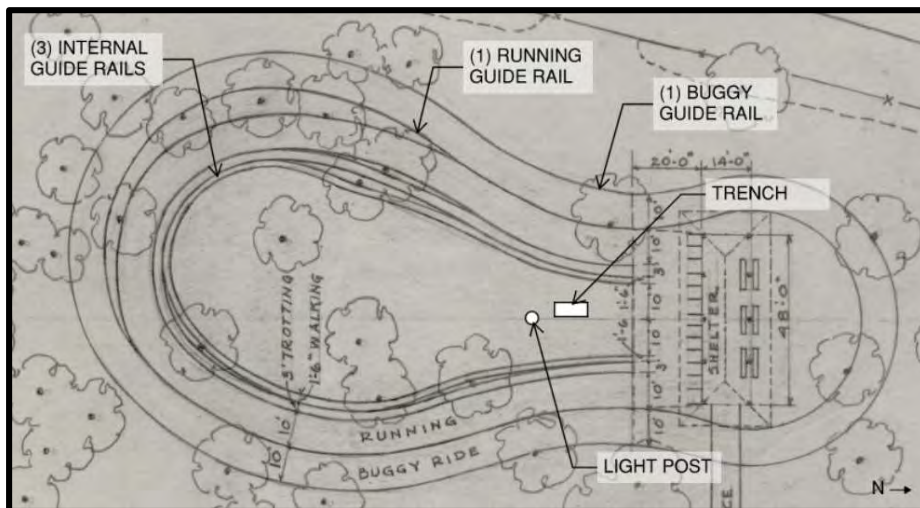

Figure 24 Site plan of the Riding Rings highlighting each element inspected.

Internal Guide Rails

The Internal Guide Rails consist of three horseshoe rings of wood posts and beams, spaced at approximately three feet-on-center (see **Figure 25**). Each ring is composed of wood posts and rails (see **Figure 26**). The 4x4 (nominal) wood posts are spaced at 8'-2" on-center and are about 14 inches tall. Spanning between the wood posts are 2x4 (nominal) rails. Two to three nails at each rail end connect the rail to the posts. Due to inaccessibility, Silman could not confirm if there is a foundation beneath the guide rails. Given the size and composition of the guide rail, it is likely the posts are simply embedded into the ground at an unknown depth.

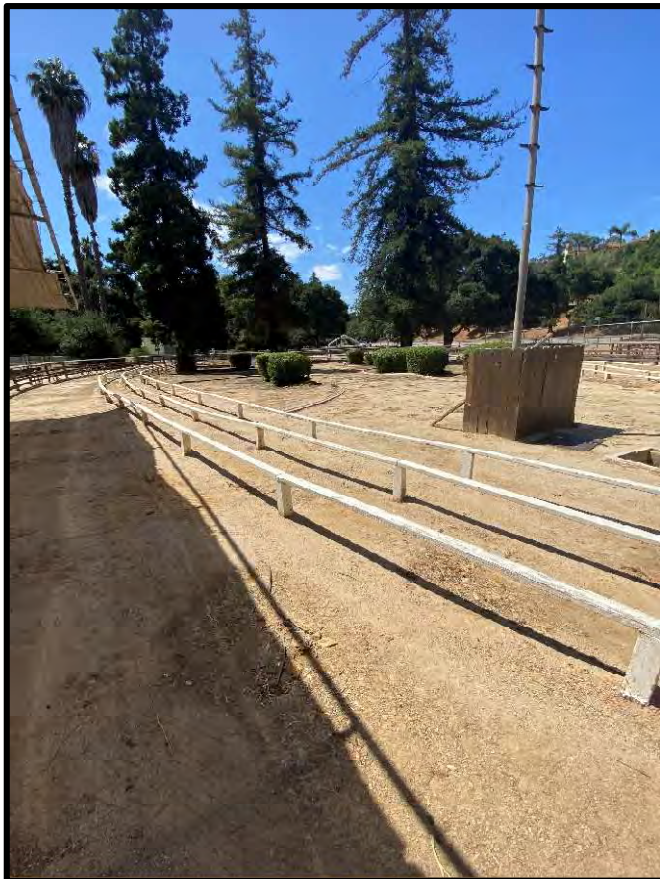

Figure 25 View of the Internal Guide Rails.



Figure 26 Close up of an Internal Guide Rail post and rail.

Running Guide Rail

Located ten feet away from, and surrounding the Internal Guide Rails, is the Running Guide Rail (see **Figure 27**). The Running Guide Rail consists of wood posts and rails. The wood posts have a 4x4 (nominal) cross section and are 2'-0" tall. At the top and bottom of the wood posts are 2x4 (nominal) rails spanning 8'-0" between wood posts (see **Figure 28**). Two nails at each rail end connect the rails to the posts. Due to inaccessibility, Silman could not observe if there is a foundation beneath the Running Guide Rail. Given the size and composition of the guide rail, it is likely the posts are simply embedded into the ground at an unknown depth.



Figure 27 View of the Running Guide Rail.



Figure 28 Close up of a Running Guide Rail post and rail.

Buggy Ride Guide Rail

Located 10 feet away from and surrounding both the Internal Guide Rails and the Running Guide Rail, is the Buggy Ride Guide Rail (see **Figure 29**). The Buggy Ride Guide Rail consists of wood posts and rails (see **Figure 30**). The wood posts have a 4x4 (nominal) cross section and are about 3'-2" tall. The posts have three rails at the top, middle and bottom that span seven feet on center. The bottom and middle rails have a 2x4 (nominal) cross section. The top rail has a 2x6 (nominal) cross section. Two nails at the end of each rail attach the rail to the post. Due to inaccessibility, Silman could not observe if there is a foundation beneath the Running Guide Rail. Given the size and composition of the guide rail, it is likely the posts are simply embedded into the ground at an unknown depth.



Figure 29 View of the Buggy Ride Guide Rail.



Figure 30 Close up of the Buggy Ride Guide Rail post and rail.

Light Post

Located within the Internal Guide Rails is an approximately 20-foot-tall light post (see **Figure 31**). The light post is composed of a four-inch diameter steel pole. This pole looks to be embedded in a circle, concrete foundation (see **Figure 32**). The depth and reinforcing of the concrete foundation could not be observed and is therefore unknown.



Figure 31 View of the light post.



Figure 32 View of the light post foundation.

Trench

Near the light post is a 28"x72" trench opening. The interior of the trench is composed of concrete. In between the concrete walls of the trench, wood boards slope downward (see **Figure 33**).



Figure 33 View of the trench.

CONDITIONS ASSESSMENT

A conditions assessment of the Pergola, Ticket Booth and Riding Rings has been performed by Silman to characterize the structure and identify current conditions. During our visit, detailed photo documentation of the building was completed to understand the identified conditions.

Pergola

Overall, the Pergola appeared to be moderately deteriorated. While the columns, rafters and collar ties looked to be in good condition, the items below will need to either be replaced or repaired, as specified in the Recommendations portion of the report.

Straight Board Sheathing

Deterioration of the straight sheathing spanning between the rafters was observed (see **Figure 34**). The wood is likely deteriorating due to exposure to temperature changes, water damage and insect damage.

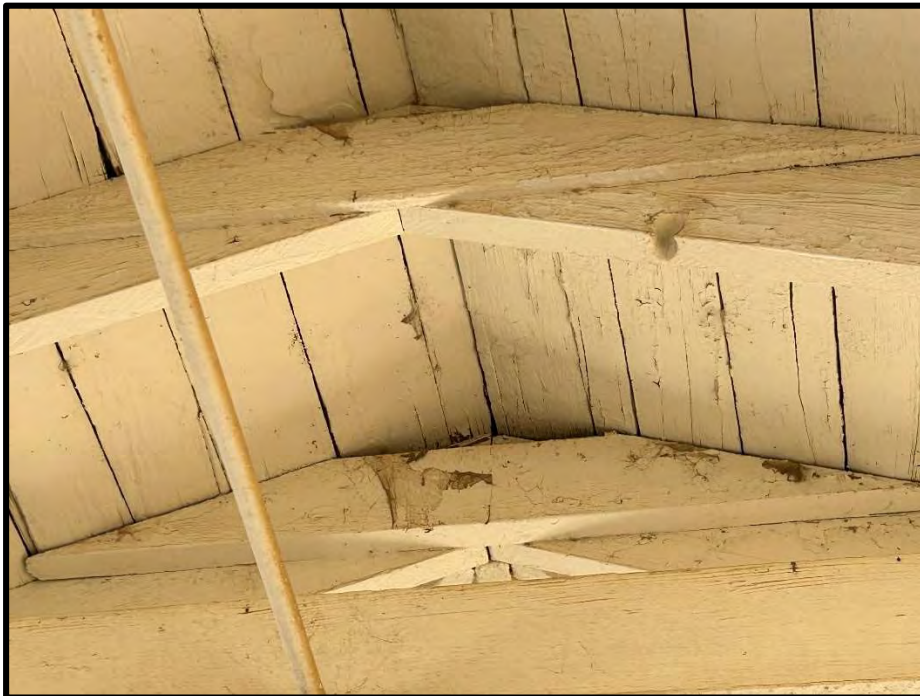

Figure 34 View of straight board sheathing deterioration.

Cantilevered Corners of Roof Framing

Each corner of the Pergola appears to be deflecting (see **Figure 35**). It appears the south-west corner was retrofitted with a steel pipe as highlighted in **Figure 2**. This does not meet the structural code requirements and will need to be removed.



Figure 35 View of the Pergola roof corners deflecting.

Ticket Booth

Overall, the Ticket Booth appeared to be in good condition, apart from a few items noted in the following locations.

Horizontal and Vertical Wood Siding

Both the ends of the vertical wood siding, and most of the horizontal siding located beneath the wood panels, are deteriorated (see **Figure 36** & **Figure 37**). This is likely due to water and insect damage over time.



Figure 36 Close up of the top of the wood panels concealing the horizontal siding.



Figure 37 Close up of the deteriorated, original horizontal siding.

Rafters

A few of the exposed rafter ends at the north and south faces of the Ticket Booth have deteriorated due to insect and water damage (see **Figure 38**).



Figure 38 View of the roof rafter deterioration at the ends of the member.

West Wall

At the West Wall, a 3'x2' opening looks to be improperly patched with a thin wood board (see **Figure 39**).



Figure 39 View of the improperly patched opening at the west wall of the Ticket Booth.

Base of Columns

At the base of the columns, some of the wood appears to be deteriorating due to biological growth and insect damage (see **Figure 40**).



Figure 40 View of minor biological growth and insect damage at the base of the Ticket Booth columns.

Riding Rings

Overall, the Riding Rings appeared to be in good condition, apart from the few items noted in the following locations.

Posts & Rails

While most of the wood at all the posts and rails looked to be in good condition, approximately 15 percent is deteriorated. This was especially noticeable at the post and rail ends, where chunks of the wood have fallen off (see **Figure 41**). This deterioration is likely caused by water and insect damage.



Figure 41 View of significant wood deterioration at the Internal Guide Rails.

Connections

Several connections between the Guide Rail posts and rails looked to be significantly deteriorated. At numerous locations, nails have fallen out and are missing (see **Figure 42**).



Figure 42 Deteriorated connection at the Internal Guide Rails.

PROBES & TESTING

No probes or testing was performed as a part of this project scope. Silman recommends that wood material testing be performed at a future date to confirm the analysis outlined in the following section.

ANALYSIS

This section includes a preliminary analysis of the existing roof framing at the Pergola, in addition to outlining the governing codes, material property assumptions, and design load assumptions used within the analysis, and to characterize the other structures composing the Griffith Pony Ride Facility.

Applicable Codes & Standards

This project will be governed by the following code:

- 2023 City of Los Angeles Building Code
- 2022 California Historic Building Code

The following standards will be followed as specified by the governing codes:

- ASCE 7-16 Minimum Design Loads (and Associated Criteria) for Buildings and Other Structures
- NDS-2018 National Design Specification (NDS) for Wood Construction

Material Properties

The material properties below are based on conservative lower end values appropriate for the time of construction. These properties are appropriate for the framing at the Riding Ring, Ticket Booth, and Pergola. Material testing is recommended to refine both the material values, and the corresponding Pergola analysis results.

Timber

The existing timber is assumed to be Douglas Fir-Larch #1. Douglas Fir-Larch #1 has the following material properties:

- | | |
|--|-----------------------------|
| • Allowable Bending Stress | $F_b = 1,000 \text{ psi}$ |
| • Allowable Tensile Stress (Parallel to Grain) | $F_t = 675 \text{ psi}$ |
| • Allowable Shear Stress | $F_v = 180 \text{ psi}$ |
| • Allowable Compressive Stress (Parallel to Grain) | $F_c = 1,500 \text{ psi}$ |
| • Modulus of Elasticity | $E = 1,700,000 \text{ psi}$ |

Design Loads

The loads presented below assume the Pergola and Ticket booth are Risk Category II, and the Riding Ring is Risk Category I (ASCE 7-16, Table 1.5-1).

Dead Loads

- Wood Roof Framing (Pergola & Ticket Booth) = 5 PSF

Live Loads

The following live load values are specified by the applicable codes and standards:

Occupancy or Use	Minimum Required Design Live Loads
Typical Roof (at the Pergola and Ticket Booth)	Per ASCE 7-16, Table 4.3.1, typical roofs are designed for a uniform load of 20 psf.
Handrails (at the Riding Rings)	Per ASCE 7-16, Section 4.5.1 and Section 4.5.1.1, handrails are designed to resist a single, 200 lb concentrated point load in any direction and at any point and a 60 plf uniform load applied in any direction at any point. The handrail does not need to be designed for these forces acting concurrently.

Wind Loads

- Basic Wind Speed V = 95 mph
- Wind Directionality Factor (ASCE 7-16, Table 26.6-1) $K_d = 0.85$
- Exposure Category (ASCE 7-16, §26.7) B
- Topographic Factor (ASCE 7-16, §26.8) $K_{zt} = 1.0$
- Ground Elevation Factor (ASCE 7-16, Table 26.9-1) $K_e = 1.0$
- Gust Effect Factor (ASCE 7-16, §26.11) G = 0.85
- Enclosure Classification (ASCE 7-16, §26.12, Pergola) Open
- Enclosure Classification (ASCE 7-16, §26.12, Ticket Booth) Enclosed
- Internal Pressure Coefficient (ASCE 7-16, Table 26.13-1) $GC_{pi} = 0$
- Velocity Pressure Coefficient (ASCE 7-16, §26.10.1) $K_z = .57$
- Velocity Pressure (ASCE 7-16, Eqn. 26.10-1, Pergola & Ticket Booth) $q_z = 12$ psf
- Net Pressure Coefficient (ASCE 7-16, Figure 30.7-2) CN = 1.2
- Component & Cladding Pressure at Roof Corners (ASCE 7-16, Eqn. 30.7-1) p = 13 psf

Seismic Loads

All parameters dependent on soil shall be confirmed by a geotechnical engineer. The seismic force-resisting system has been assumed to be cantilevered columns at the Pergola, and wood shear walls at the Ticket Booth.

- Soil Site Class (Assumed) D
- Short Period Mapped Spectral Accel. (ATC Hazards by Location) $S_s = 2.131$ g
- One Second Period Mapped Spectral Accel. $S_1 = 0.755$ g

(ATC Hazards by Location)

- Short Period Design Spectral Acceleration $S_{DS} = 1.705 \text{ g}$
(ATC Hazards by Location)
- Seismic Importance Factor (ASCE 7-16, Table 1.5-2) $I_e = 1.0$
- Response Modification Factor (ASCE 7-16, Table 12.2-1, Pergola) $R = 1.5$
- Seismic Response Coefficient (ASCE 7-16, Eqn. 12.8-2) $C_s = 1.14\text{g}$

Analysis Results

Live Load Capacities

A preliminary live load capacity analysis was performed for the Pergola roof framing members using analytical modeling. The analysis results indicate only some members meet the current code requirement for dead load and live load (20psf capacity). The members that do not meet the code requirement for dead and live applied loads are shown in red in **Figure 43** below.

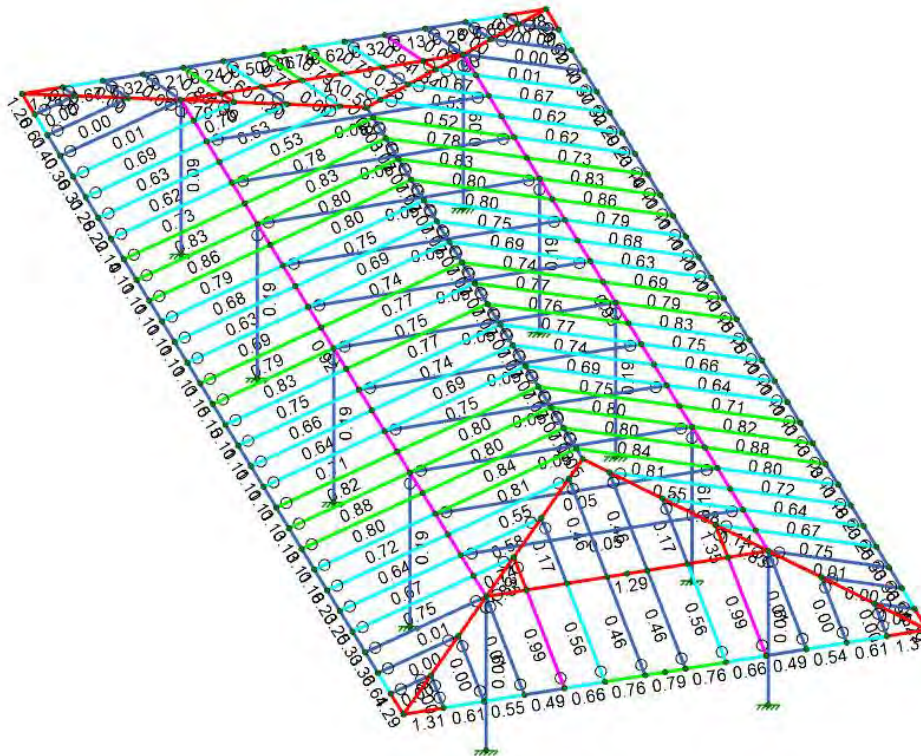

Figure 43 Analytical model of the Pergola showing which members are overstressed.

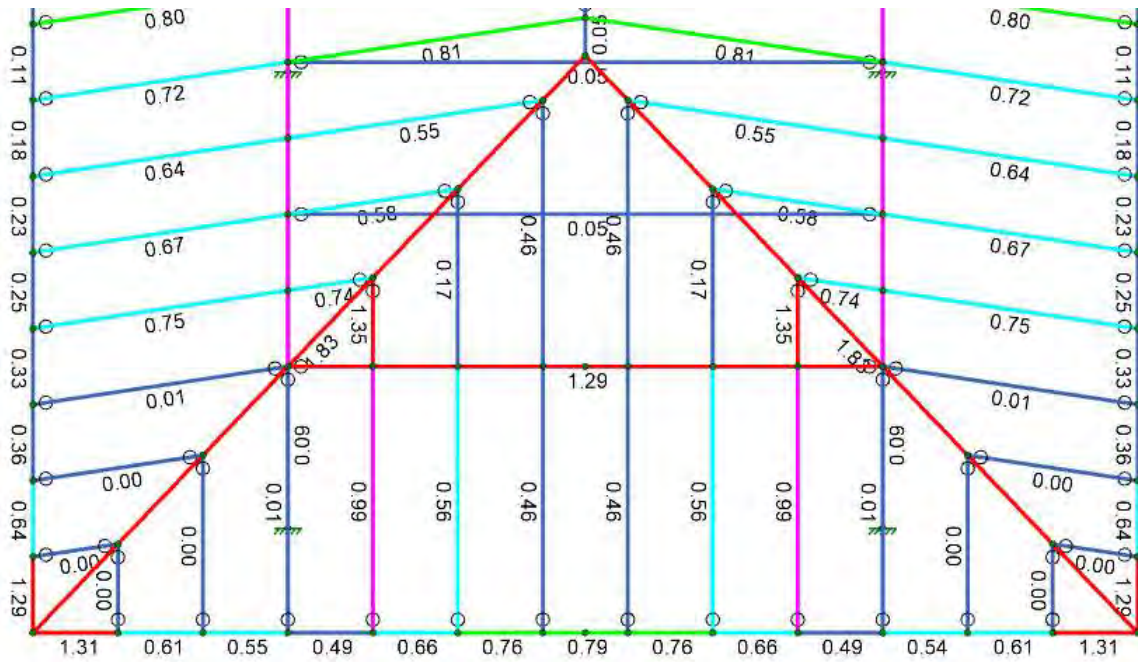

Figure 44 Close up of the analytical model showing the hip rafters are 83 percent overstressed.

As shown in **Figure 44** above, the hip rafters are approximately 83 percent overstressed. This aligns with what was observed on-site, where some of the hip rafters appeared to be deflecting. No evidence of overstress was observed at the beam supporting the roof rafters (marked as the 1.29 member in red in **Figure 44** above). It is therefore likely that the material strength assumptions made do not align with the actual properties of the wood material. Material testing is recommended to refine all analysis results.

Lateral Load Assessment

While the structure may have been designed for wind loads, a high-level review of the members indicates the framing may be able to handle seismic loads. A preliminary review of the connections indicates they are likely adequate. Further analysis is recommended to confirm.

RECOMMENDATIONS

The recommendations herein are based on site observations and subsequent structural analysis. As mentioned previously, field observations were limited to readily visible elements, since the site visit did not include removal of any finishes or destructive probes.

Overall, the Pergola structural repairs should be prioritized and occur as soon as possible. Repairs to the Ticket Booth are of intermediate priority and should be addressed in an approximate 3-year timeframe. Repairs to the Riding Ring are of the lowest priority and could be addressed in a 5-year timeframe. As part of future repairs wood species identification is recommended as it will help to refine material property assumptions and future repair specifications.

Pergola

As indicated by the analysis section of the report, the cantilevering hip rafters are failing. Silman recommends replacing the existing 2x8 (nominal) members with new, larger rafters (see **Figure 45** for locations). In the temporary condition it is recommended that shoring posts be installed below the four corners until repairs can be made.

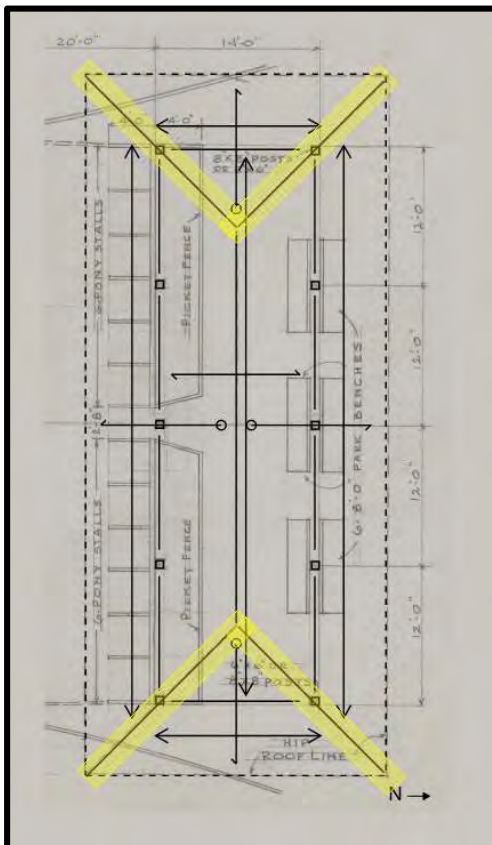

Figure 45 Plan view of the Pergola roof highlighting which members should be replaced with larger framing (illustrated on top of the 1946 Department of Parks, City of Los Angeles drawing of the Pergola).

Given the large spans of the roof rafters, Silman also recommends adding blocking between each rafter to provide additional structural stability (as shown in **Figure 46** below).

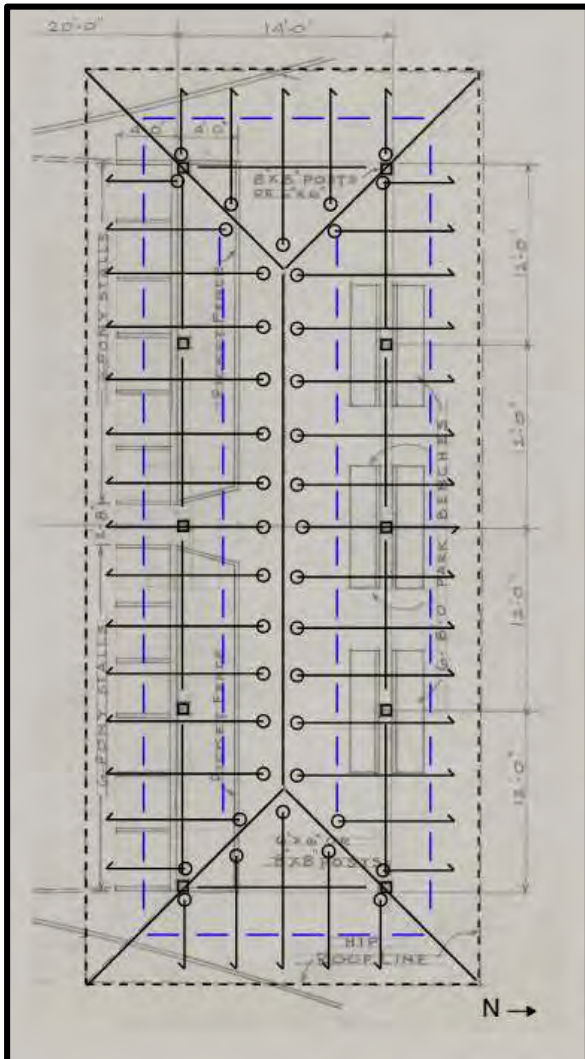

Figure 46 Plan view of the Pergola roof framing showing the potential location of blocking (illustrated on the 1946 Department of Parks, City of Los Angeles drawing of the Pergola).

In general, a portion of the straight wood sheathing appeared to be deteriorated. Silman recommends the wood be cleaned and repainted. During re-roofing all boards that are split, rotted and/or damaged should be replaced. Overlaying the straight board sheathing with plywood does not appear to be required but would help to improve the seismic performance. This would need to be balanced against the weight the plywood would add. Even this minimal increase could result in additional members stressed beyond their capacity for gravity loads.

While all not connections have been reviewed in this preliminary analysis it should be assumed that some will require strengthening with new fasteners/hardware.

Ticket Booth

At the west wall of the ticket booth, a 3'x2' opening has been improperly repaired (see **Figure 39** and **Figure 47**). Silman recommends closing this opening by adding in new studs to sister the existing studs and attaching new siding to match the existing siding.

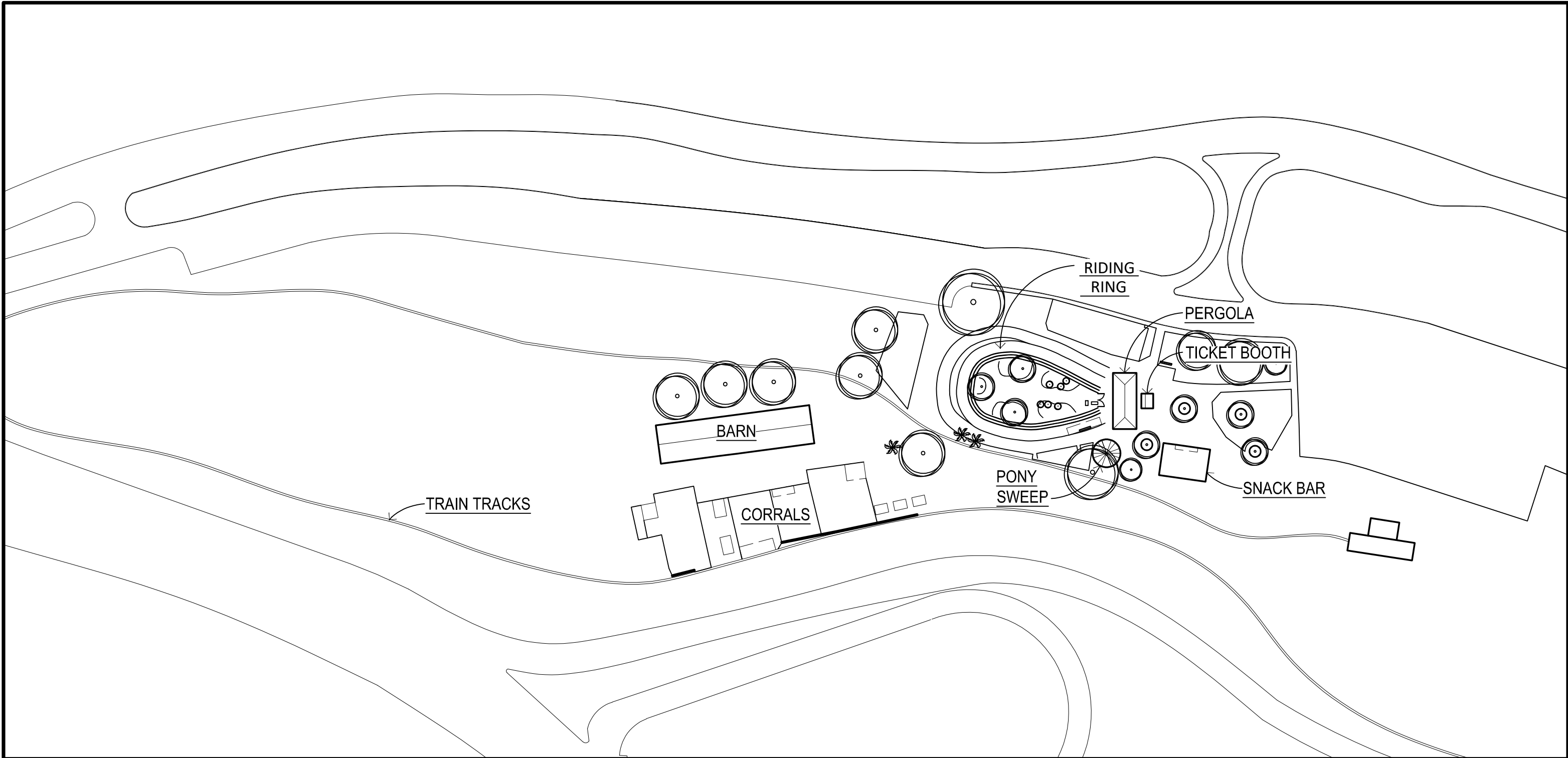

Figure 47 Interior view of the opening in the west wall of the Ticket Booth.

At the exterior of the ticket booth, wood deterioration was observed at the rafter ends, base of the columns and on the original horizontal siding concealed beneath the wood panels. All wood minorly deteriorated should be cleaned and painted. All significantly deteriorated wood should be replaced in kind. To address the deterioration of the original horizontal siding (see **Figure 37**), Silman recommends removing the exterior wood panels to expose the wood beneath.

Riding Rings

Several areas of significant wood deterioration were observed at the railing. Silman recommends addressing the deterioration by replacing approximately 10 percent of the wood in kind. Additionally, all wood should be cleaned and painted, and all fasteners should be replaced. Where wood framing in contact with ground is replaced, it should utilize a naturally rot-resistant species or PT lumber.



CONTEXT SITE PLAN

1" = 100'-0"



Architectural
Resources Group

GRIFFITH PARK PONY RIDE

AS-BUILT DRAWINGS
4400 CRYSTAL SPRINGS DRIVE, LOS ANGELES, CA
3/27/2024

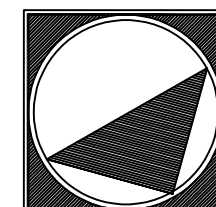

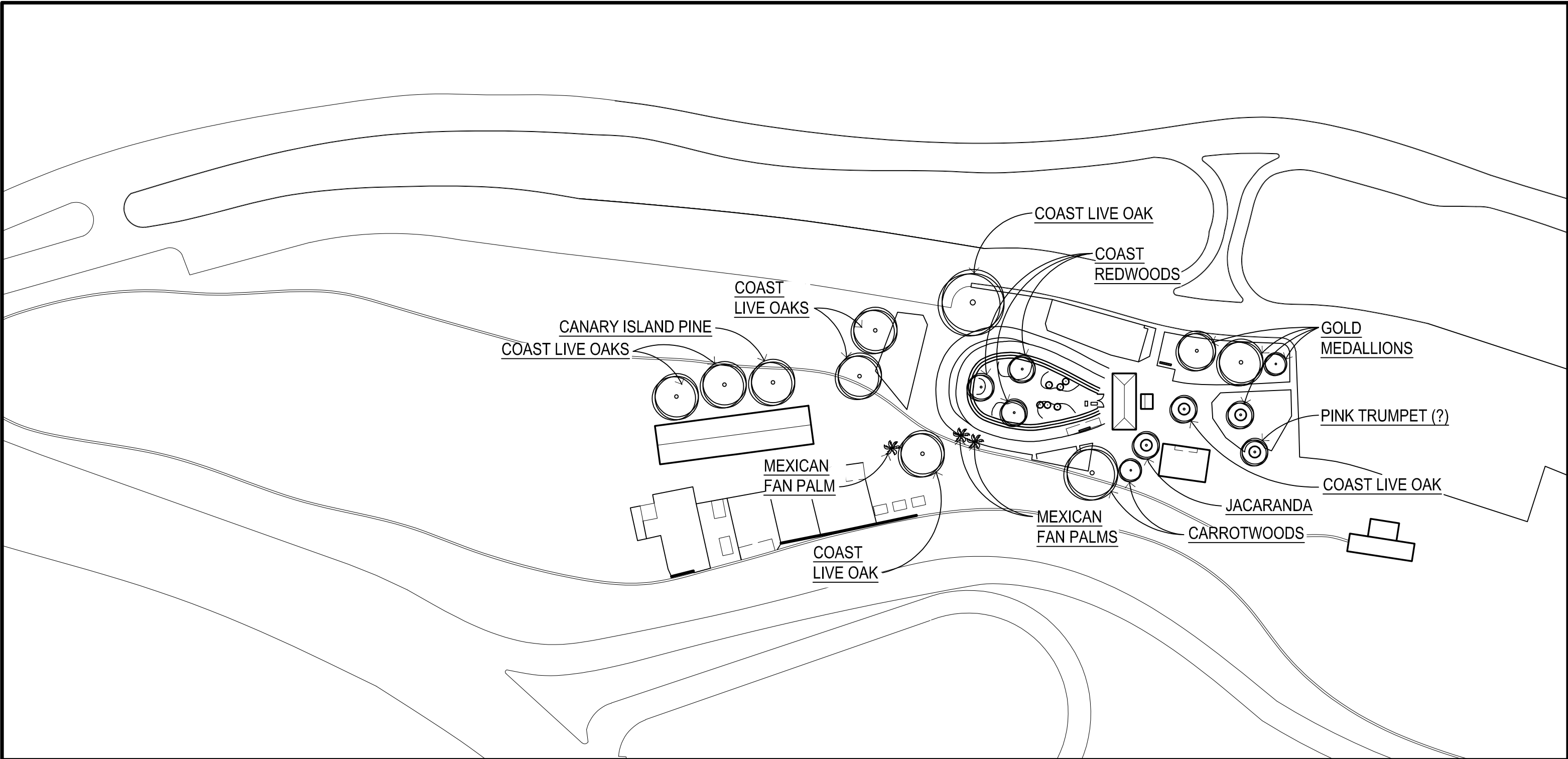

TREE IDENTIFICATION SITE PLAN

1" = 100'-0"



Architectural
Resources Group

GRIFFITH PARK PONY RIDE

AS-BUILT DRAWINGS
4400 CRYSTAL SPRINGS DRIVE, LOS ANGELES, CA
3/27/2024

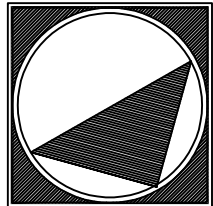

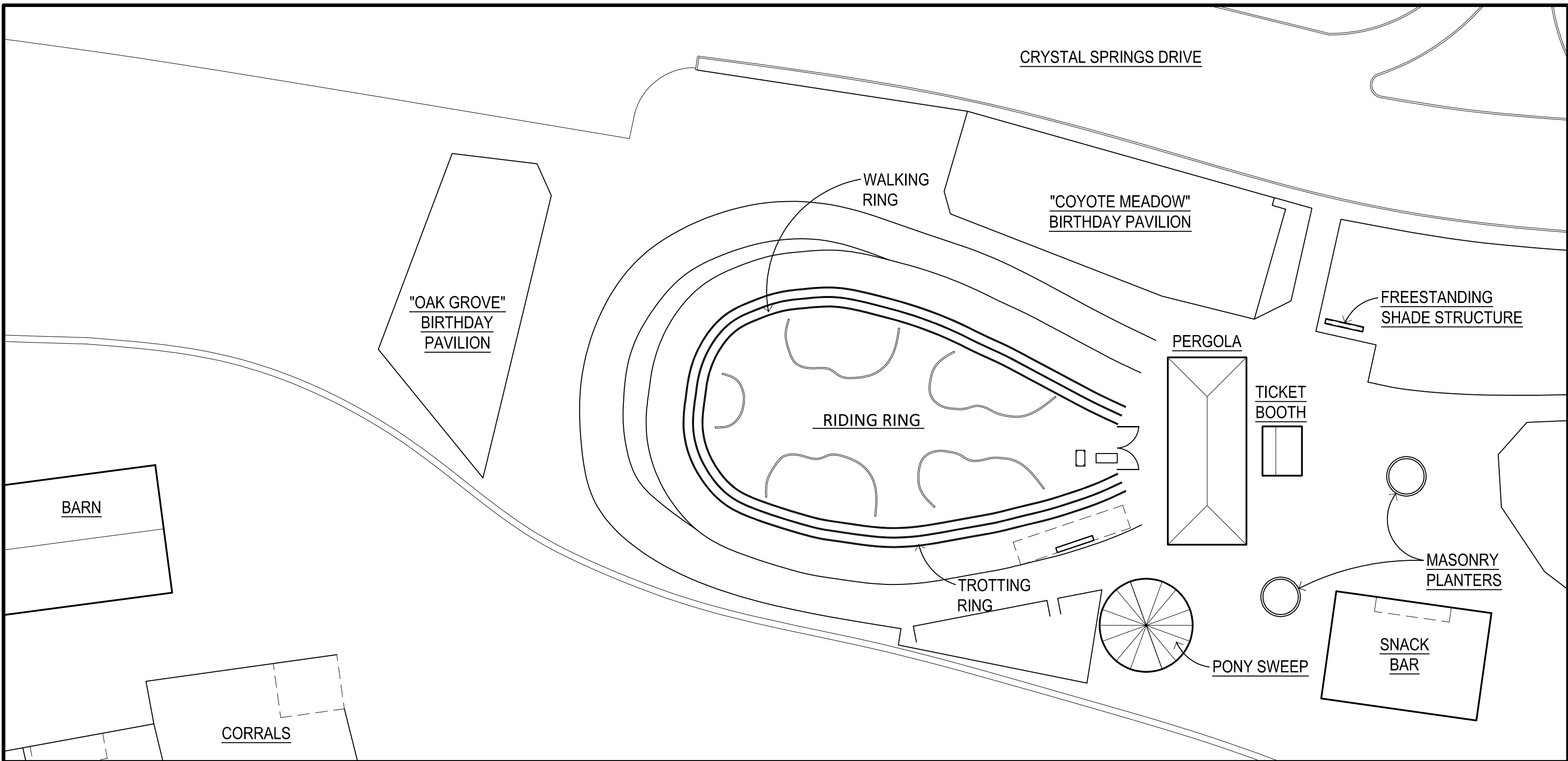

SITE PLAN

1" = 30'-0"



Architectural
Resources Group

GRIFFITH PARK PONY RIDE

AS-BUILT DRAWINGS
4400 CRYSTAL SPRINGS DRIVE, LOS ANGELES, CA
3/27/2024

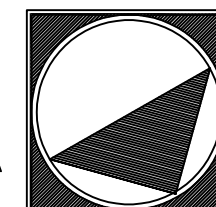

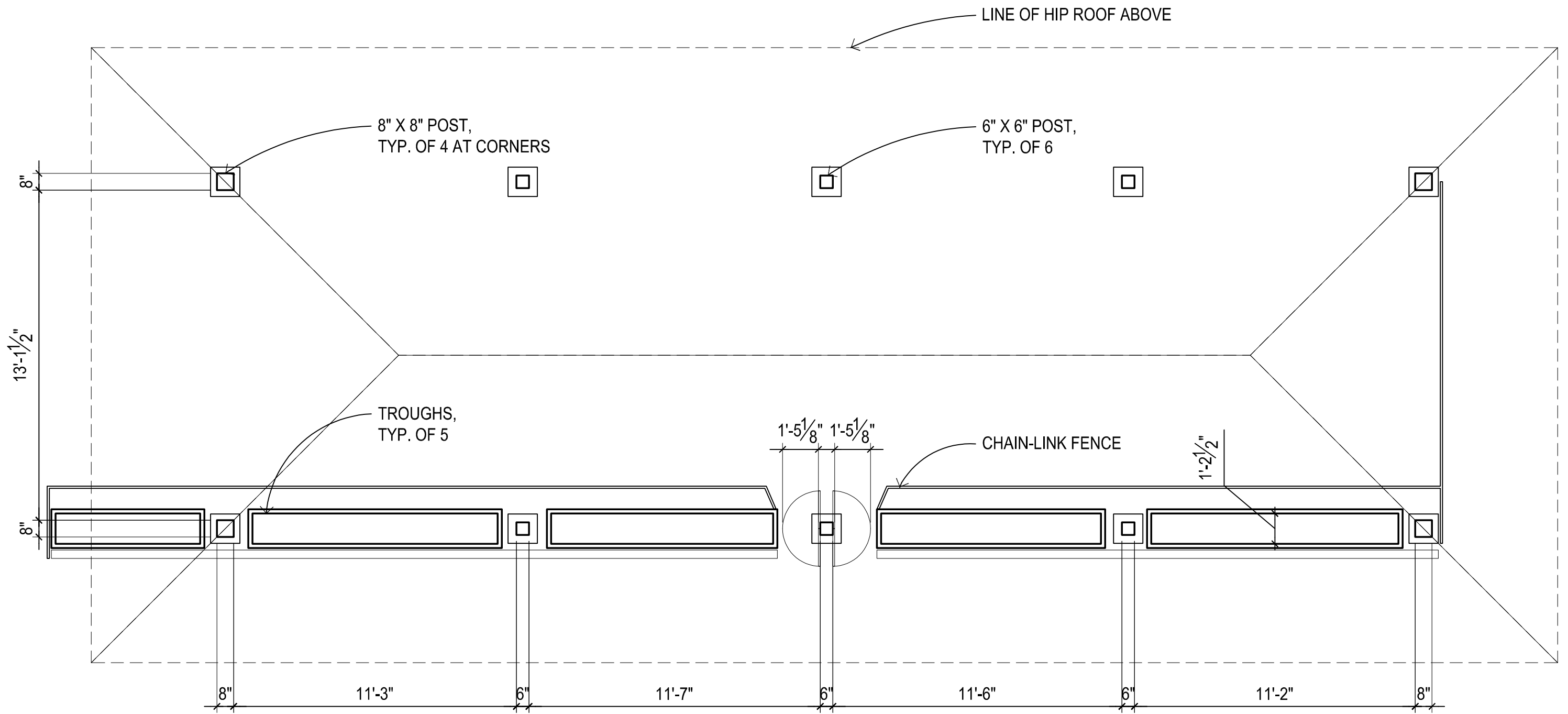

FLOOR PLAN - PERGOLA

1/4" = 1'-0"



Architectural
Resources Group

GRIFFITH PARK PONY RIDE

AS-BUILT DRAWINGS
4400 CRYSTAL SPRINGS DRIVE, LOS ANGELES, CA
3/27/2024

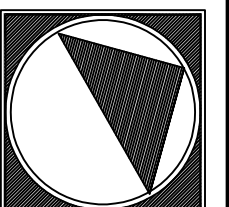

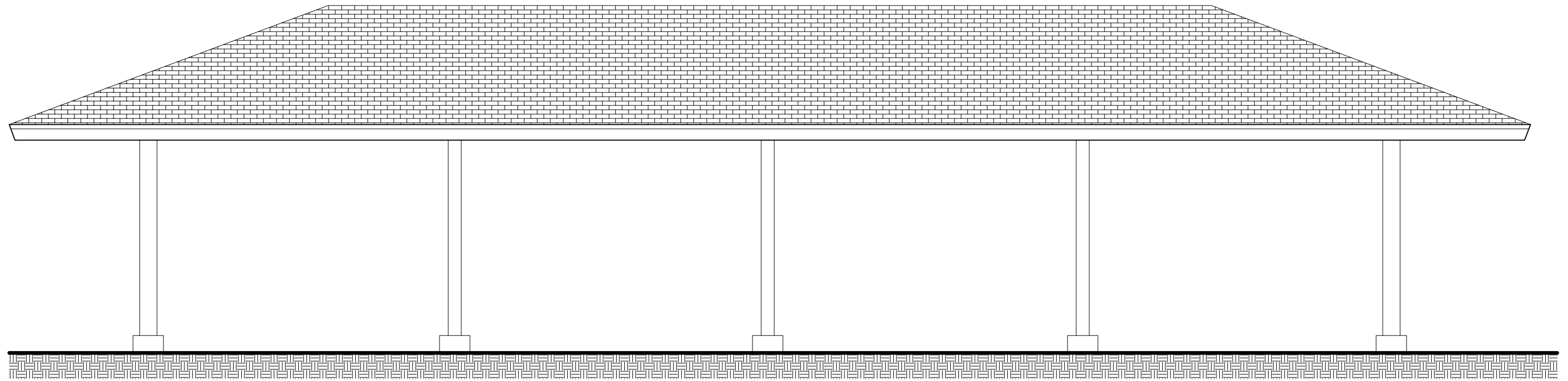

EXTERIOR ELEVATION - PERGOLA - NORTH

1/4" = 1'-0"



Architectural
Resources Group

GRIFFITH PARK PONY RIDE

AS-BUILT DRAWINGS
4400 CRYSTAL SPRINGS DRIVE, LOS ANGELES, CA
3/27/2024

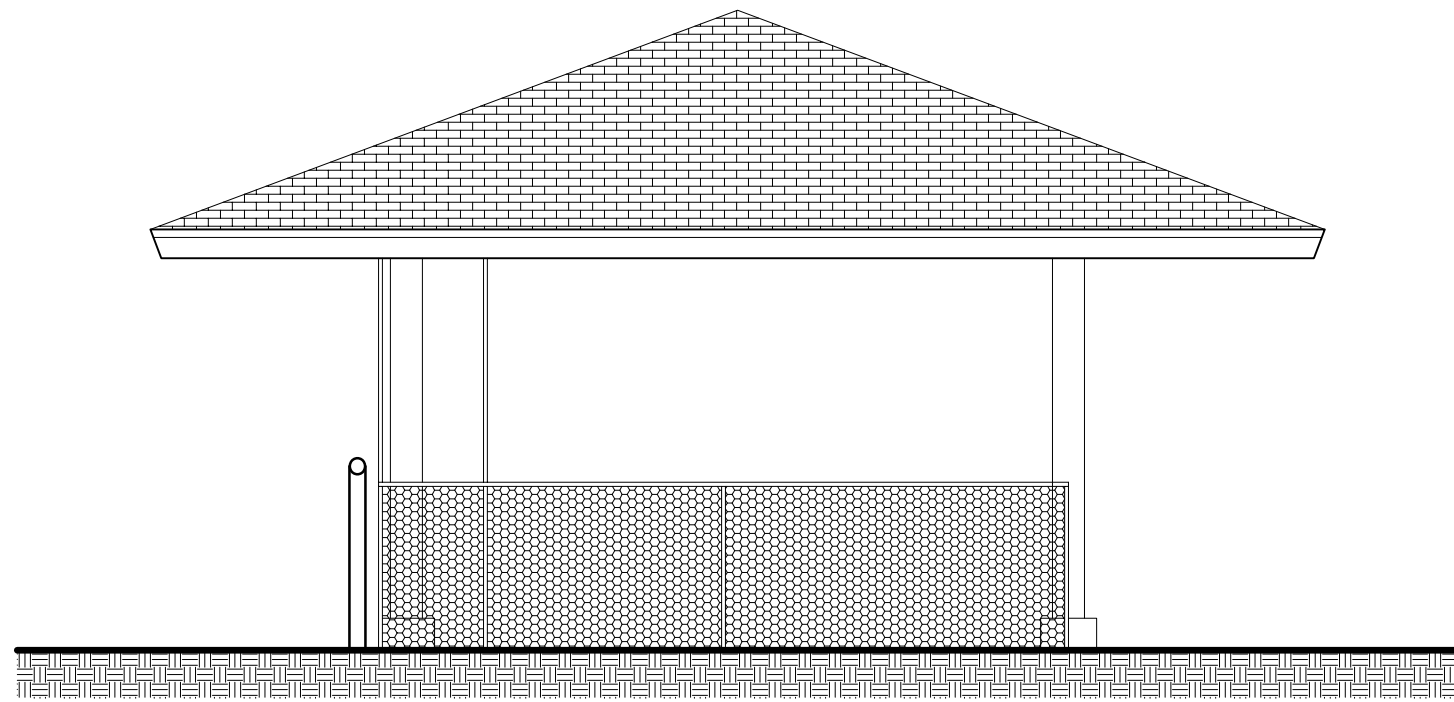

EXTERIOR ELEVATION - PERGOLA - EAST

1/4" = 1'-0"



Architectural
Resources Group

GRIFFITH PARK PONY RIDE

AS-BUILT DRAWINGS
4400 CRYSTAL SPRINGS DRIVE, LOS ANGELES, CA
3/27/2024

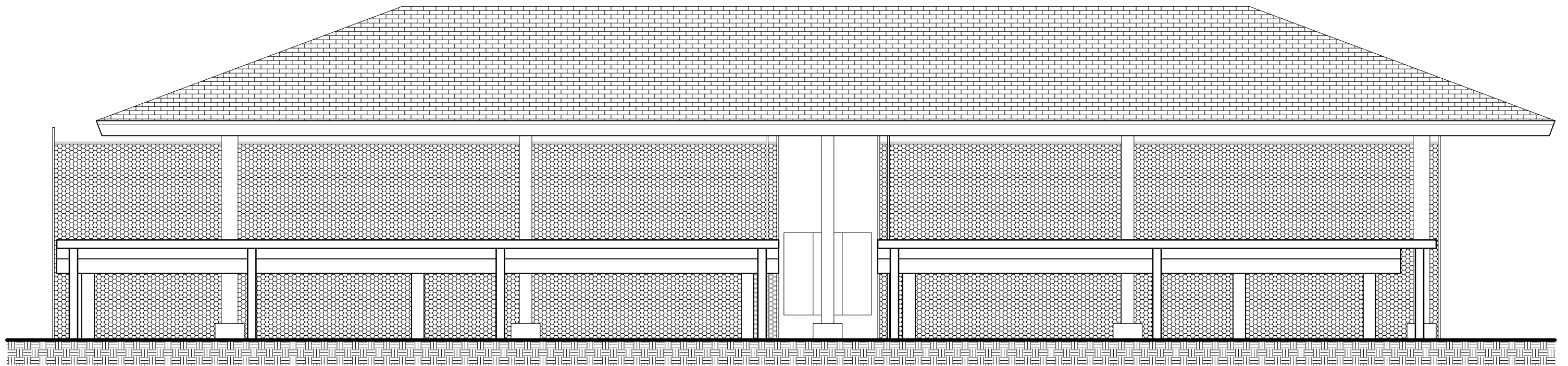

EXTERIOR ELEVATION - PERGOLA - SOUTH

1/4" = 1'-0"



Architectural
Resources Group

GRIFFITH PARK PONY RIDE

AS-BUILT DRAWINGS
4400 CRYSTAL SPRINGS DRIVE, LOS ANGELES, CA
3/27/2024

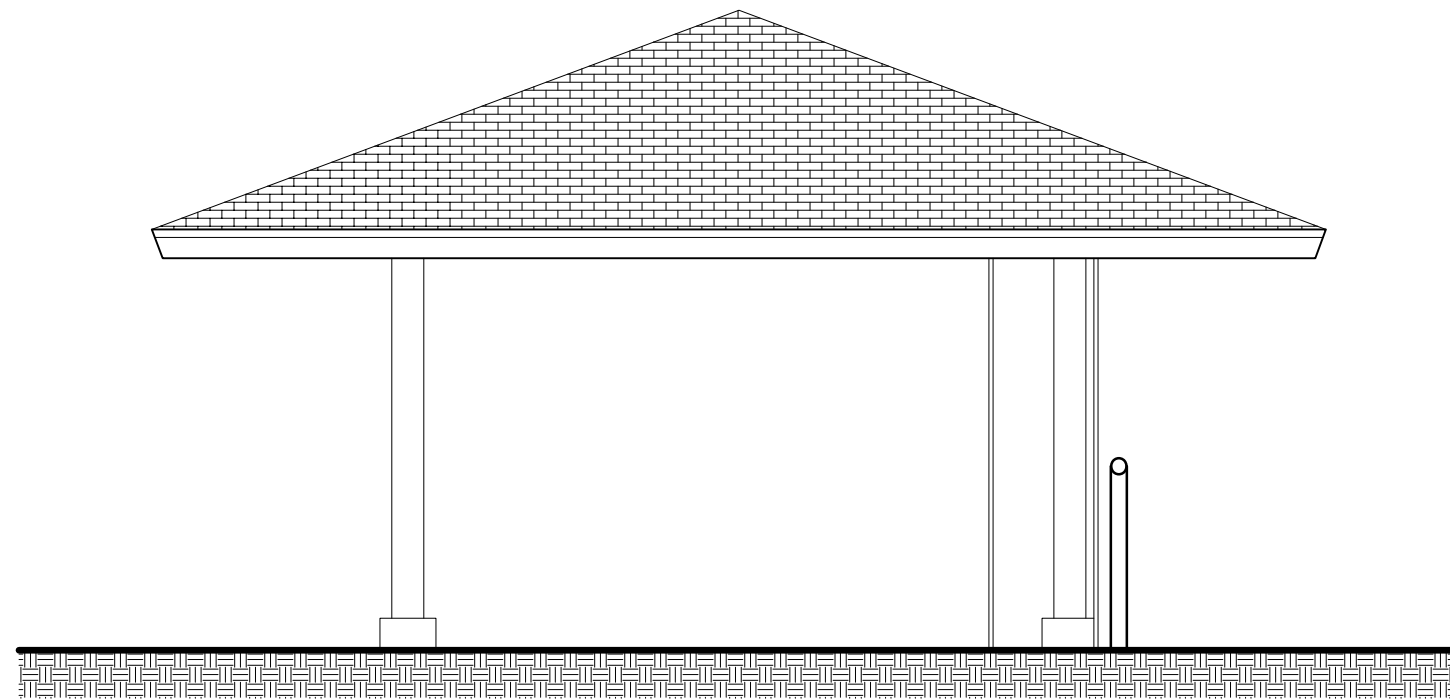

EXTERIOR ELEVATION - PERGOLA - WEST

1/4" = 1'-0"



Architectural
Resources Group

GRIFFITH PARK PONY RIDE

AS-BUILT DRAWINGS
4400 CRYSTAL SPRINGS DRIVE, LOS ANGELES, CA
3/27/2024

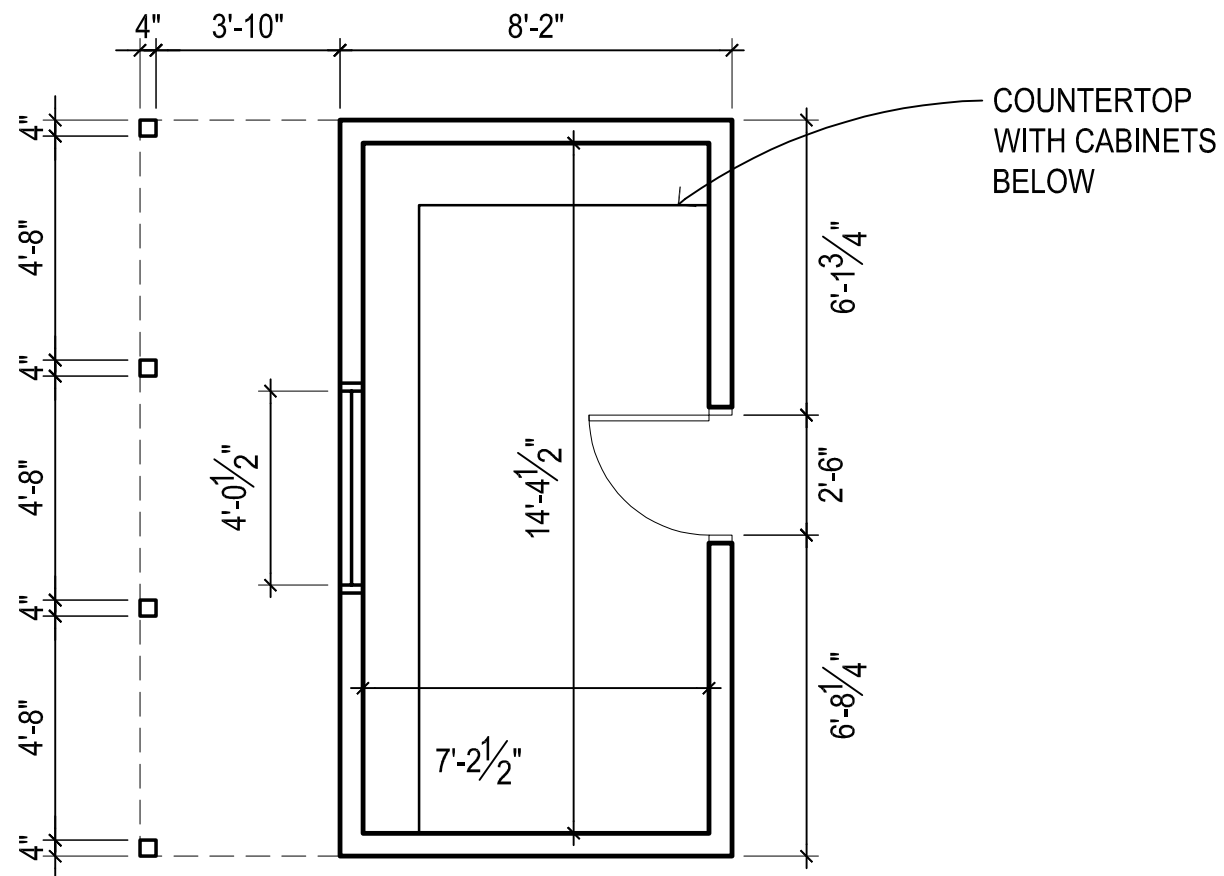

FLOOR PLAN - TICKET BOOTH

1/4" = 1'-0"



Architectural
Resources Group

GRIFFITH PARK PONY RIDE

AS-BUILT DRAWINGS
4400 CRYSTAL SPRINGS DRIVE, LOS ANGELES, CA
3/27/2024

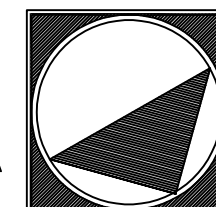

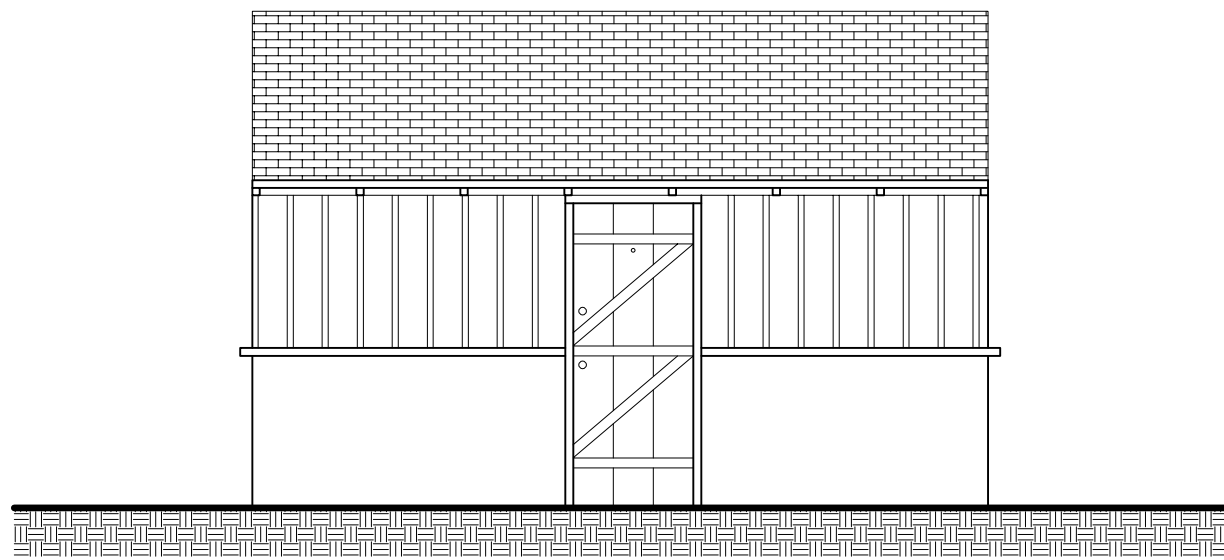

EXTERIOR ELEVATION - TICKET BOOTH - NORTH

1/4" = 1'-0"



Architectural
Resources Group

GRIFFITH PARK PONY RIDE

AS-BUILT DRAWINGS
4400 CRYSTAL SPRINGS DRIVE, LOS ANGELES, CA
3/27/2024

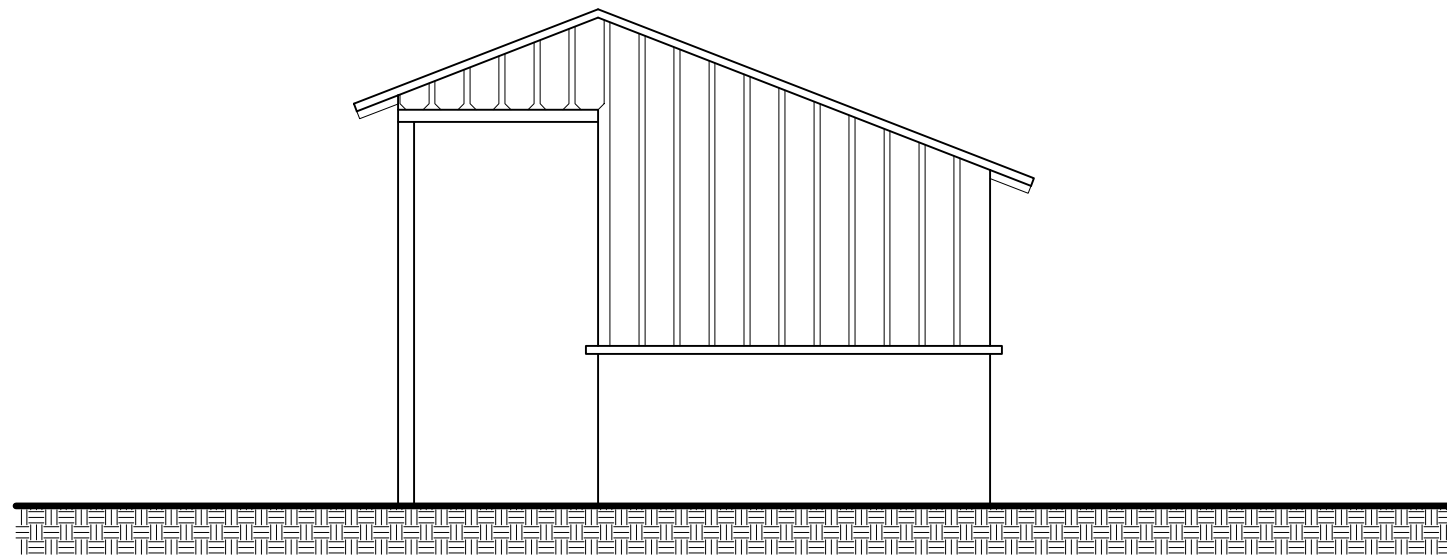

EXTERIOR ELEVATION - TICKET BOOTH - EAST

1/4" = 1'-0"



Architectural
Resources Group

GRIFFITH PARK PONY RIDE

AS-BUILT DRAWINGS
4400 CRYSTAL SPRINGS DRIVE, LOS ANGELES, CA
3/27/2024

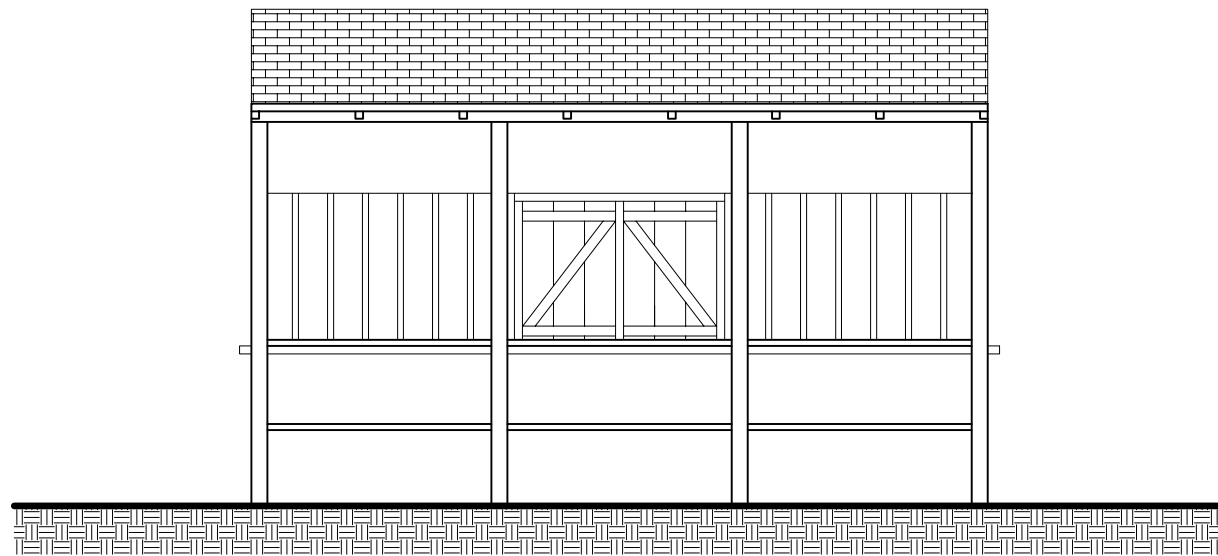

EXTERIOR ELEVATION - TICKET BOOTH - SOUTH

1/4" = 1'-0"



Architectural
Resources Group

GRIFFITH PARK PONY RIDE

AS-BUILT DRAWINGS
4400 CRYSTAL SPRINGS DRIVE, LOS ANGELES, CA
3/27/2024

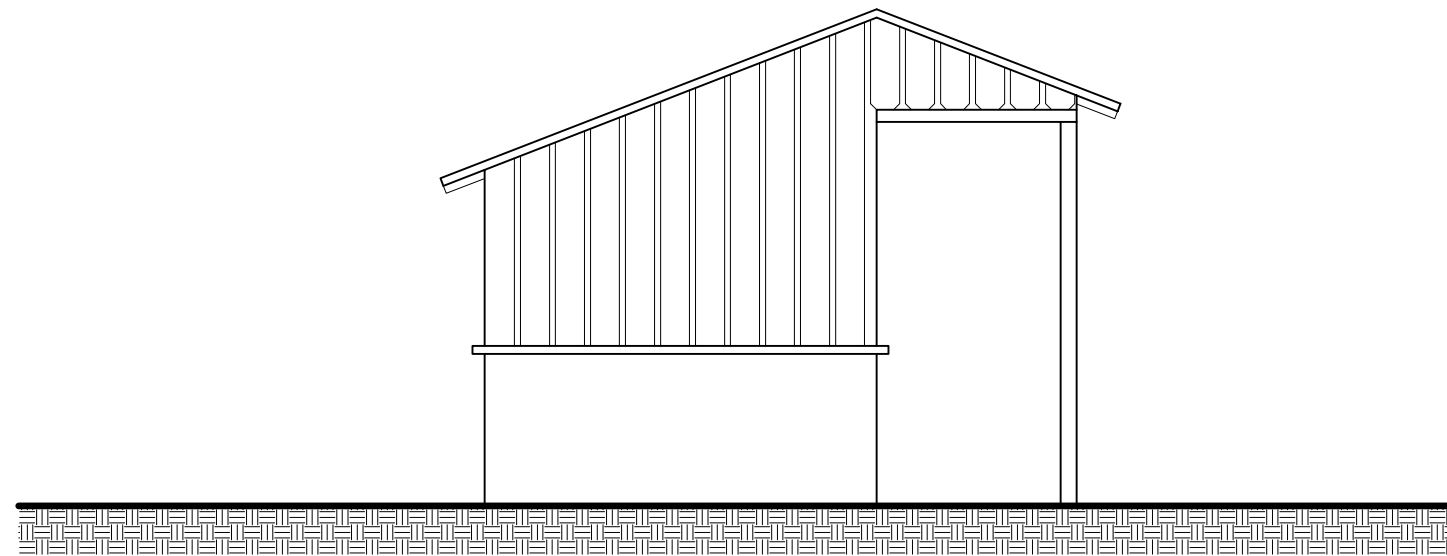

EXTERIOR ELEVATION - TICKET BOOTH - WEST

1/4" = 1'-0"



Architectural
Resources Group

GRIFFITH PARK PONY RIDE

AS-BUILT DRAWINGS
4400 CRYSTAL SPRINGS DRIVE, LOS ANGELES, CA
3/27/2024



SCALE - 1" = 20'
 GRIFFITH PARK - PONY RIDE AREA
 APRIL 14 12 ROCHE
 JAN 14 12 ROCHE

CRYSTAL SPRINGS ROAD

INSTALL 20' CURB CUT
2 FT FROM EXIST. OAK TREE

25'-0"

20'-0"

12'-0"

EXIST. OAK

EXIST. SWALE

REMOVE BROKEN CONCRETE
FILL W. GRAVEL UP TO 2" BELOW
GRADE, COMPACT & COVER W. 2" A.C.
APPROX. 250 SQ. FT.

REPAIR LEAKING VALVES IN WATER BOXES

EXISTING PONY RIDE

AREA TO BE GRADED DOWN
ABOUT 6"

SCOPE OF WORK :

1. REPAIR 2 LEAKING VALVES IN WATER BOXES
2. REMOVE BROKEN CONCRETE IN EXIST. SWALE, FILL WITH GRAVEL TO 2" BELOW EXIST. DRAINAGE GRADE AND PAVE WITH 2" A.C. SLOPE TO DRAIN.
3. BREAK OUT EXISTING MASONRY CURB 20' WIDE WITH 2' OF BREAK 25' SOUTH OF EXISTING OAK TREE AS SHOWN. REMOVE EXCESSIVE DIRT, COMPACT SUBGRADE AND ALLOW FOR 3" OF SURFACING. PAVE APRON WITH 3" THICK A.C. WITH 2"x4" REDWD. HEADERS NAILED TO 1"x4"x18" STAKES 3 1/2' O.C.
4. REMOVE TURF FOR 12' WIDE ROADWAY AS SHOWN. GRADE SUBGRADE TO ELIMINATE HUMPS AND DEPRESSIONS.
5. SPREAD D.G. OVER ROADWAY SURFACE 12' WIDE TO A MIN. THICKNESS OF 4". ROLL FOR COMPACTION WITH HEAVY ROLLER. FINISH SURFACE SHALL BE ONE INCH ABOVE ADJACENT LAWN GRADES.

SCALE 1" = 20'

000017

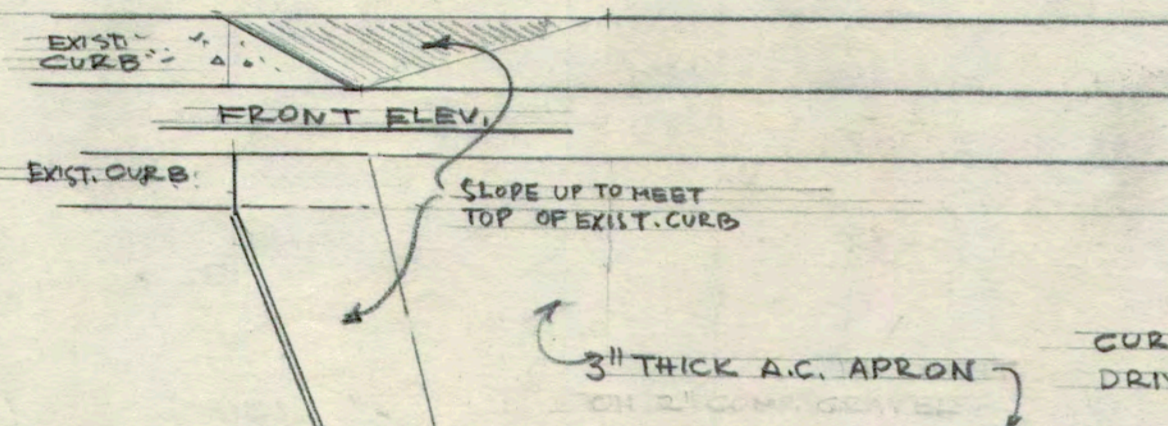
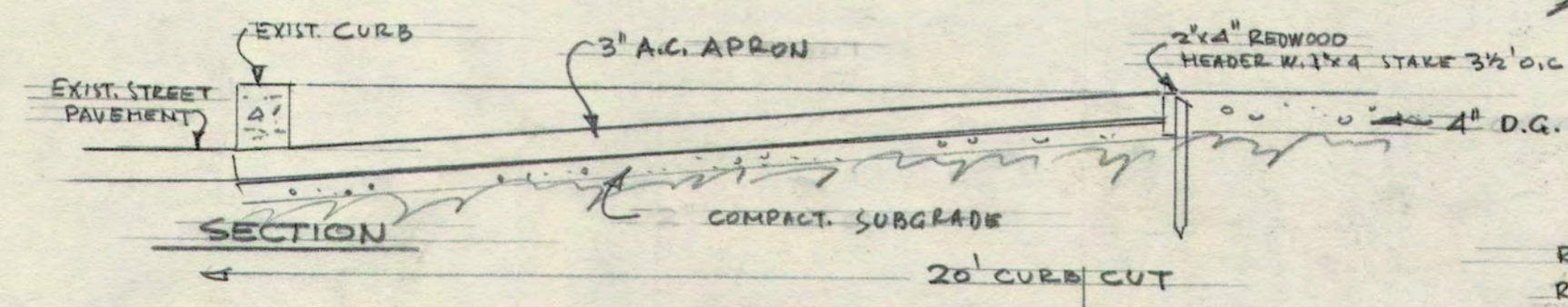

CURB CUT DETAIL SCALE 1/2" = 1'-0"

PLAN

2"x4" REDWOOD HEADER NAILED TO 1"x4" STAKES 3 1/2' O.C.

ROAD ROAD WIDTH 12' 4" D.G.

CORRALS

STABLES

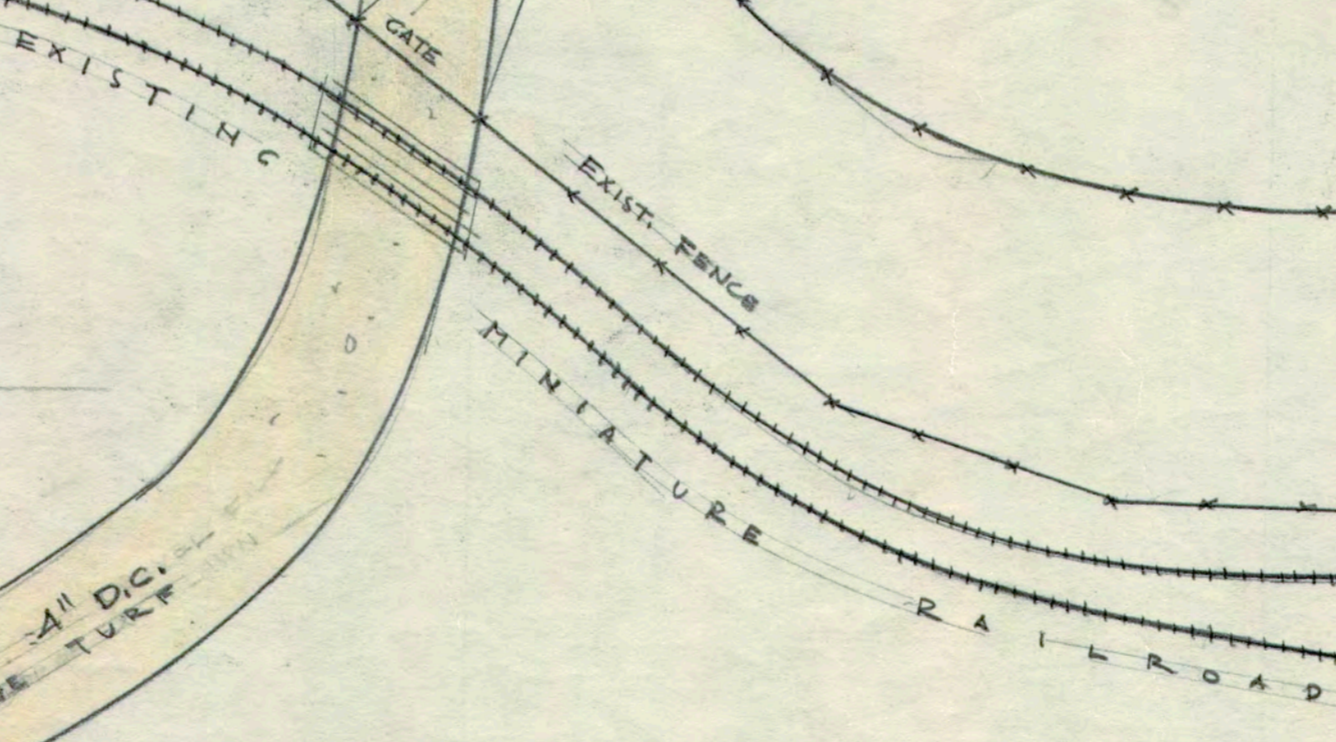

APPROVALS		DATE	
ROADWAY TO PONY STABLES			
PONY RIDE AREA			
GRIFFITH PARK			
DEPARTMENT OF RECREATION AND PARKS			
PLANNING & ENGINEERING DIVISION			
CITY OF LOS ANGELES, CALIFORNIA			
SUIT. OF PARK DEV.		DESIGNED BY	A.P.
SUIT. OF REC.		DRAWN BY	A.P.
SUIT. OF ADM.		CHECKED BY	
GENERAL MANAGER		FILE NO.	335
REFERENCES	JOB NO.	97	SHEET
SUBMITTED BY	DATE	SEP. 1957	1
PLANNING & ENGINEERING DIV.	OF ONE		

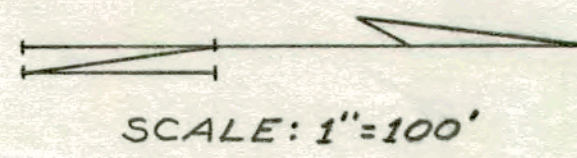
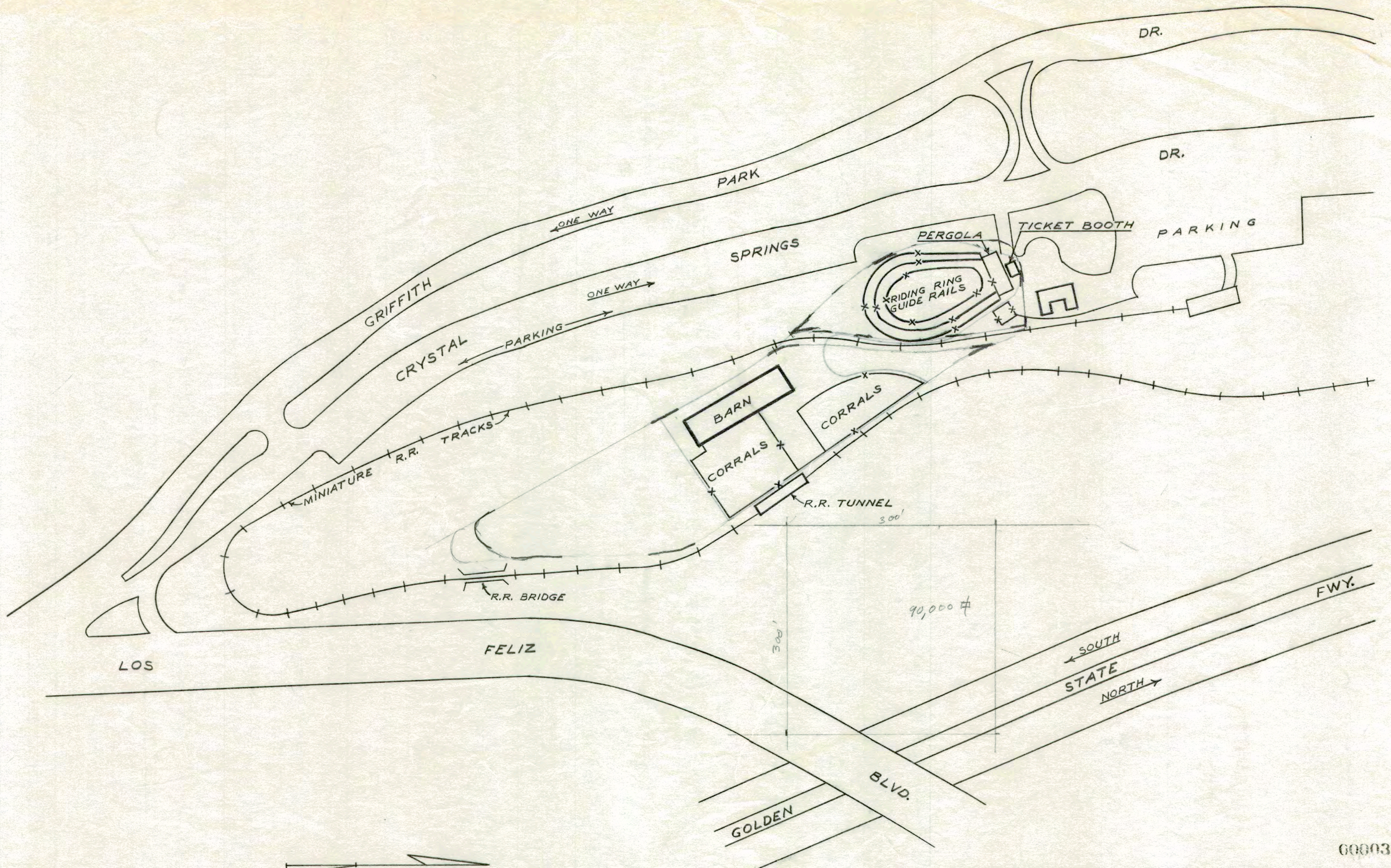

000033

SHEET TITLE					EXHIBIT "D"									
PROJECT										SITE PLAN - GRIFFITH PARK PONY RIDE				
FACILITY - ADDRESS										CRYSTAL SPRINGS DR. - GRIFFITH PARK				
SUPT. OF PARKS		REVISION		DATE		BY		DESIGNED BY:		DRAWN BY: RG				
SUPT. OF RECREATION										CHECKED BY: TW				
SUPT. OF PLANNING AND DEVELOPMENT										SUBMITTED BY: TW				
GENERAL MANAGER										DATE: SEPT, '77				
										FILE NO.		373		
CITY OF LOS ANGELES										DEPARTMENT OF RECREATION AND PARKS		SHEET 1		
200 N. MAIN STREET, CITY HALL EAST, LOS ANGELES, CALIFORNIA, 90012										OF 1 SHEETS				

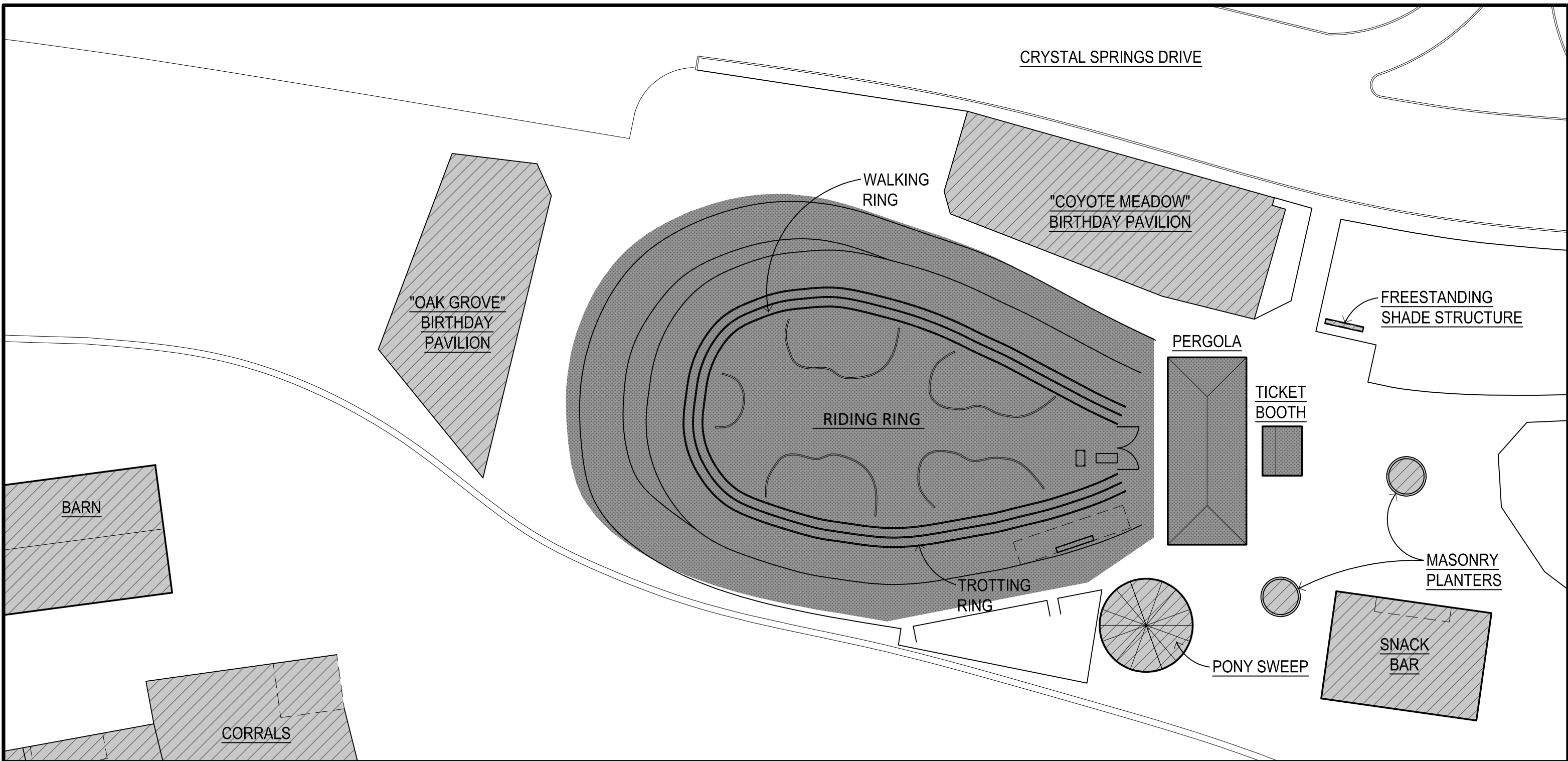

NOTE: CONTRACTORS SHALL VERIFY ALL DIMENSIONS AND BE RESPONSIBLE FOR SAME.



SITE PLAN - CONTRIBUTING AND NON-CONTRIBUTING BUILDINGS, STRUCTURES, AND SMALL-SCALE FEATURES

1" = 30'-0"

LEGEND

-  CONTRIBUTING
-  NON-CONTRIBUTING



Architectural Resources Group

GRIFFITH PARK PONY RIDE

AS-BUILT DRAWINGS
 4400 CRYSTAL SPRINGS DRIVE, LOS ANGELES, CA
 03/27/2024

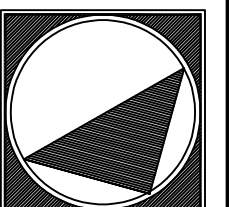

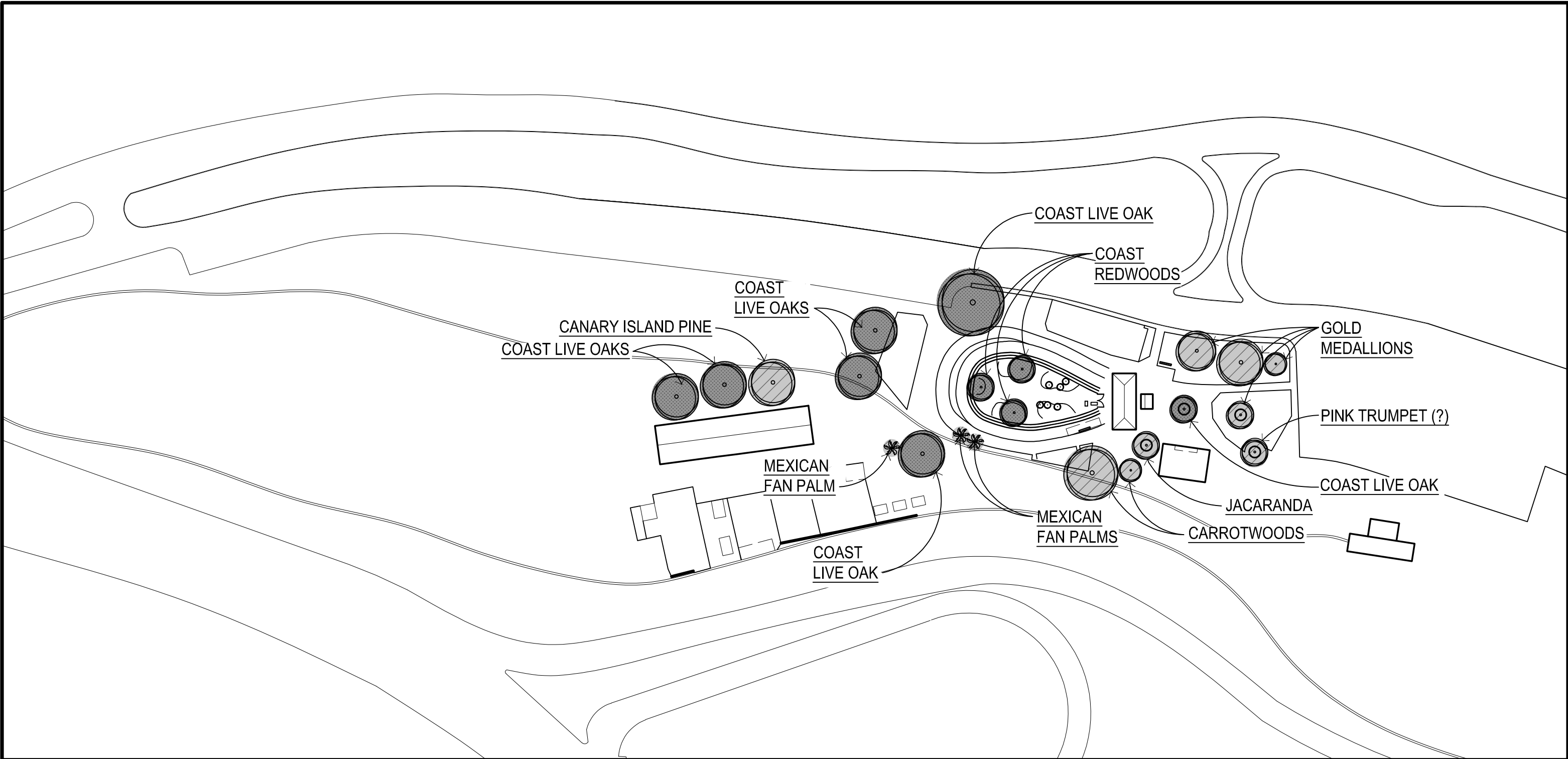



SITE PLAN - CONTRIBUTING AND NON-CONTRIBUTING VEGETATION

1" = 100'-0"

LEGEND

-  CONTRIBUTING
-  NON-CONTRIBUTING

GRIFFITH PARK PONY RIDE

AS-BUILT DRAWINGS
 4400 CRYSTAL SPRINGS DRIVE, LOS ANGELES, CA
 03/27/2024



Architectural
Resources Group

